

Model VH-50 Ventless Hood/Oven Combo

Ventless Exhaust Hood System with Two Deck Electric Oven

HOOD FEATURES

- **Certified Ventless**
UL Certified Ventless under 710B
- **Stainless Steel**, Durable and polished 18-gauge
- **Convenient**
Easily vent grease-laden vapors
- **Self-contained, compact**
Eliminates need for ductwork or roof fans
- **Meets food service requirements**
Triple filter system with updraft technology designed to trap grease particles, eliminate condensation, and reduce cooking odors
- **Safe**
Optional built-in Ansul R-102 wet chemical fire suppression system (field installation must be performed by an ANSUL distributor)
- **Alert System**
Color coded, lighted alerts to ensure system is running safely and efficiently
- **Interlocking Start Safety Feature**
Does not allow hood and oven to work separately

OVEN FEATURES

- **Certified** by Intertek's Electrical Testing Labs
- **Stainless Steel Front**, Standard
- **Large Capacity**
2,688 sq. inches of available cooking space.
- **Pizza Decks**, Standard
Large 42"x32"x7" compartment with 1" pizza stones
- **Unique Interior Design**
Better distribution of heat
- **Energy Efficient**
Energy-saving tubular elements coupled with our unique baffle system for even heat and better baking
- **Full Range Digital Thermostat**
300°F - 650°F (149°C - 343°C) Precise temperature control
- **Solid State Relay** for silent operation
- **Power, Electric**
Single phase standard; Three phase optional

WARRANTY

- One year limited manufacturer's warranty



SHOWN
VH-50 Ventless Hood/Oven Combo

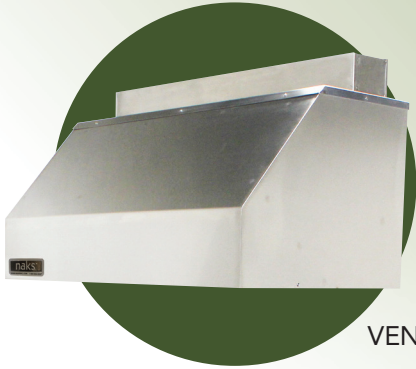

VENTLESS HOOD



TWO DECK
ELECTRIC OVEN



TWO DECK
ELECTRIC OVEN
DOORS OPEN

MODEL VH-50 VENTLESS COMBO

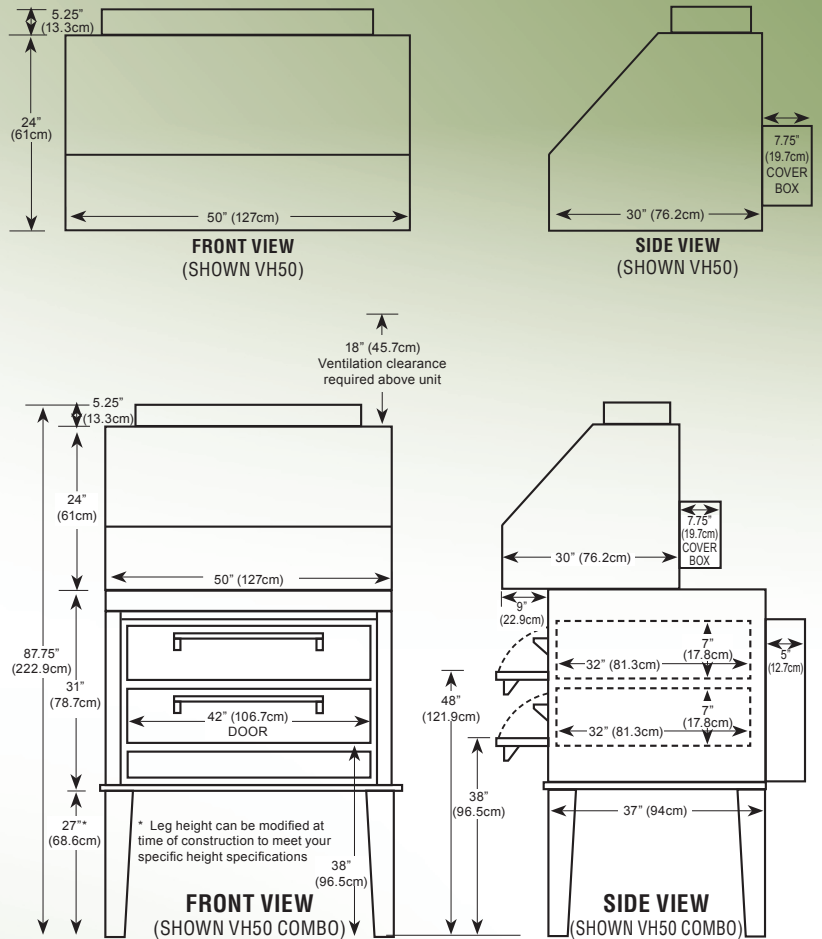

VENTLESS HOOD

Dimensions 50" (127cm) wide x 37.75" (95.9cm) deep x 29.25" (74.3cm) high
 Ventilation Clearance 18" (45.7cm) from top of unit, not including damper
 Pull Station Clearance 30" (76.2cm)
 Shipping weight 325 lbs (147.4kg)
 Voltage 208/240 V AC, single or three phase

TWO DECK ELECTRIC OVEN

Floor space 50" (127cm) wide x 42" (106.7cm) deep* x 58" (147.3cm) high
 Opening required for installation: 32" * Handle adds 2.5"(6.4cm) to depth
 Shelf size 42" (106.7cm) wide x 32" (81.3cm) deep x 7" (17.8cm) high
 Shipping weight 850 lbs (385.6kg)
 Capacity Twelve 12" (30.5cm) pizzas or eight 16" (40.7cm) pizzas
 Electric 12KW - 220V single phase, 60 AMPS
 Optional three phase, 40 AMPS

Important Ventless Information:

- Clearance – Ventless clearance requirement above unit 18"
- 30" clearance at pull station.
(Pull station located on left can be requested on right)

172 REASER CT.
 ELYRIA, OH 44035
 TELEPHONE: 1.440.365.4567
 EMAIL: SALES@NAKSINC.COM