

Gas-Fired Tempered Make-Up Air Unit

Model:

TK1DD-1PH-FF

1-Phase, 208V, 1.00 HP, Direct Drive, Premium (E-Plus) Eff. Motor with Motorized Damper and 15" Blower. MAX 1200 CFM's



TK1-250-15D Direct Fired Direct Drive (638 lbs.)



Direct Gas Fired Heated Make Up Air Unit with 15" Direct Drive Fan

Supply Motor:

Model DTP0014, 1.000 HP, 3 Phase, 208 V, 60Hz, 3.1 FLA, ODP, Premium (E-Plus3) Eff.

Burner:

Min Output BTU: 18,000 BTU/Hr
Max Output BTU: 275,000 BTU/Hr
Size: 6" long
Gas Type: Natural

Supply Performance:

Volume Range: 1000-1200 cfm
RPM: 1493
TS: 5863 ft/min
SP: 0.527" w.g.
0.500" Ext. + 0.016" Int. + 0.011" Opt.
BHP: 0.483

Heating Schedule:

Altitude: 0'
Winter Entering Air Dry Bulb Temp: 0°F
Temp Rise: 100°F
Output BTU: 129600
Input BTU: 140870
BTUs BASED OFF STANDARD AIR DENSITY

Supply Installation Information:

Gas Inlet Pressure: 7 in. w.c. - 14 in. w.c.
Insurance: No Insurance Requirement (ANSI)
Unit Main Input: 5.1 Amps MCA, 15 Amps MOP, 208 V, 14 AWG Wire Min.
Supply Unit Voltage: 3 phs 208 V 60Hz

Construction Features

Housing constructed of heavy duty G90 galvanized steel • Vibration isolation • Ball bearing motors • Heavy duty, pre-lubricated bearings rated for 200,000 hours of operation • Service doors on both sides • Horizontal & down discharge • Large intake area ensures low pressure drop across unit • Spring loaded profile plates automatically adjust for any airflow - no manual setting required! • Weatherproof safety disconnect switch • Modular design provides design flexibility • Fully insulated casing

Blower:

15 Inch Mixed Flow Plenum Fan for size 1 MOD. Hub specified to match motor shaft.

Temp Control:

RTC Solutions • 40-90°F Discharge Temp Control • Field Wired On/Off Start Command

Intake:

Sloped Filtered Intake for Size #1 Modular Heater. 21.813" Wide x 44.375" Long x 23.375" High. Includes 2" MV EZ Kleen Metal Mesh Filters.

Filters:

3x MV EZ Kleen Metal Mesh Filter. 16"x 20"x 2" Used for heater and supply fan intakes. (3412)

Selected Options:

- Motorized Back Draft Damper 16" X 18" for Size 1 Standard & Modular Heater Units w/Extended Shaft, Standard Galvanized Construction, 3/4" Rear Flange, Low Leakage, TFB120S Actuator Included
- Low Fire Start. Allows the burner circuit to energize when the modulation control is in a low fire position.
- Gas Pressure Gauge, 0-35", 2.5" Diameter, 1/4" Thread Size
- Gas Pressure Gauge, -5 to +15 Inches Wc., 2.5" Diameter, 1/4" Thread Size
- VAV (Variable-Air-Volume) Wiring Package for Commercial Fans. Manual Speed Control Variable Frequency Drive Included
- Supply Variable Frequency Drive - 1 HP Max., 200/240 V, Single or Three Phase Input, 4.2 A Max., NEMA 1 Enclosure, (Default Shipped Loose for Field Installation) PART NEEDS PROGRAMMING
- VFD factory mounted and wired on unit control panel.

TK1-250-15D DIRECT FIRED HEATER

1. DIRECT GAS FIRED HEATED MAKE UP AIR UNIT WITH 15' DIRECT DRIVE FAN
2. INTAKE HOOD WITH EZ FILTERS
3. DOWN DISCHARGE - AIR FLOW RIGHT -> LEFT
4. MOTORIZED BACK DRAFT DAMPER 16" X 18" FOR SIZE 1 STANDARD & MODULAR HEATER UNITS W/EXTENDED SHAFT, STANDARD GALVANIZED CONSTRUCTION, 3/4" REAR FLANGE, LOW LEAKAGE, TFB120S ACTUATOR INCLUDED
5. LOW FIRE START, ALLOWS THE BURNER CIRCUIT TO ENERGIZE WHEN THE MODULATION CONTROL IS IN A LOW FIRE POSITION.
6. GAS PRESSURE GAUGE, 0-35", 2.5" DIAMETER, 1/4" THREAD SIZE
7. GAS PRESSURE GAUGE, -5 TO +15 INCHES WC., 2.5" DIAMETER, 1/4" THREAD SIZE
8. VAV (VARIABLE-AIR-VOLUME) WIRING PACKAGE FOR COMMERCIAL FANS.
- MANUAL SPEED CONTROL VARIABLE FREQUENCY DRIVE INCLUDED
9. VFD FACTORY MOUNTED AND WIRED ON UNIT CONTROL PANEL.

NOTE: SUPPLY DUCT MUST BE INSTALLED TO MEET SMACNA STANDARDS. A MINIMUM STRAIGHT DUCT LENGTH MUST BE MAINTAINED DOWNSTREAM OF UNIT DISCHARGE UNLESS OTHERWISE SPECIFIED. DO NOT RELY ON UNIT TO SUPPORT DUCT IN ANY WAY. FAILURE TO PROPERLY SIZE DUCTWORK MAY CAUSE SYSTEM EFFECTS AND REDUCE PERFORMANCE OF THE EQUIPMENT.

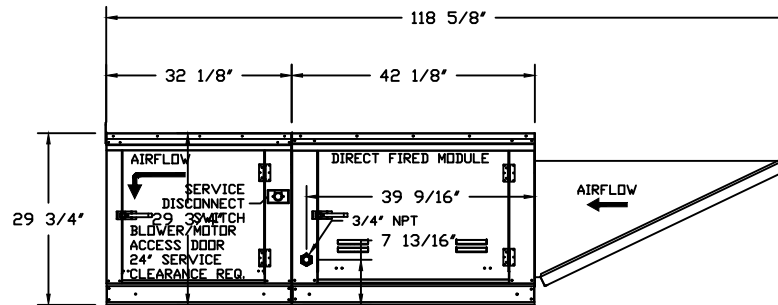
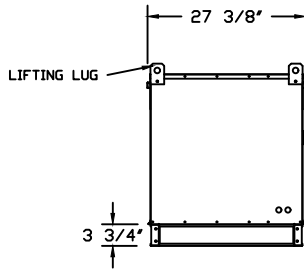
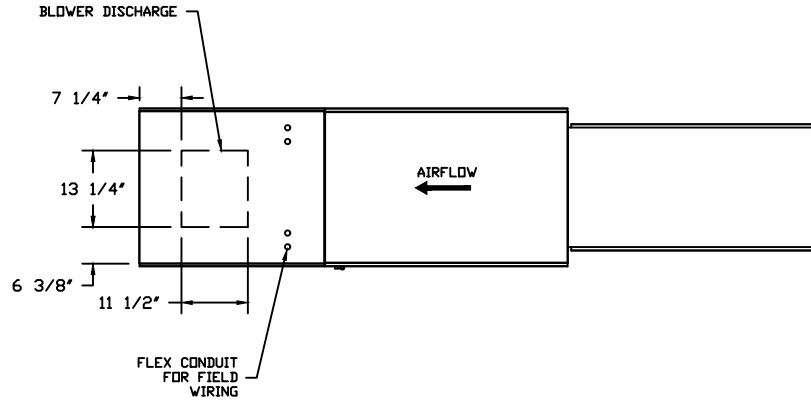

| | |
|----------------|--------------------|
| JOB | |
| LOCATION | |
| DATE 2/22/2019 | JOB # |
| DWG # | DRAWN BY |
| REV. | SCALE 3/8" = 1'-0" |

(1200 1HP/3PH-208V) - HEATER PERFORMANCE CURVES.

1200 CFM, 0.527 SP @ 1493 RPM and 0.483 BHP at 0 feet and 100 deg F
 * Please note that these curves were adjusted for job specific temperature and altitude.

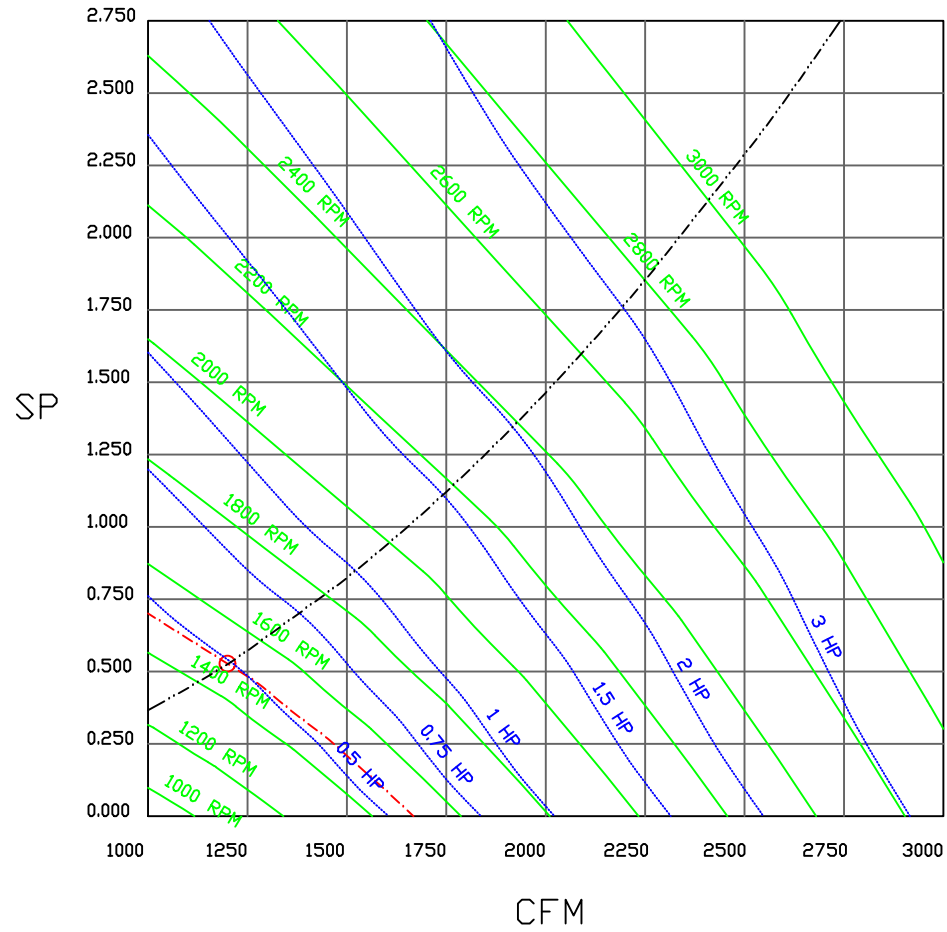

| | |
|----------|--------------------|
| JOB | |
| LOCATION | |
| DATE | JOB # |
| DWG # | DRAWN BY |
| REV. | SCALE 3/8" = 1'-0" |

VFD Wiring

JOB NAKS Direct Fired Direct Drive MUA

DRAWING NUMBER

SHIP DATE

MODEL TK 1-5 Series Direct Drive

SMV SERIES VARIABLE FREQUENCY DRIVE

Installed Options
Manual Control

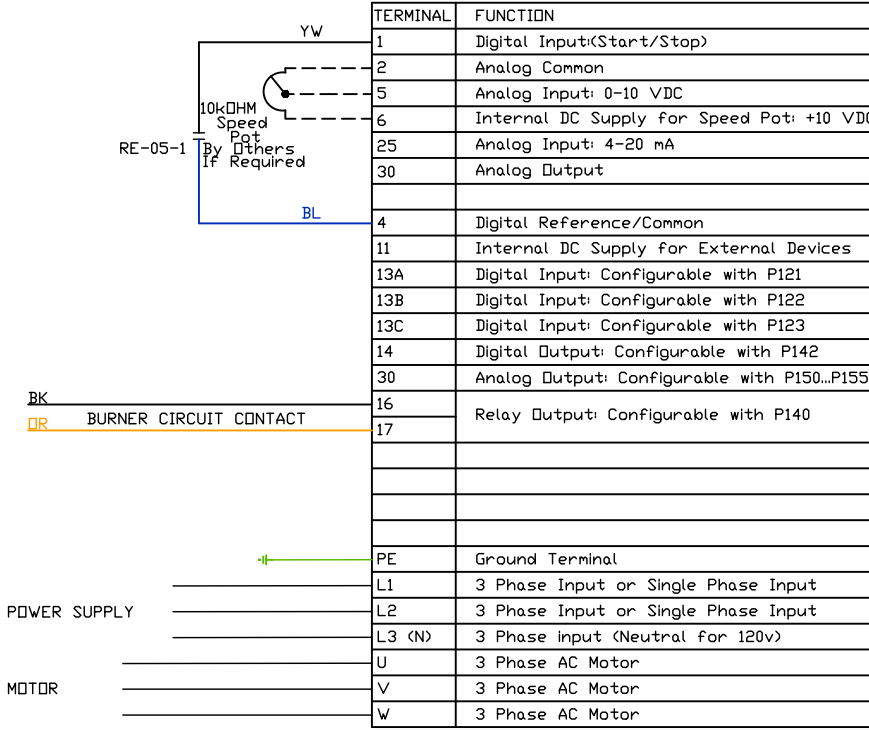

| TERMINAL | FUNCTION |
|----------|--|
| 1 | Digital Input(Start/Stop) |
| 2 | Analog Common |
| 5 | Analog Input: 0-10 VDC |
| 6 | Internal DC Supply for Speed Pot: +10 VDC |
| 25 | Analog Input: 4-20 mA |
| 30 | Analog Output |
| 4 | Digital Reference/Common |
| 11 | Internal DC Supply for External Devices |
| 13A | Digital Input: Configurable with P121 |
| 13B | Digital Input: Configurable with P122 |
| 13C | Digital Input: Configurable with P123 |
| 14 | Digital Output: Configurable with P142 |
| 30 | Analog Output: Configurable with P150...P155 |
| 16 | Relay Output: Configurable with P140 |
| 17 | Relay Output: Configurable with P140 |
| PE | Ground Terminal |
| L1 | 3 Phase Input or Single Phase Input |
| L2 | 3 Phase Input or Single Phase Input |
| L3 (N) | 3 Phase input (Neutral for 120v) |
| U | 3 Phase AC Motor |
| V | 3 Phase AC Motor |
| W | 3 Phase AC Motor |

Component Identification

RE-05 VFD Start relay [2]

SUPPLY DRIVE PARAMETER SETTINGS*

All external control wires to motor speed control should be 16-20 AWG shielded multiconductor cables and must not be run in the same conduit or raceway with any high power wiring. Ground Shielded Cable at the drive chassis ONLY.

PG. 11 OF THE DRIVE MANUAL DESCRIBES THE PROPER INSTALLATION PROCEDURE

PG. 19 OF THE DRIVE MANUAL DESCRIBES THE PROGRAMMING PROCEDURE OF THE DRIVE

PG. 23 OF THE DRIVE MANUAL DESCRIBES THE PARAMETER SETTINGS OF THE DRIVE

*NOTE: THE DEFAULT PASSWORD FROM THE FACTORY REQUIRED TO PROGRAM THE DRIVE IS '225'.

EPM PROGRAM: VAV_MANKUSE LG_HP EPM IF >= 15HP)
 P100 (Start Source) = 01 (Terminal Strip)
 P102 = ##Minimum Frequency (Hz)
 P103 = ##Maximum Frequency (Hz)
 (P103 is based on max wheel RPM)
 P110 (Start Method) = 03 (Auto Re-start)
 P140 (Form A (NO) Relay) = 01 (Run)
 P144 (Relay Inversion) = 00 (None)
 P166 (Carrier Frequency) = 00 (4 kHz)
 P171 (Current Limit) = 150 (% of Max I)

Adjust manually on all drives
 P107 - 00 (If 120 or 208 VAC)
 or 01 (If 230, 480 or 575 VAC)
 P108 - Motor FLA x 100 / Drive Output Rating
 P165 (Base Voltage) = Set to Motor Voltage
 (Preset@230V) P165 FDR STANDARD DRIVE ONLY
 P167 (Base Frequency) = Calculated Per Fan
 FDR KB PCU ONLY: P300 = 0

When Speed POT is Required the Following Parameters Must be Set:
 P101 (Reference Source) = 01 (0-10 VDC)
 P160 (Speed @ 0 VDC Signal) = Min Frequency
 P161 (Speed @ 10 VDC Signal) = Max Frequency

IT MAY BE REQUIRED TO FULLY POWER DOWN THE DRIVE AND TURN BACK ON IN ORDER TO INITIATE NEW PARAMETER SETTINGS.

##Min. and Max. Frequency Settings override all other Preset speeds/Parameters.

MOTOR INFO
 SUPPLY 1HP-208V-3P-3.1FLA
 VFD PART: ESV751N02YXB

ELECTRICAL INFORMATION
 MOTOR/CTRL CIRCUIT MCA: 51A
 MOTOR/CTRL CIRCUIT MDP: 15A

NOTES

----- DENOTES FIELD WIRING
 _____ DENOTES INTERNAL WIRING

WIRE COLOR

BK - BLACK YW - YELLOW
 BL - BLUE GR - GREEN
 BR - BRDWN GY - GRAY
 OR - ORANGE PR - PURPLE
 RD - RED PK - PINK
 WH - WHITE

GENERAL NOTES

1
2
3
4
5
6
7
8
9
10
11
12
13
14
15
16
17
18
19
20
21
22
23

Direct Fired Heater Wiring

JOB NAKS Direct Fired Direct Drive MUA

DRAWING NUMBER

SHIP DATE

MODEL TK 1-5 Series Direct Drive

ATTENTION ELECTRICIAN!
 DROP FDR DISCONNECT CONNECTION
 IS FACTORY SUPPLIED
 CONNECT POWER TO THE DROP

Installed Options
 Field Wired Single Switch Control
 Motorized Back Draft Damper

Discharge Temp. Control

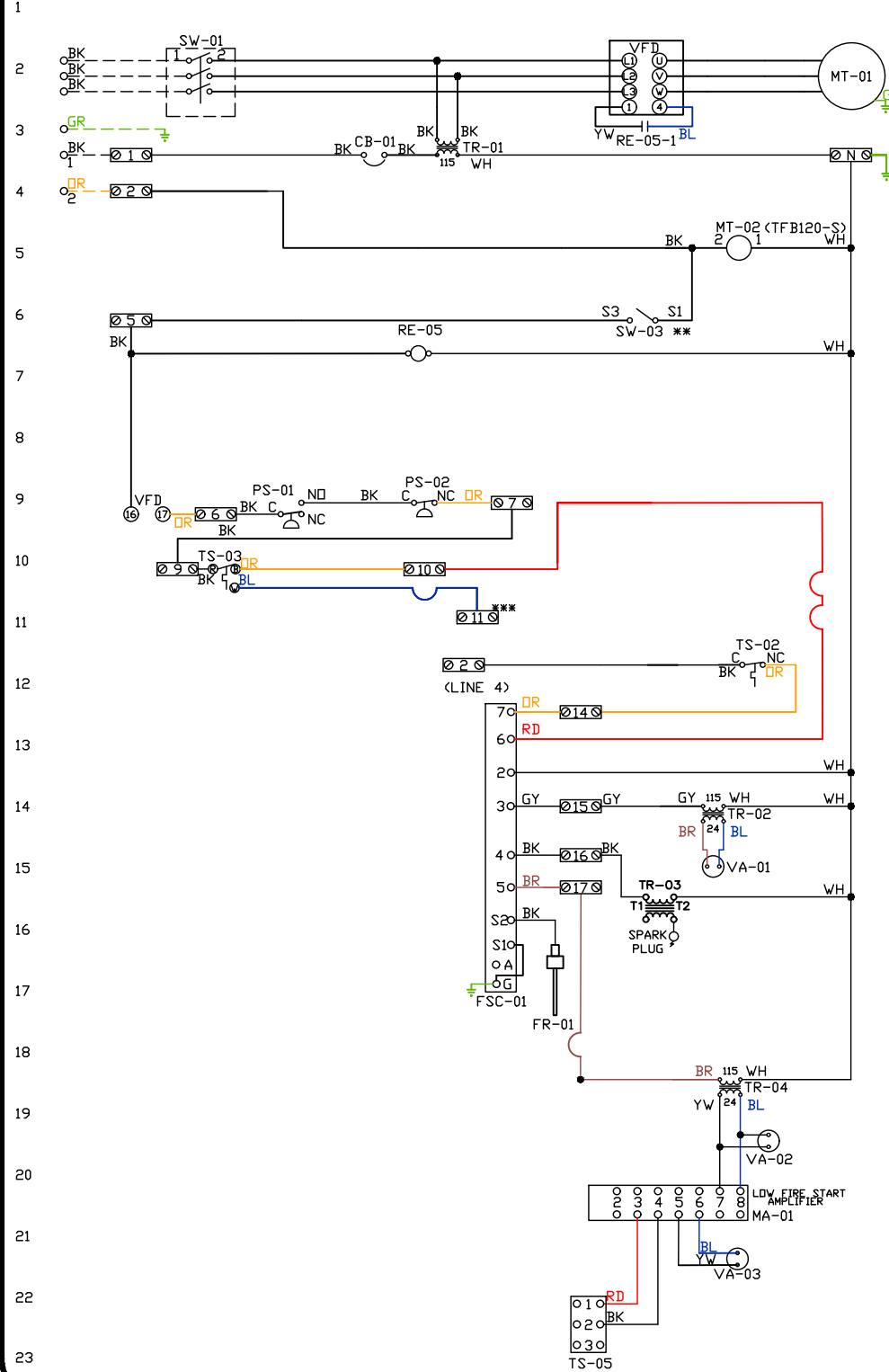

| Label | Component Identification Description | Location |
|--------|--------------------------------------|----------|
| CB-01 | Circuit breaker (2amp) | [3] |
| FR-01 | Flame rod | [16] |
| FSC-01 | Fireeye FSC | [11-14] |
| MA-01 | Modulating amplifier | [19] |
| MT-01 | Supply motor | [2] |
| MT-02 | Damper motor | [5] |
| PS-01 | Low AirFlow Switch | [9] |
| PS-02 | High AirFlow Switch | [9] |
| RE-05 | VFD Start Relay | [3][6] |
| SW-01 | Main disconnect switch | [2] |
| SW-03 | Damper end limit switch | [4] |
| TR-01 | Power transformer(200va) | [12] |
| TR-02 | Power transformer(20va) | [12] |
| TR-03 | Ignition transformer | [14] |
| TR-04 | Power transformer(20va) | [17] |
| TS-02 | High temp limit switch | [10] |
| TS-03 | Intake Air Sensor | [10] |
| TS-05 | Discharge Air Sensor | [21] |
| VA-01 | Pilot gas valve | [13] |
| VA-02 | Main gas valve | [18] |
| VA-03 | Modulating gas valve | [20] |

MOTOR INFO
 SUPPLY 1HP-208V-3P-3.1FLA
 VFD PART: ESV751N02YXB

ELECTRICAL INFORMATION
 MOTOR/CTRL CIRCUIT MCB: 5JA
 MOTOR/CTRL CIRCUIT MDP: 15A

NOTES
 - - - - DENOTES FIELD WIRING
 _____ DENOTES INTERNAL WIRING

** TERMINALS S4 AND S6 USED ON NF & AF SERIES ACTUATORS
 *** TERMINAL 11 PROVIDES COOLING CONNECTION

| WIRE COLOR | SOCKET STYLE |
|-------------|--------------|
| BK - BLACK | NO 4 1 3 |
| BL - BLUE | NC 2 1 |
| BR - BROWN | COM 8 7 |
| GY - GRAY | COM 6 5 |
| RD - RED | |
| WH - WHITE | |
| PK - PINK | |
| PR - PURPLE | |

Installation Wiring

JOB *NAKS Direct Fired MUA*

DRAWING NUMBER

SHIP DATE

MODEL **TK 1-5 Series**

Installed Options



Field Wired On/Off Switch

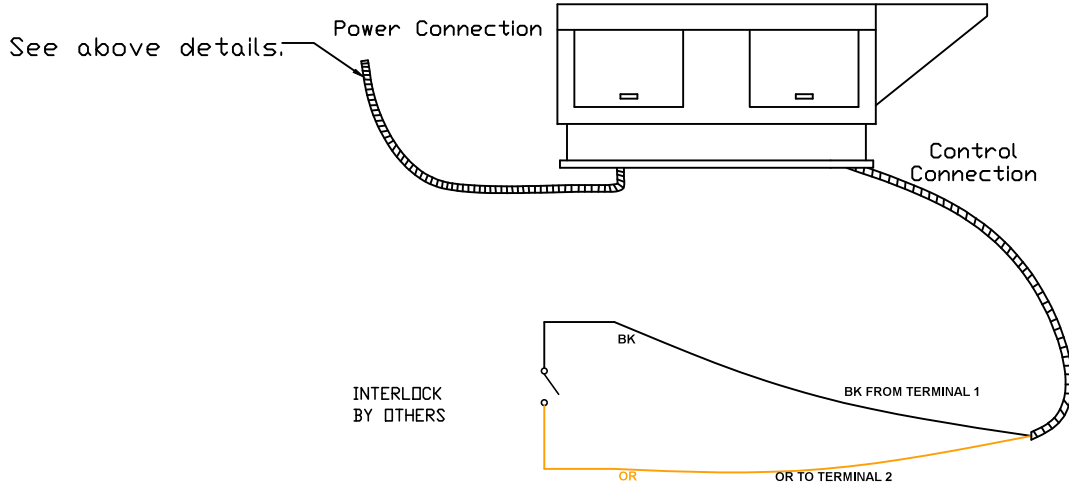

NOTES

- WIRE COLOR**
- BK - BLACK
 - BL - BLUE
 - BR - BROWN
 - OR - ORANGE
 - RD - RED
 - WH - WHITE
 - YW - YELLOW
 - GR - GREEN
 - GY - GRAY
 - PR - PURPLE
 - PK - PINK