

## Gas-Fired Tempered Make-Up Air Unit

Model:

TK3DD-3PH-FF

3-Phase, 208V, 10.0 HP, Direct Drive, Premium (E-Plus) Eff. Motor with Motorized Damper and 24" Blower. MAX 7200 CFM's.



TK3-750-24D Direct Fired Direct Drive (1101 lbs.)



Direct Gas Fired Heated Make Up Air Unit with 24" Direct Drive Fan and 18" Burner.

**Supply Motor:**

Model DTP0104, 10,000 HP, 3 Phase, 208 V, 60Hz, 27.0 FLA, ODP, Premium (E-Plus3) Eff.

**Burner:**

Min Output BTU: 27,500 BTU/Hr  
Max Output BTU: 825,000 BTU/Hr  
Size: 18" long  
Gas Type: Natural

**Supply Performance:**

Volume Range: 3500-7200 cfm  
RPM: 1669  
TS: 10487 ft/min  
SP: 0.687" w.g.  
0.500" Ext. + 0.146" Int. + 0.041" Opt.  
BHP: 8.949

**Heating Schedule:**

Altitude: 0'  
Winter Entering Air Dry Bulb Temp: 0°F  
Temp Rise: 100°F  
Output BTU: 777600  
Input BTU: 845217  
BTUs BASED OFF STANDARD AIR DENSITY

**Supply Installation Information:**

Gas Inlet Pressure: 7 in. w.c. - 14 in. w.c.  
Insurance: No Insurance Requirement (ANSI)  
Unit Main Input: 35.0 Amps MCA, 60 Amps MOP, 208 V, 8 AWG Wire Min.  
Supply Unit Voltage: 3 phs 208 V 60Hz

**Construction Features**

Housing constructed of heavy duty G90 galvanized steel • Vibration isolation • Ball bearing motors • Heavy duty, pre-lubricated bearings rated for 200,000 hours of operation • Service doors on both sides • Horizontal & down discharge • Large intake area ensures low pressure drop across unit • Spring loaded profile plates automatically adjust for any airflow - no manual setting required! • Weatherproof safety disconnect switch • Modular design provides design flexibility • Fully insulated casing

**Blower:**

24 Inch Mixed Flow Plenum Fan for size 3 MOD. Hub specified to match motor shaft.

**Temp Control:**

RTC Solutions • 40-90°F Discharge Temp Control • Field Wired On/Off Start Command

**Intake:**

Sloped Filtered Intake for Size #3 Modular Heater. 37.25" Wide X 51.625" Long X 35.188" High. Includes 2" MV EZ Kleen Metal Mesh Filter.

**Filters:**

6x MV EZ Kleen Metal Mesh Filter. 16"x 20"x 2" Used for heater and supply fan intakes. (3412)

**Selected Options:**

- Motorized Back Draft Damper 30" X 30" for Size 3 Standard & Modular Heater Units w/Extended Shaft, Standard Galvanized Construction, 3/4" Rear Flange, Low Leakage, NFBUP-S Actuator Included
- Low Fire Start. Allows the burner circuit to energize when the modulation control is in a low fire position.
- Gas Pressure Gauge, 0-35", 2.5" Diameter, 1/4" Thread Size
- Gas Pressure Gauge, -5 to +15 Inches Wc., 2.5" Diameter, 1/4" Thread Size
- VAV (Variable-Air-Volume) Wiring Package for Commercial Fans. Manual Speed Control Variable Frequency Drive Included
- Supply Variable Frequency Drive - 10 HP Max., 200/240 V, Three Phase, 29.0 A Max., NEMA 1 Enclosure, (Default Shipped Loose for Field Installation) PART NEEDS PROGRAMMING
- VFD factory mounted and wired on unit control panel.

**TK3-750-24D DIRECT FIRED HEATER**

1. DIRECT GAS FIRED HEATED MAKE UP AIR UNIT WITH 24" DIRECT DRIVE FAN AND 18" BURNER.
2. INTAKE HOOD WITH EZ FILTERS
3. DOWN DISCHARGE - AIR FLOW RIGHT -> LEFT
4. MOTORIZED BACK DRAFT DAMPER 30" X 30" FOR SIZE 3 STANDARD & MODULAR HEATER UNITS W/EXTENDED SHAFT, STANDARD GALVANIZED CONSTRUCTION, 3/4" REAR FLANGE, LOW LEAKAGE, NF8UP-S ACTUATOR INCLUDED
5. LOW FIRE START. ALLOWS THE BURNER CIRCUIT TO ENERGIZE WHEN THE MODULATION CONTROL IS IN A LOW FIRE POSITION.
6. GAS PRESSURE GAUGE, 0-35", 2.5" DIAMETER, 1/4" THREAD SIZE
7. GAS PRESSURE GAUGE, -5 TO +15 INCHES WC., 2.5" DIAMETER, 1/4" THREAD SIZE
8. VAV (VARIABLE-AIR-VOLUME) WIRING PACKAGE FOR COMMERCIAL FANS.  
MANUAL SPEED CONTROL VARIABLE FREQUENCY DRIVE INCLUDED

NOTE: SUPPLY DUCT MUST BE INSTALLED TO MEET SMACNA STANDARDS. A MINIMUM STRAIGHT DUCT LENGTH MUST BE MAINTAINED DOWNSTREAM OF UNIT DISCHARGE UNLESS OTHERWISE SPECIFIED. DO NOT RELY ON UNIT TO SUPPORT DUCT IN ANY WAY. FAILURE TO PROPERLY SIZE DUCTWORK MAY CAUSE SYSTEM EFFECTS AND REDUCE PERFORMANCE OF THE EQUIPMENT.

**SUPPLY SIDE HEATER INFORMATION:**

WINTER TEMPERATURE = 0°F. TEMP. RISE = 100°F.  
 BTUs CALCULATED OFF STANDARD AIR DENSITY  
 OUTPUT BTUs AT ALTITUDE OF 0.0 ft. = 669600  
 INPUT BTUs AT ALTITUDE OF 0.0 ft. = 727826

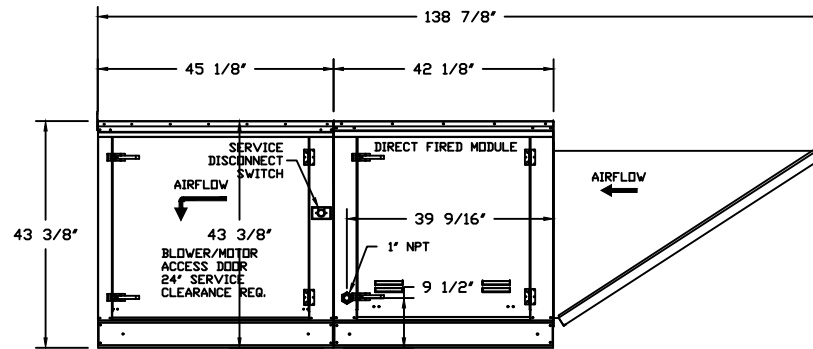
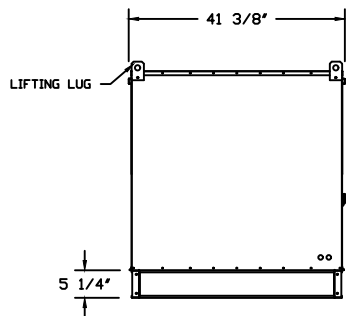
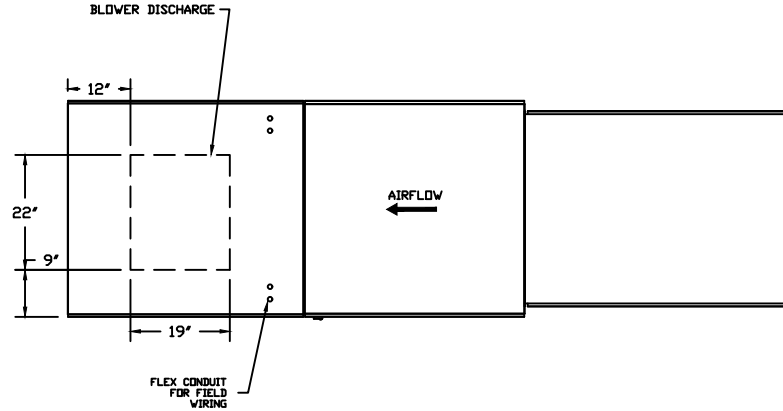

JOB	
LOCATION	
DATE	JOB #
DWG #	DRAWN BY
REV.	SCALE 1/4" = 1'-0"

<7200 10HP/3PH-208V> - HEATER PERFORMANCE CURVES.

7200 CFM, 0.687 SP @ 1669 RPM and 8.949 BHP at 0 feet and 100 deg F  
 \* Please note that these curves were adjusted for job specific temperature and altitude.

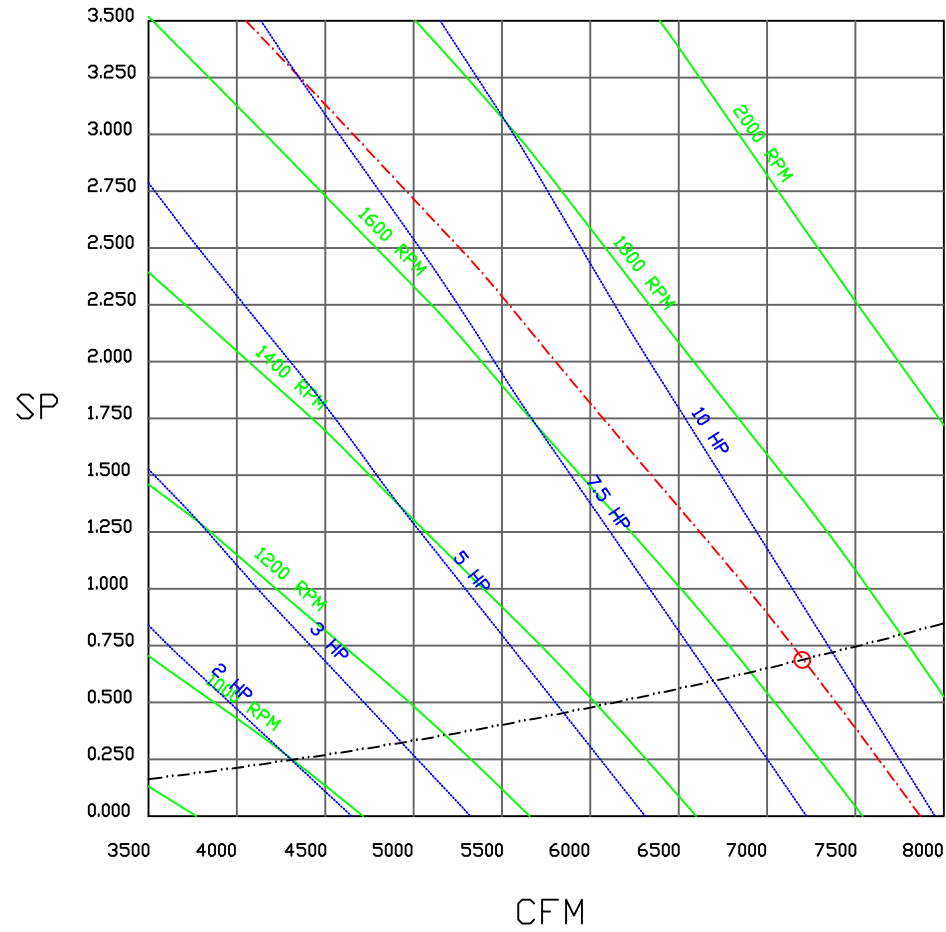

	<b>JOB</b>	
	<b>LOCATION</b>	
	<b>DATE</b>	<b>JOB #</b>
	<b>DWG #</b>	<b>DRAWN BY</b>
	<b>REV.</b>	<b>SCALE 3/8" = 1'-0"</b>

VFD Wiring

JOB NAKS Direct Fired Direct Drive MUA

DRAWING NUMBER

SHIP DATE

MODEL TK 1-5 Series Direct Drive

SMV SERIES VARIABLE FREQUENCY DRIVE

Installed Options  
Manual Control

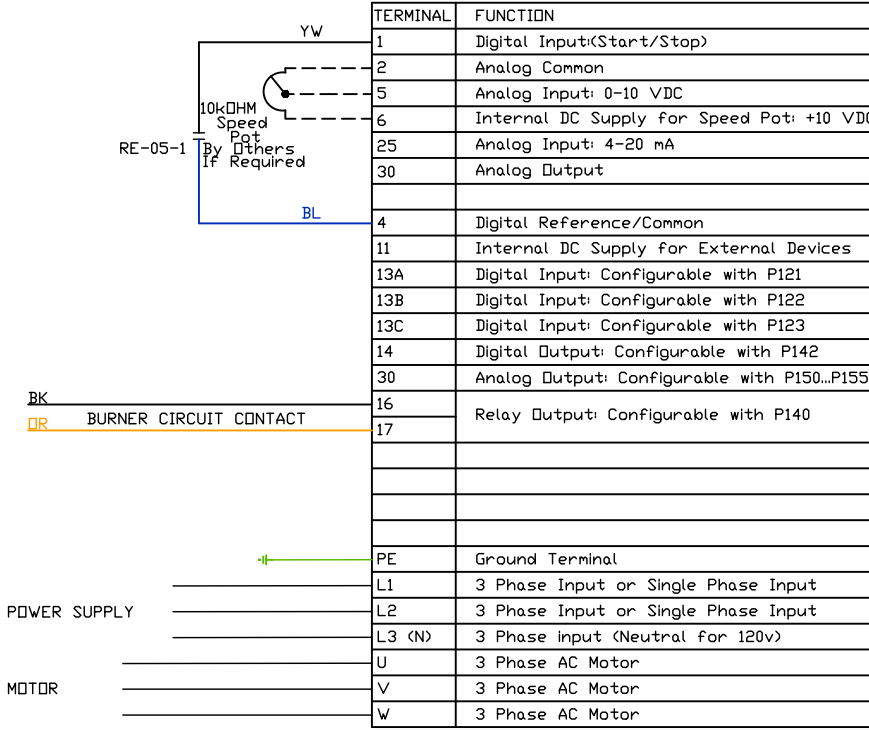

Component Identification

RE-05 VFD Start relay [2]

SUPPLY DRIVE PARAMETER SETTINGS\*

All external control wires to motor speed control should be 16-20 AWG shielded multiconductor cables and must not be run in the same conduit or raceway with any high power wiring. Ground Shielded Cable at the drive chassis ONLY.

EPM PROGRAM: VAV\_MANKUSE LG\_HP EPM IF >= 15HP)  
 P100 (Start Source) = 01 (Terminal Strip)  
 P102 = ##Minimum Frequency (Hz)  
 P103 = ##Maximum Frequency (Hz)  
 (P103 is based on max wheel RPM)  
 P110 (Start Method) = 03 (Auto Re-start)  
 P140 (Form A (NO) Relay) = 01 (Run)  
 P144 (Relay Inversion) = 00 (None)  
 P166 (Carrier Frequency) = 00 (4 kHz)  
 P171 (Current Limit) = 150 (% of Max I)

PG. 11 OF THE DRIVE MANUAL DESCRIBES THE PROPER INSTALLATION PROCEDURE

PG. 19 OF THE DRIVE MANUAL DESCRIBES THE PROGRAMMING PROCEDURE OF THE DRIVE

PG. 23 OF THE DRIVE MANUAL DESCRIBES THE PARAMETER SETTINGS OF THE DRIVE

\*NOTE: THE DEFAULT PASSWORD FROM THE FACTORY REQUIRED TO PROGRAM THE DRIVE IS '225'.

Adjust manually on all drives  
 P107 - 00 (If 120 or 208 VAC)  
 or 01 (If 230, 480 or 575 VAC)  
 P108 - Motor FLA x 100 / Drive Output Rating  
 P165 (Base Voltage) = Set to Motor Voltage (Preset@230V) P165 FDR STANDARD DRIVE ONLY  
 P167 (Base Frequency) = Calculated Per Fan  
 FDR KB PCU ONLY: P300 = 0

When Speed POT is Required the Following Parameters Must be Set:  
 P101 (Reference Source) = 01 (0-10 VDC)  
 P160 (Speed @ 0 VDC Signal) = Min Frequency  
 P161 (Speed @ 10 VDC Signal) = Max Frequency

IT MAY BE REQUIRED TO FULLY POWER DOWN THE DRIVE AND TURN BACK ON IN ORDER TO INITIATE NEW PARAMETER SETTINGS.

##Min. and Max. Frequency Settings override all other Preset speeds/Parameters.

MOTOR INFO  
 SUPPLY 10HP-208V-3P-27.0FLA  
 VFD PART: ESV752N02TXB

ELECTRICAL INFORMATION  
 MOTOR/CTRL CIRCUIT MCA: 35.0A  
 MOTOR/CTRL CIRCUIT MDP: 60A

NOTES  
 - - - - DENOTES FIELD WIRING  
 \_\_\_\_\_ DENOTES INTERNAL WIRING

WIRE COLOR  
 BK - BLACK YW - YELLOW  
 BL - BLUE GR - GREEN  
 BR - BRDN GY - GRAY  
 DR - ORANGE PR - PURPLE  
 RD - RED PK - PINK  
 WH - WHITE

GENERAL NOTES

# Direct Fired Heater Wiring

JOB NAKS Direct Fired Direct Drive MUA

DRAWING NUMBER

SHIP DATE

MODEL TK 1-5 Series Direct Drive

ATTENTION ELECTRICIAN!  
 DROP FDR DISCONNECT CONNECTION  
 IS FACTORY SUPPLIED  
 CONNECT POWER TO THE DROP

Installed Options  
 Field Wired Single Switch Control  
 Motorized Back Draft Damper

Discharge Temp. Control

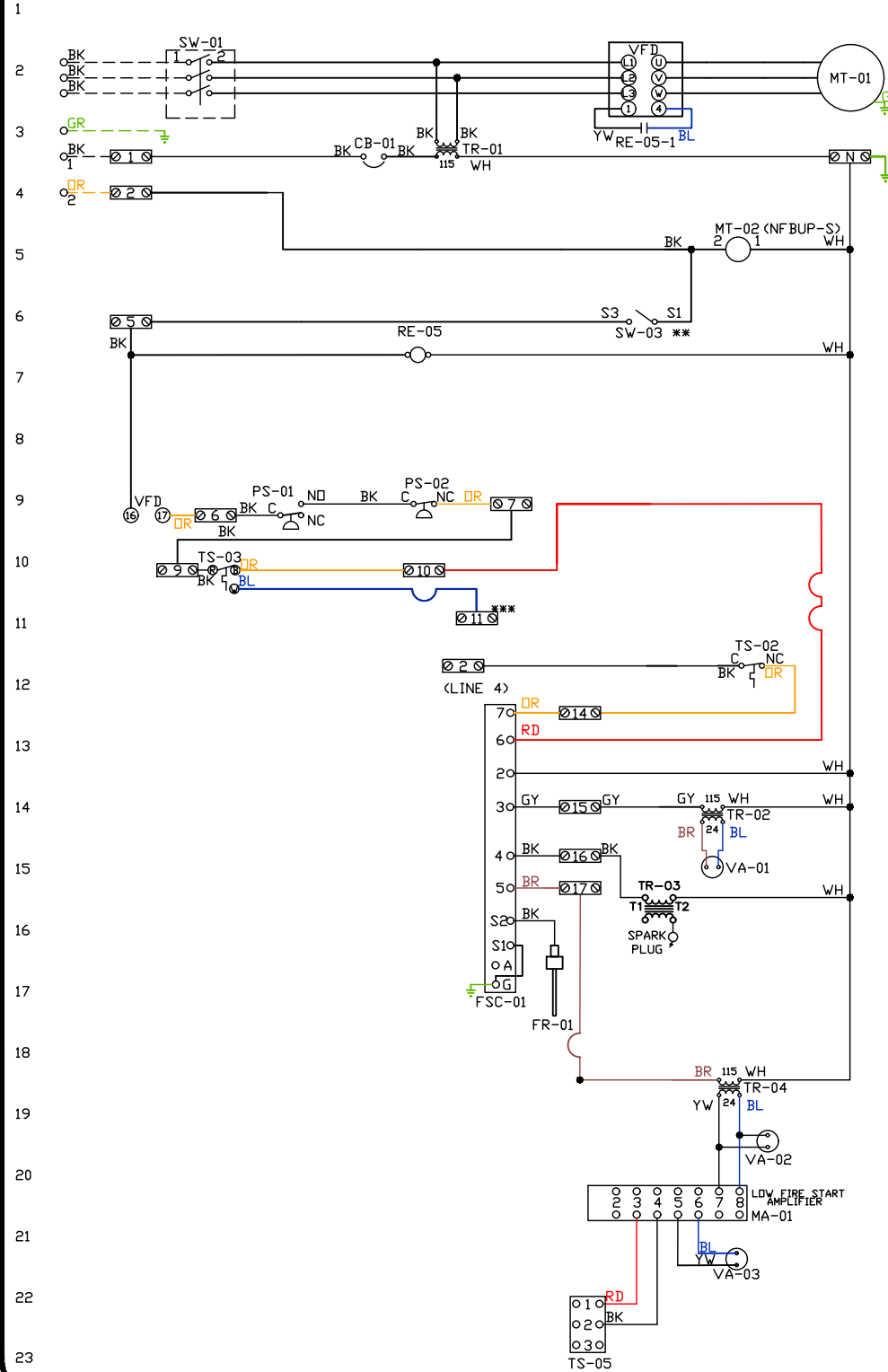

Label	Component Identification Description	Location
CB-01	Circuit breaker (2amp)	[3]
FR-01	Flame rod	[16]
FSC-01	Fireeye FSC	[11-14]
MA-01	Modulating amplifier	[19]
MT-01	Supply motor	[2]
MT-02	Damper motor	[5]
PS-01	Low Air-Flow Switch	[9]
PS-02	High Air-Flow Switch	[9]
RE-05	VFD Start Relay	[3][6]
SW-01	Main disconnect switch	[2]
SW-03	Damper end limit switch	[4]
TR-01	Power transformer(200va)	[12]
TR-02	Power transformer(20va)	[12]
TR-03	Ignition transformer	[14]
TR-04	Power transformer(20va)	[17]
TS-02	High temp limit switch	[10]
TS-03	Intake Air Sensor	[10]
TS-05	Discharge Air Sensor	[21]
VA-01	Pilot gas valve	[13]
VA-02	Main gas valve	[18]
VA-03	Modulating gas valve	[20]

**MOTOR INFO**  
 SUPPLY 10HP-208V-3P-27.0FLA  
 VFD PART: ESV752N02TXB

**ELECTRICAL INFORMATION**  
 MOTOR/CTRL CIRCUIT MCB: 35.0A  
 MOTOR/CTRL CIRCUIT MDP: 60A

**NOTES**  
 - - - - DENOTES FIELD WIRING  
 \_\_\_\_\_ DENOTES INTERNAL WIRING

\*\* TERMINALS S4 AND S6 USED ON NF & AF SERIES ACTUATORS  
 \*\*\* TERMINAL 11 PROVIDES COOLING CONNECTION

WIRE COLOR	SOCKET STYLE "COLONY" RELAY
BK - BLACK	NO 4   3   1
BL - BLUE	NC 2   1
GR - GREEN	COM 8   7
BR - BROWN	COM 6   5
GY - GRAY	
RD - RED	
WH - WHITE	
PK - PINK	
DR - DRANGE	
PR - PURPLE	

# Installation Wiring

JOB NAKS Direct Fired MUA

DRAWING NUMBER

SHIP DATE

MODEL TK 1-5 Series

Installed Options



Field Wired On/Off Switch

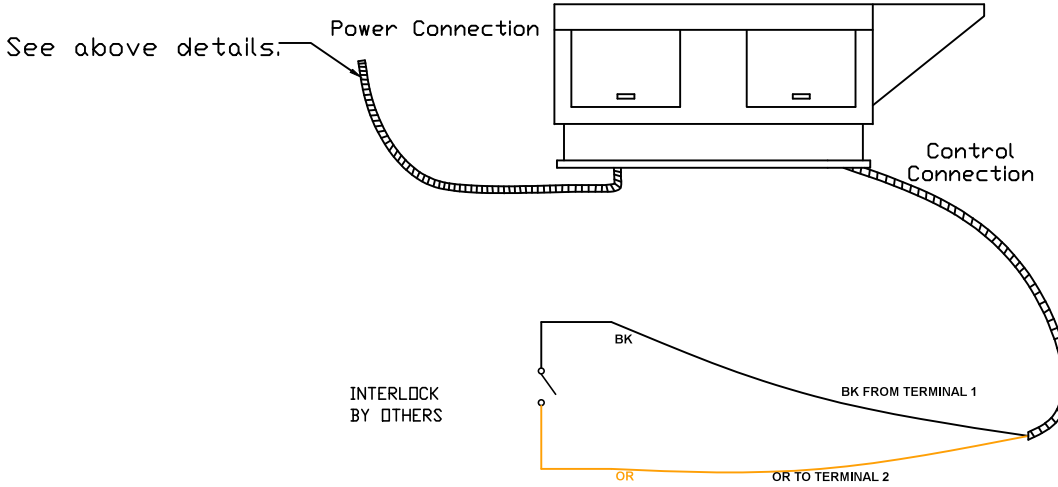

NOTES

- WIRE COLOR
- BK - BLACK
  - BL - BLUE
  - BR - BROWN
  - OR - ORANGE
  - RD - RED
  - WH - WHITE
  - YW - YELLOW
  - GR - GREEN
  - GY - GRAY
  - PR - PURPLE
  - PK - PINK