



Order # 3697308 - NAKS DD TK-USBI Utility Sets

Fan #5 TK-USBI-15DD-RM (279 lbs.)

Tag: 2500 1.5hp/3ph-VFD

Direct Drive Exhaust Only Unit With 15.750" Utility Set Exhaust Fan w/ 2" Grease Drain. Clockwise Rotation When Looking At Inlet.

**Exhaust Motor:**

Model DTP1/54, 1.500 HP, 3 Phs, 208 V, 60Hz, 4.4 FLA, ODP, Premium (E-Plus3) Eff.

**Exhaust Performance:**

Volume: 2500 cfm

RPM: 1677

TS: 6915 ft/min

SP: 1.400" w.g.

BHP: 1.22

Discharge Velocity: 1738 FPM

Altitude: 0'

Ambient Temp: 70°F

**Exhaust Installation Information:**

Unit Main Input: 5.5 Amps MCA, 15 Amps MOP, 208 V, 14 AWG Wire Min.

Exhaust Unit Voltage: 3 phs 208 V 60Hz



**Selected Options:**

- BI15 - 24" High Discharge Extension Assembly.
- BI - Discharge Orientation - Vertical Upper Left - CW Looking At Inlet.
- BI15 - 16" Flanged Grease Duct Connection.
- Grease Cup for Utility Sets. Option for Utility Sets.
- VAV (Variable-Air-Volume) Wiring Package for Commercial Fans. Manual Speed Control Variable Frequency Drive Included
- Exhaust Variable Frequency Drive - 1-1/2 HP Max., 200/240 V, Single or Three Phase Input, 6.0 A Max., NEMA 1 Enclosure, (Default is Shipped Loose for Field Installation) PART NEEDS PROGRAMMING
- VFD factory mounted and wired in unit control vestibule.

***EXHAUST FAN INFORMATION***

FAN UNIT NO.	TAG	FAN UNIT MODEL #	CFM	ESP.	RPM	H.P.	B.H.P.	Ø	VOLT	FLA	DISCHARGE VELOCITY	WEIGHT (LBS.)
1	2500 1.5hp/3ph-VFD	TK-USBI-15DD-RM	2500	1.400	1677	1.500	1.2200	3	208	4.4	1738 FPM	279

***FAN OPTIONS***

FAN UNIT NO.	TAG	OPTION (Qty. - Descr.)
1	2500 1.5hp/3ph-VFD	1 - BI15 - 24' Discharge Extension.
		1 - BI - Discharge Orientation Vertical Upper Left - CW Inlet Side.
		1 - BI15 - Inlet Connection Standard 16' Flanged Grease Duct.
		1 - Utility Set Grease Cup
		1 - VAV Package w/ Manual Control (VFD Included)
		1 - VFD factory mounted and wired in Exhaust Fan.

***FAN ACCESSORIES***

FAN UNIT NO.	TAG	EXHAUST		
		GREASE CUP	GRAVITY DAMPER	WALL MOUNT
1	2500 1.5hp/3ph-VFD	YES		

		<i>JOB</i>	
		<i>LOCATION</i>	
		<i>DATE</i>	<i>JOB #</i>
		<i>DWG #</i>	<i>DRAWN BY</i>
		<i>REV.</i>	<i>SCALE 3/8" = 1'-0"</i>

(2500 1.5HP/3PH-VFD) - TK-USBI-15DD-RM EXHAUST FAN

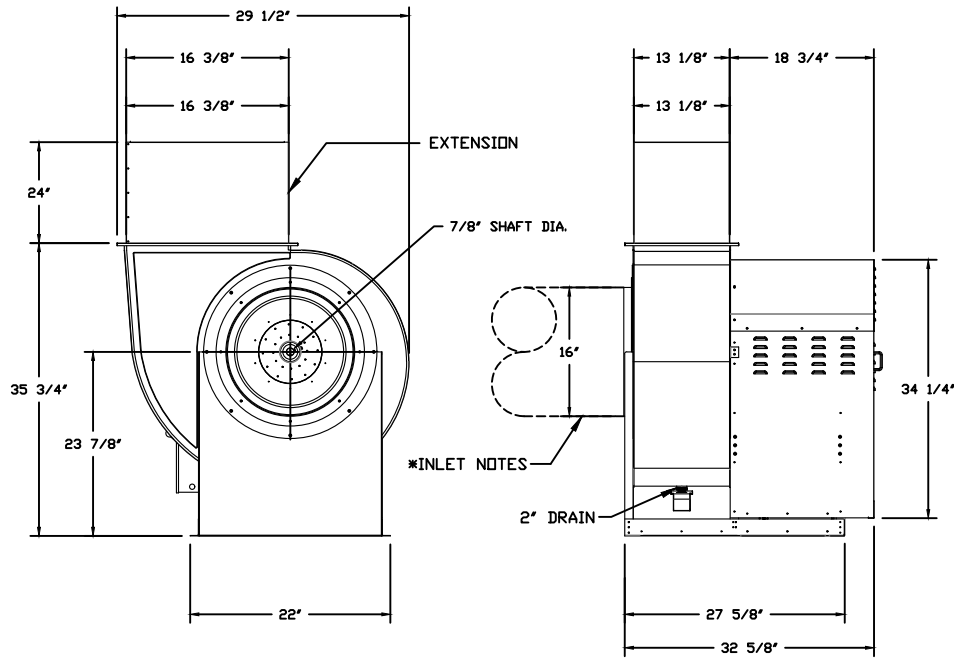

**FEATURES:**

- ROOF MOUNTED FANS
- UL705
- UL762 AND ULC-S645 (RESTAURANT MODEL)
- HIGH HEAT OPERATION DIRECT DRIVE 350°F (176°C)
- HIGH HEAT OPERATION BELT DRIVE 350°F (176°C)
- HEAT SLINGER
- WEATHERPROOF DISCONNECT
- GREASE CLASSIFICATION TESTING
- 2" DRAIN
- MOTOR WEATHER COVER
- FULLY SEALED SCROLL HOUSING
- SCROLL ACCESS DOOR
- FLANGE 1 1/4" - 11 THRU 20.
- FLANGE 2" - 24 THRU 36.

**OPTIONS**

- BI15 - 24" DISCHARGE EXTENSION.
- BI - DISCHARGE ORIENTATION VERTICAL UPPER LEFT - CW INLET SIDE.
- BI15 - INLET CONNECTION STANDARD 16" FLANGED GREASE DUCT.
- UTILITY SET GREASE CUP.
- VAV PACKAGE W/ MANUAL CONTROL (VFD INCLUDED).
- VFD FACTORY MOUNTED AND WIRED IN EXHAUST FAN.

**NORMAL TEMPERATURE TEST DIRECT DRIVE**  
 EXHAUST FAN MUST OPERATE CONTINUOUSLY WHILE EXHAUSTING AIR AT 350°F (176°C) UNTIL ALL FAN PARTS HAVE REACHED THERMAL EQUILIBRIUM, AND WITHOUT ANY DETERIORATING EFFECTS TO THE FAN WHICH WOULD CAUSE UNSAFE OPERATION.

**\* INLET NOTES:**  
 LENGTH OF THE STRAIGHT DUCT ON THE INLET TO BE 3 TIMES THE EQUIVALENT DUCT DIAMETER BEFORE CONNECTING TO ANY FITTINGS SUCH AS ELBOWS TO AVOID SYSTEM EFFECT.

	<b>JOB</b>	
	<b>LOCATION</b>	
	<b>DATE</b>	<b>JOB #</b>
	<b>DWG #</b>	<b>DRAWN BY</b>
	<b>REV.</b>	<b>SCALE 3/8" = 1'-0"</b>

**naKS** NORTH AMERICAN KITCHEN SOLUTIONS INCORPORATED

(2500 1.5hp/3ph-VFD) - EXHAUST PERFORMANCE CURVES.

2500 CFM, 1.4 SP @ 1677 RPM and 1.22 BHP at 0 feet and 70 deg F

\* Please note that these curves were adjusted for job specific temperature and altitude.

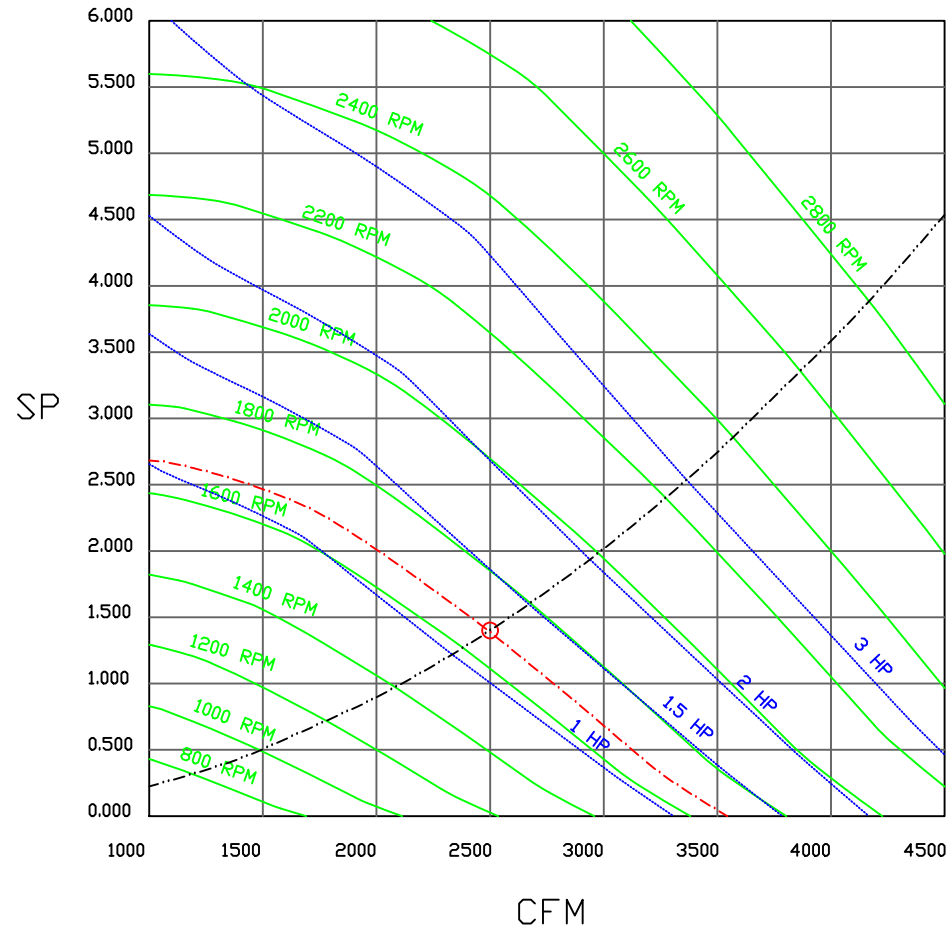

JOB	
LOCATION	
DATE	JOB #
DWG #	DRAWN BY
REV.	SCALE 3/8" = 1'-0"

# Exhaust Fan Wiring

JOB NAKS DD TK-USBI Utility Sets

DRAWING NUMBER Fan Wiring Schem

SHIP DATE

MODEL TK-USBI-15DD-RM

## Installed Options

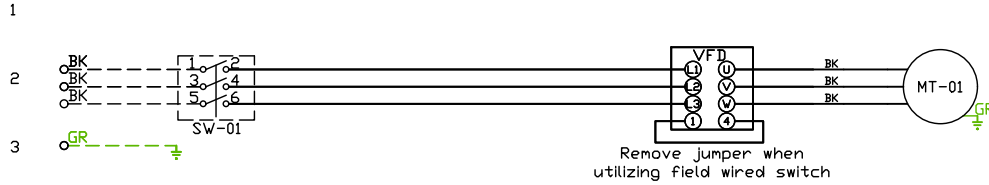

Component Identification		
Label	Description	Location
MT-01	Fan Motor	[2]
MT-02	Damper Motor	[2]
SW-01	Main disconnect switch	[2]

**MOTOR INFO**  
 EXHAUST 1.5HP-208V-3P-4.4FLA  
 VFD PART: ESV112N02YXB

**ELECTRICAL INFORMATION**  
 MOTOR/CTRL MCA: 5.5A  
 MOTOR/CTRL MCB: 15A

**NOTES**  
 - - - - DENOTES FIELD WIRING  
 \_\_\_\_\_ DENOTES INTERNAL WIRING

**WIRE COLOR**

BK - BLACK	YW - YELLOW
BL - BLUE	GR - GREEN
BR - BROWN	GY - GRAY
OR - ORANGE	PR - PURPLE
RD - RED	PK - PINK
WH - WHITE	

1  
2  
3  
4  
5  
6  
7  
8  
9  
10  
11  
12  
13  
14  
15  
16  
17  
18  
19  
20  
21  
22  
23

VFD Wiring

JOB NAKS DD TK-USBI Utility Sets

DRAWING NUMBER VFD Schem

SHIP DATE

MODEL TK-USBI-15DD-RM

SMV SERIES VARIABLE FREQUENCY DRIVE

Installed Options  
Manual Control

TERMINAL	FUNCTION
1	Digital Input(Start/Stop)
2	Analog Common
5	Analog Input: 0-10 VDC
6	Internal DC Supply for Speed Pot: +10 VDC
25	Analog Input: 4-20 mA
30	Analog Output
4	Digital Reference/Common
11	Internal DC Supply for External Devices
13A	Digital Input: Configurable with P121
13B	Digital Input: Configurable with P122
13C	Digital Input: Configurable with P123
14	Digital Output: Configurable with P142
30	Analog Output: Configurable with P150...P155
16	Relay Output: Configurable with P140
17	
PE	Ground Terminal
L1	3 Phase Input or Single Phase Input
L2	3 Phase Input or Single Phase Input
L3 (N)	3 Phase input (Neutral for 120v)
U	3 Phase AC Motor
V	3 Phase AC Motor
W	3 Phase AC Motor

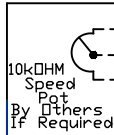

NOT USED FOR EXHAUST FANS  
OR NON-HEATED SUPPLY FANS  
BURNER CIRCUIT CONTACT

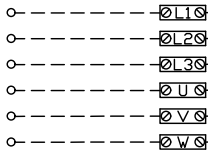

TERMINAL BLOCKS  
LOCATED IN HEATER UNIT  
(IF SINGLE PHASE INPUT, UNIT MAY  
NOT CONTAIN ALL TERMINAL BLOCKS)

EXHAUST FANS AND NON-HEATED  
UNITS DO NOT HAVE TERMINALS

All external control wires to motor speed control should be 16-20 AWG shielded multiconductor cables and must not be run in the same conduit or raceway with any high power wiring. Ground Shielded Cable at the drive chassis ONLY.

PG. 11 OF THE DRIVE MANUAL DESCRIBES THE PROPER  
INSTALLATION PROCEDURE

PG. 19 OF THE DRIVE MANUAL DESCRIBES THE PROGRAMMING  
PROCEDURE OF THE DRIVE

PG. 23 OF THE DRIVE MANUAL DESCRIBES THE PARAMETER  
SETTINGS OF THE DRIVE

NOTE: THE DEFAULT PASSWORD FROM THE FACTORY REQUIRED  
TO PROGRAM THE DRIVE IS '225'.

SUPPLY DRIVE PARAMETER SETTINGS\*

EPH PROGRAM: VAV\_MAKUSE LG\_HP EPH IF >= 15HP)  
P100 (Start Source) = 01 (Terminal Strip)  
P102 = ##Minimum Frequency (Hz)  
P103 = ##Maximum Frequency (Hz)  
(P103 is based on max wheel RPM)  
P110 (Start Method) = 03 (Auto Re-start)  
P140 (Form A [NO] Relay) = 01 (Run)  
P144 (Relay Inversion) = 00 (None)  
P166 (Carrier Frequency) = 00 (4 kHz)  
P171 (Current Limit) = 150 (% of Max I)

Adjust manually on all drives  
P107 - 00 (IF 120 or 208 VAC)  
or 01 (IF 230, 480 or 575 VAC)  
P108 - Motor FLA x 100 / Drive Output Rating  
P165 (Base Voltage) = Set to Motor Voltage  
(Preset@230V) P165 FOR STANDARD DRIVE ONLY  
P167 (Base Frequency) = Calculated Per Fan  
FOR KB PCU ONLY: P300 = 0

When Speed POT is Required the Following  
Parameters Must be Set:  
P101 (Reference Source) = 01 (0-10 VDC)  
P160 (Speed @ 0 VDC Signal) = Min Frequency  
P161 (Speed @ 10 VDC Signal) = Max Frequency

IT MAY BE REQUIRED TO FULLY POWER DOWN THE DRIVE  
AND TURN BACK ON IN ORDER TO INITIATE NEW  
PARAMETER SETTINGS.

##Min. and Max. Frequency Settings override all  
other Preset speeds/Parameters.

GENERAL NOTES

Component Identification

MOTOR INFO  
EXHAUST 1.5HP-208V-3P-4.4FLA  
VFD PART: ESV112N02YXB

ELECTRICAL INFORMATION  
MOTOR/CTRL MCA: 5.5A  
MOTOR/CTRL MDP: 15A

NOTES

--- DENOTES FIELD WIRING  
\_\_\_\_\_ DENOTES INTERNAL WIRING

WIRE COLOR

BK - BLACK YW - YELLOW  
BL - BLUE GR - GREEN  
BR - BRDWN GY - GRAY  
OR - ORANGE PR - PURPLE  
RD - RED PK - PINK  
WH - WHITE