

DUCTWORK				
A	B	C	D	QTY.
12"	14"	12"	1"	1

CURBPLATE		
WIDTH	LENG.	QTY.
18"	18"	1

FAN MODEL	A	B	C	D
28D	17 1/2"	17 1/2"	2"	4"

FAN MODEL	A	B	C	D	WT. LBS.
28D	26 1/2"	20 7/8"	16 1/2"	19" SQ.	60 LBS.

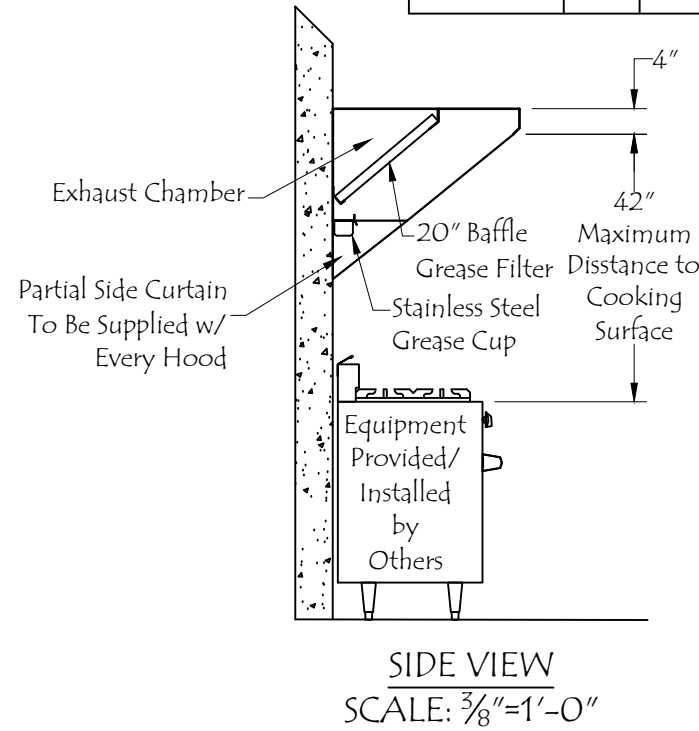
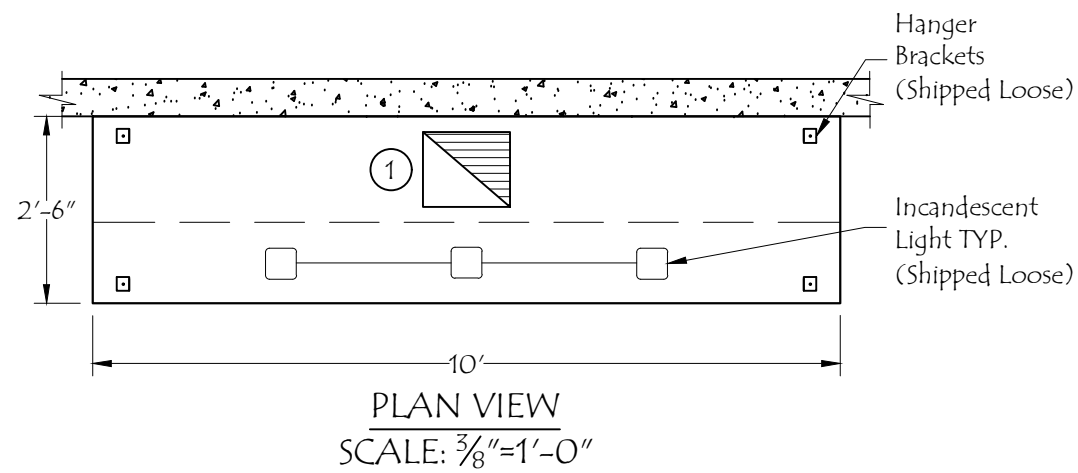

**\*IT IS THE RESPONSIBILITY OF THE ARCHITECT/OWNER TO ENSURE THAT THE HOOD CLEARANCE FROM LIMITED-COMBUSTIBLE MATERIALS IS IN COMPLIANCE WITH LOCAL CODE REQUIREMENTS**

**\*ALL EQUIPMENT IS UL LISTED COMPONENTS\***  
 HOODMART HOODS ARE BUILT IN COMPLIANCE WITH :  
 NFPA #96 & UL710  
 AND ARE RECOGNIZED BY ONE OR MORE OF THE FOLLOWING:  
 - NSF INTERNATIONAL -UL



HOOD NO.	MODEL	LENGTH	MAX. COOKING TEMP.	① EXHAUST PLENUM					② SUPPLY PLENUM					HOOD CONSTRUCTION	
				TOTAL EXH. CFM	RISER(S)				TOTAL SUP. CFM	RISER(S)					
				WIDTH	LENG.	QTY.	CFM	S.P.	WIDTH	LENG.	QTY.	CFM	S.P.		
1	EXSS010C 10X30	120"NOM 120"OD	700 Deg.	2000	12"	14"	1	2000	.375"	-	-	-	-	-	STAINLESS STEEL

HOOD NO.	FILTER(S)				LIGHT(S)			UTILITY CABINET(S)				EST. HOOD WEIGHT	
	TYPE	QTY.	HEIGHT	LENGTH	TYPE	QTY.	WIRE GUARD	TYPE	SIZE	ELECTRICAL MODEL #	SWITCHES QUANTITY		LOCATION
1	S.S. BAFFLE W/ HANDLES	0	20"	16"	INCANDESCENT LIGHT	3	NO	--	--	--	--	--	235 LBS.

FAN UNIT NO.	FAN UNIT MODEL #	EXHAUST FAN									SUPPLY FAN										
		MODEL	TAG	CFM	S.P.	RPM	H.P.	Ø	VOLT	FLA	BLOWER	HOUSING	TAG	CFM	S.P.	RPM	H.P.	Ø	VOLT	FLA	
1	28D EF-1	28D	EF-1	2000	.375"	1625	1/2	1	115	5.6											
2																					

REVISIONS				
REV	DATE	DRWN BY	APP'D BY	REMARKS
-	-	-	-	-

**HOODMART.**  
 YOUR ONE STOP HOOD SHOP

172 REASER COURT  
 ELYRIA, OHIO 44035

TOLL FREE : 1-800-715-1014  
 FAX: 1-800-716-1214

EQUIPMENT SCHEDULE

CONCESSION CANOPY

CONTRACT NO. - ITEM NO. -

JOB: -  
 LOC: -  
 CUST: -  
 CUST#: -

DATE - SCALE AS NOTED  
 DRAWN BY - APPROVED BY -

DWG#11913

SHT -  
 OF -