

MODEL# 36B
UL762 UPBLAST EXHAUST FAN
BELT DRIVE

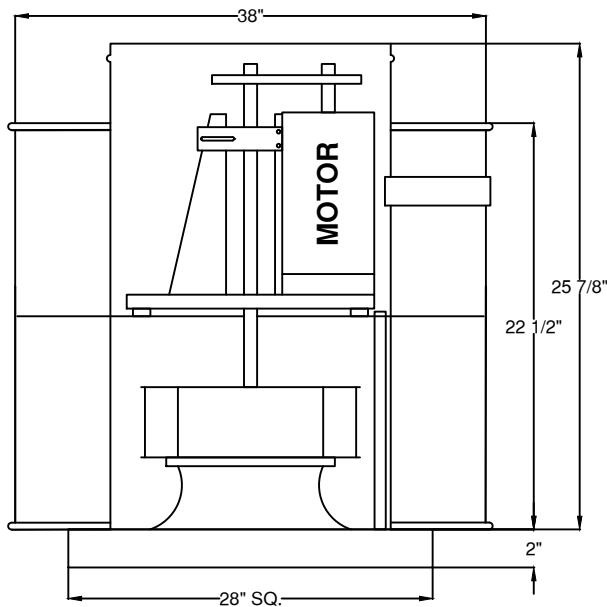

DIMENSIONAL DATA
26 1/2" SQ. CURB

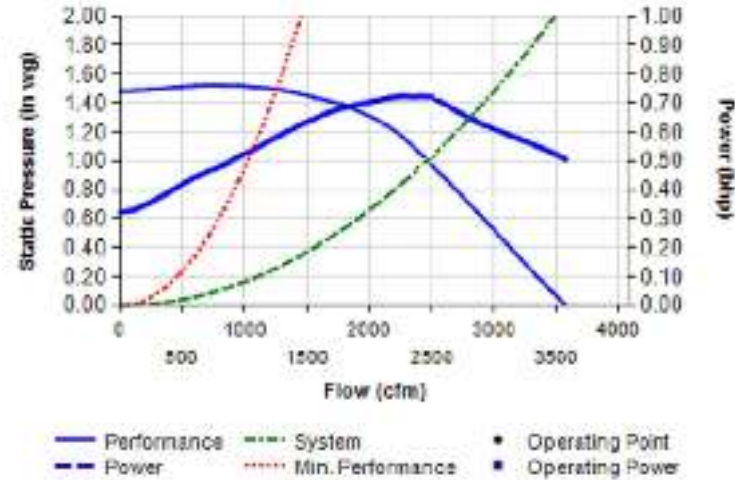

PERFORMANCE DATA

PHASE	1	VOLTS	115/230
AMPS	13/6.5	HP	1

RPM	.000" S.P.		.250" S.P.		.50" S.P.		.75" S.P.		1.00" S.P.		1.25" S.P.		1.50" S.P.		1.75" S.P.	
	CFM	Sone	CFM	Sone	CFM	Sone	CFM	Sone	CFM	Sone	CFM	Sone	CFM	Sone	CFM	Sone
1154	3067	15.9	2739	14.9	2423	15.0	2092	14.4	1599	14.3	-	-	-	-	-	-
1346	3578	18.4	3293	19.0	3022	18.4	2749	18.5	2464	19.4	2084	19.2	-	-	-	-
1546	4109	21.0	3860	23.0	3621	22.0	3387	23.0	3148	25.0	2902	25.0	2644	24.0	2220	24.0

STANDARD FEATURES

- HEAVY GAUGE ALUMINUM HOUSING
- 1 YEAR LIMITED WARRANTY ON ALL ELECTRIC MOTORS
- FACTORY SET DRIVE
- BELT DRIVEN MOTORS ARE ENCLOSED IN WEATHER-TIGHT COMPARTMENTS
- AVERAGE UNIT WEIGHT: 128 LBS
- AVERAGE SHIPPING WEIGHT: 205 LBS



LISTED

FANS
UL 762

11042 1/20