

MODEL# **48B**

UL762 UPBLAST EXHAUST FAN BELT DRIVE

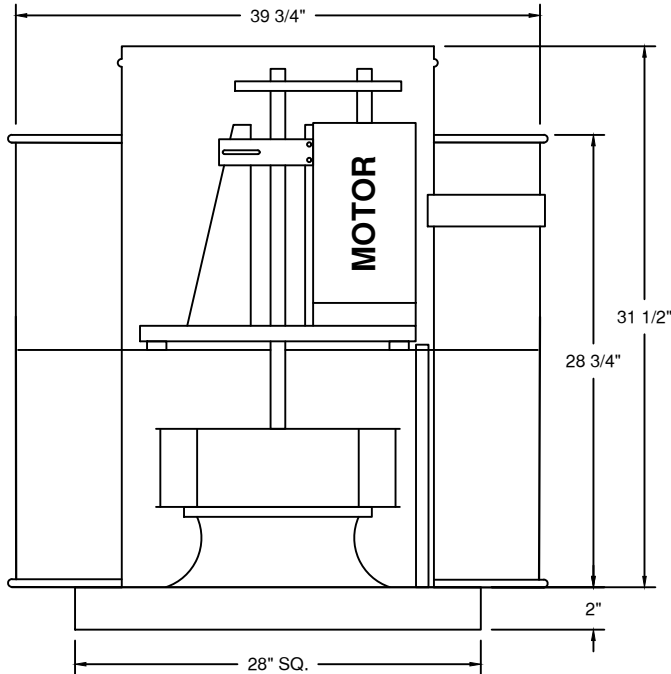

DIMENSIONAL DATA
26 1/2" SQ. CURB

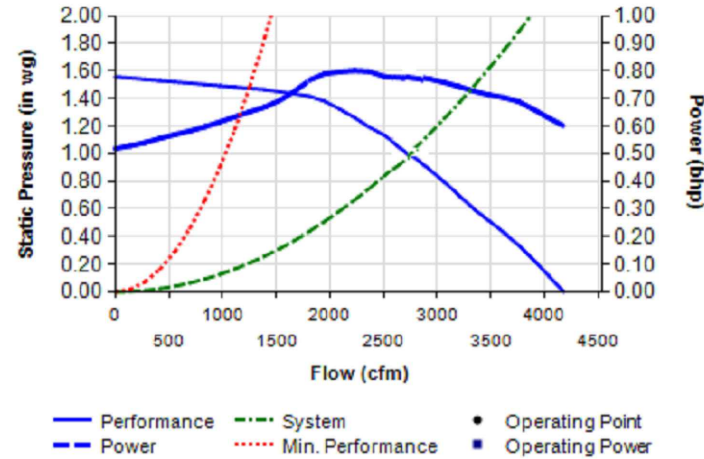

PERFORMANCE DATA

| | | | |
|-------|--------|-------|---------|
| PHASE | 1 | VOLTS | 115/230 |
| AMPS | 13/6.5 | HP | 1 |

| RPM | .000" S.P. | | .250" S.P. | | .50" S.P. | | .75" S.P. | | 1.00" S.P. | | 1.25" S.P. | | 1.50" S.P. | |
|------|------------|------|------------|------|-----------|------|-----------|------|------------|------|------------|------|------------|------|
| | CFM | Sone | CFM | Sone | CFM | Sone | CFM | Sone | CFM | Sone | CFM | Sone | CFM | Sone |
| 949 | 3513 | 13.3 | 3146 | 13.4 | 2677 | 13.3 | 2220 | 12.5 | - | - | - | - | - | - |
| 1129 | 4179 | 19.5 | 3874 | 17.2 | 3499 | 17.4 | 3126 | 15.8 | 2740 | 14.2 | 2263 | 14.7 | - | - |
| 1246 | 4613 | 18.9 | 4335 | 18.7 | 4026 | 17.8 | 3657 | 16.9 | 3340 | 16.2 | 2977 | 15.5 | 2540 | 14.1 |

STANDARD FEATURES

- HEAVY GAUGE ALUMINUM HOUSING
- 1 YEAR LIMITED WARRANTY ON ALL ELECTRIC MOTORS
- FACTORY SET DRIVE
- BELT DRIVEN MOTORS ARE ENCLOSED IN WEATHER-TIGHT COMPARTMENTS
- AVERAGE UNIT WEIGHT: 152 LBS
- AVERAGE SHIPPING WEIGHT: 252 LBS



FANS
UL 762