

**MODEL# 48B3**  
**UL762 UPBLAST EXHAUST FAN**  
**BELT DRIVE**

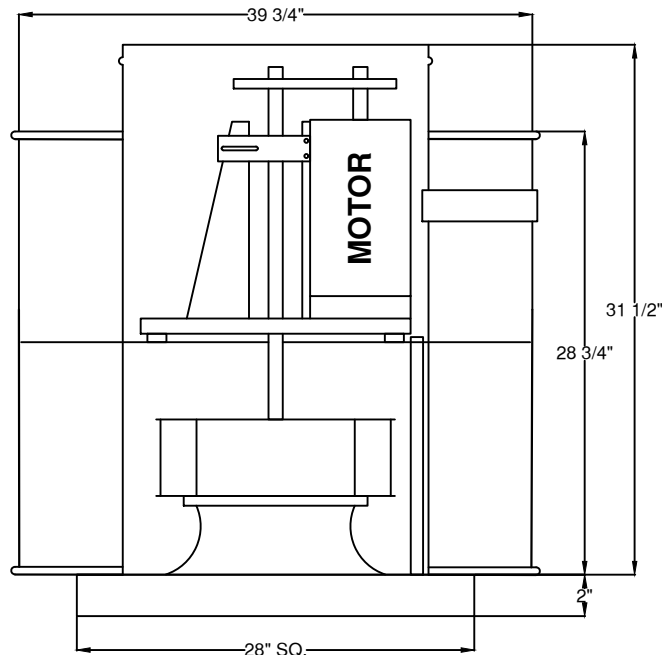

**DIMENSIONAL DATA**  
**26 1/2" SQ. CURB**

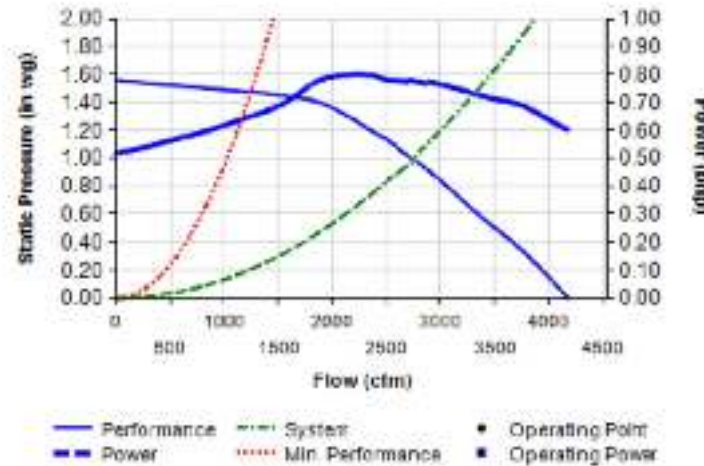

**PERFORMANCE DATA**

<b>PHASE</b>	3	<b>VOLTS</b>	230/460
<b>AMPS</b>	5.5/2.8	<b>HP</b>	1

RPM	.000" S.P.		.250" S.P.		.50" S.P.		.75" S.P.		1.00" S.P.		1.25" S.P.		1.50" S.P.	
	CFM	Sone	CFM	Sone	CFM	Sone	CFM	Sone	CFM	Sone	CFM	Sone	CFM	Sone
949	3513	13.3	3146	13.4	2677	13.3	2220	12.5	-	-	-	-	-	-
1129	4179	19.5	3874	17.2	3499	17.4	3126	15.8	2740	14.2	2263	14.7	-	-
1246	4613	18.9	4335	18.7	4026	17.8	3657	16.9	3340	16.2	2977	15.5	2540	14.1

**STANDARD FEATURES**

- HEAVY GAUGE ALUMINUM HOUSING
- 1 YEAR LIMITED WARRANTY ON ALL ELECTRIC MOTORS
- FACTORY SET DRIVE
- BELT DRIVEN MOTORS ARE ENCLOSED IN WEATHER-TIGHT COMPARTMENTS
- AVERAGE UNIT WEIGHT: 152 LBS
- AVERAGE SHIPPING WEIGHT: 240 LBS



**LISTED**

FANS  
**UL 762**

11048 1/20