

**MODEL# 28D**  
**UL762 UPBLAST EXHAUST FAN**  
**DIRECT DRIVE**

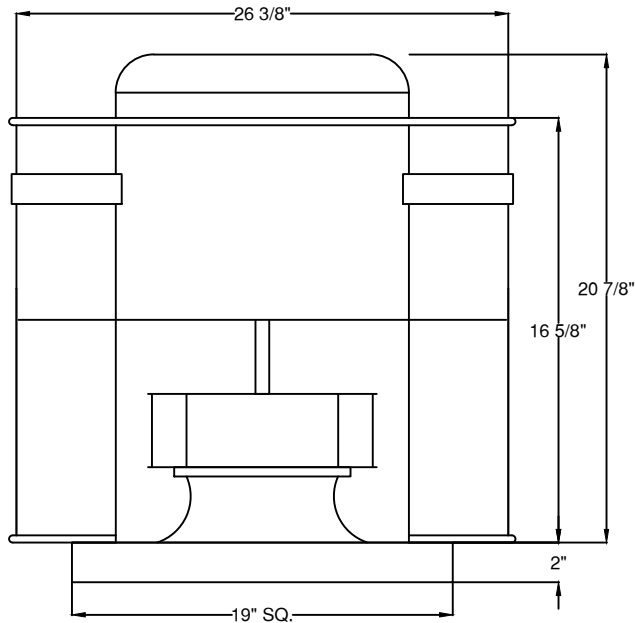

**DIMENSIONAL DATA**  
**17 1/2" SQ. CURB**

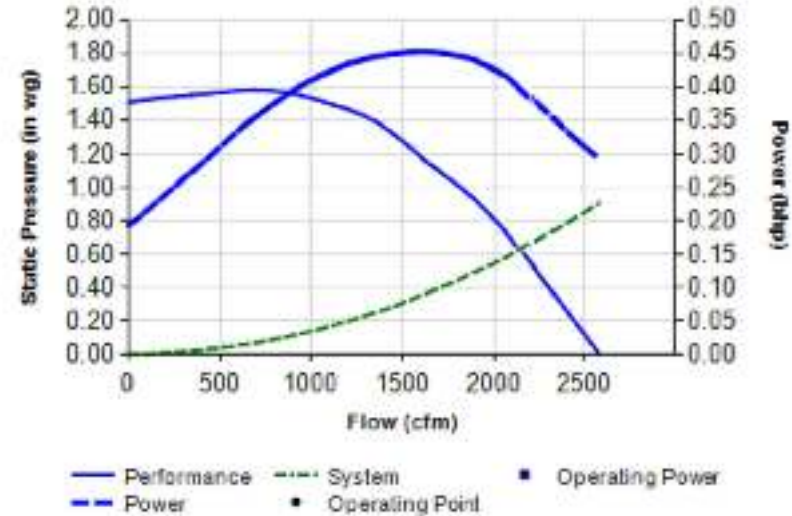

**PERFORMANCE DATA**

<b>PHASE</b>	1	<b>VOLTS</b>	115
<b>AMPS</b>	5.6	<b>HP</b>	1/2

RPM	.000" S.P.		.125" S.P.		.250" S.P.		.375" S.P.		.50" S.P.		.625" S.P.		.750" S.P.		1.0" S.P.		1.25" S.P.	
	CFM	Sone	CFM	Sone	CFM	Sone	CFM	Sone	CFM	Sone	CFM	Sone	CFM	Sone	CFM	Sone	CFM	Sone
1625	2577	17.60	2490	17.4	2404	17.10	2318	16.60	2231	16.20	2142	16.20	2048	16.20	1816	15.10	1530	15.50

**STANDARD FEATURES**

- HEAVY GAUGE ALUMINUM HOUSING
- 1 YEAR LIMITED WARRANTY ON ALL ELECTRIC MOTORS
- FACTORY SET DRIVE
- DIRECT DRIVEN MOTORS ARE ENCLOSED IN WEATHER-TIGHT COMPARTMENTS
- AVERAGE UNIT WEIGHT: 50 LBS
- AVERAGE SHIPPING WEIGHT: 72 LBS



**LISTED**

FANS

**UL 762**

11066 1/20