

DUCTWORK				
A	B	C	D	QTY.
10"	10"	12"	1"	2

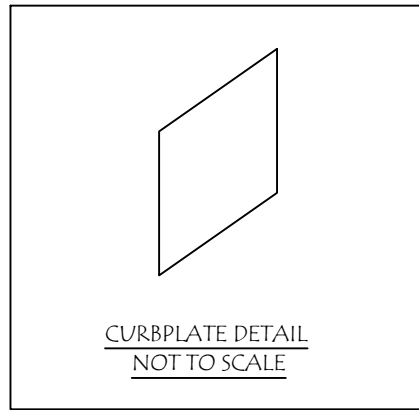

CURBPLATE		
WIDTH	LENG.	QTY.
18"	18"	2

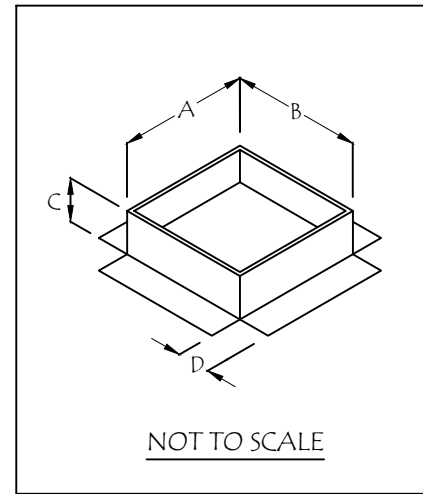

FAN MODEL	A	B	C	D	QTY
20D	17 1/2"	17 1/2"	2"	4"	2

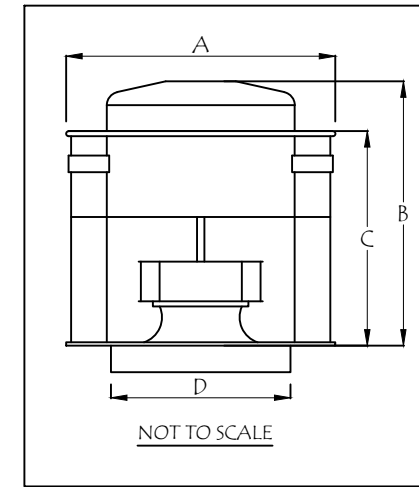

FAN MODEL	A	B	C	D	QTY	WT. LBS.
20D	26 3/8"	19 1/2"	16 3/8"	19" SQ.	2	60 LBS.

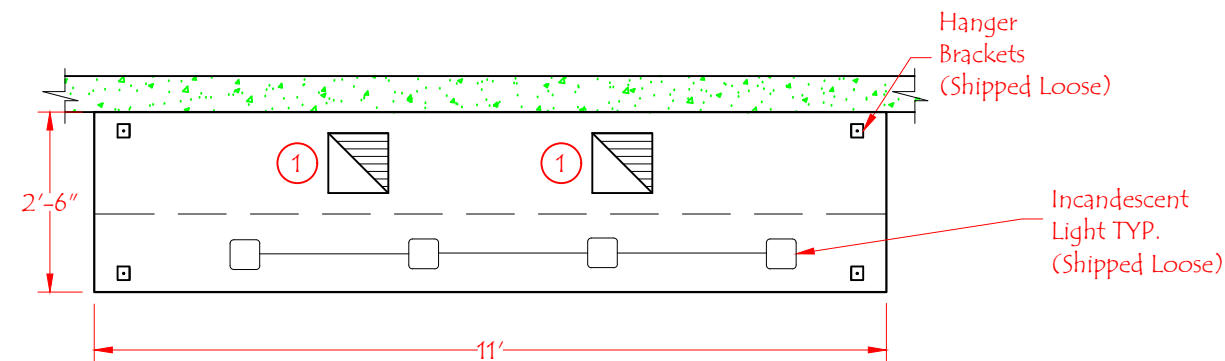
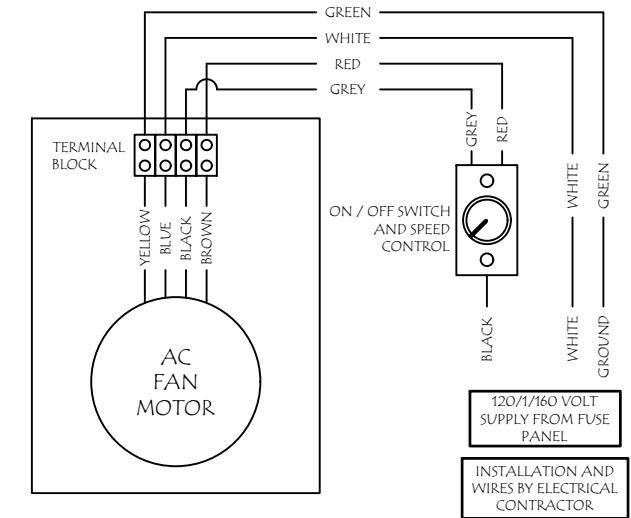

PLAN VIEW
SCALE: 3/8"=1'-0"

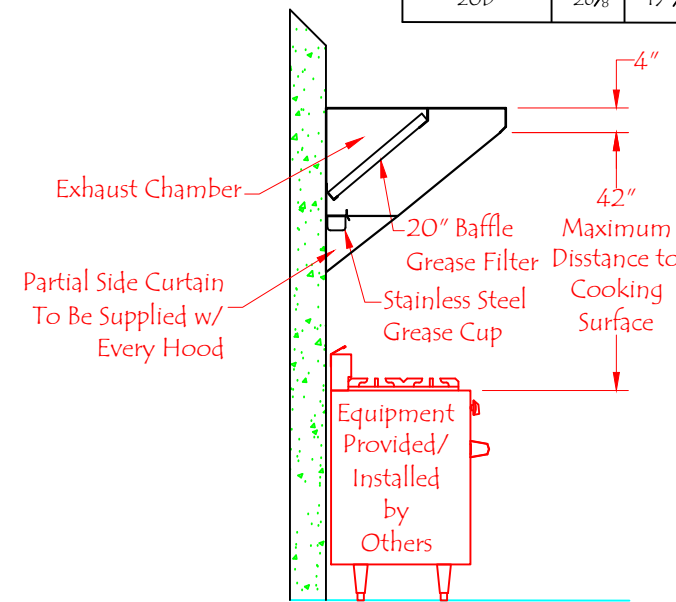

SIDE VIEW
SCALE: 3/8"=1'-0"

*IT IS THE RESPONSIBILITY OF THE ARCHITECT/OWNER TO ENSURE THAT THE HOOD CLEARANCE FROM LIMITED-COMBUSTIBLE MATERIALS IS IN COMPLIANCE WITH LOCAL CODE REQUIREMENTS

ALL EQUIPMENT IS UL LISTED COMPONENTS

HOODMART HOODS ARE BUILT IN COMPLIANCE WITH :
NFPA #96 & UL710

AND ARE RECOGNIZED BY ONE OR MORE OF THE FOLLOWING:
- NSF INTERNATIONAL -UL

HOOD NO.	MODEL	LENGTH	MAX. COOKING TEMP.	① EXHAUST PLENUM					② SUPPLY PLENUM					HOOD CONSTRUCTION			
				TOTAL EXH. CFM	RISER(S)			TOTAL SUP. CFM	RISER(S)								
					WIDTH	LENG.	QTY.	CFM	S.P.		WIDTH	LENG.	QTY.	CFM	S.P.		
1	EXSS011C 11X30	132" NOM 132" OD	700 Deg.	2200	10"	10"	2	1100	.375"	-	-	-	-	-	-	-	STAINLESS STEEL

HOOD NO.	FILTER(S)				LIGHT(S)			UTILITY CABINET(S)				EST. HOOD WEIGHT	
	TYPE	QTY.	HEIGHT	LENGTH	TYPE	QTY.	WIRE GUARD	FIRE SYSTEM		ELECTRICAL MODEL #	SWITCHES		
								TYPE	SIZE		QUANTITY	LOCATION	
1	S.S. BAFFLE W/ HANDLES	2	20"	16"	INCANDESCENT LIGHT	4	NO	--	--	--	--	--	240 LBS.

FAN UNIT NO.	FAN UNIT MODEL #	EXHAUST FAN									SUPPLY FAN									
		MODEL	TAG	CFM	S.P.	RPM	H.P.	Ø	VOLT	FLA	BLOWER	HOUSING	TAG	CFM	S.P.	RPM	H.P.	Ø	VOLT	FLA
1	20D EF-1	20D	EF-1	1100	.375"	1680	1/4	1	115	2.6										
2	20D EF-2	20D	EF-2	1100	.375"	1680	1/4	1	115	2.6										



REVISIONS				
REV.	DATE	DRWN BY	APPR BY	REMARKS
B	8/21/20	TAM	-	CHANGE FAN TYPE AND QTY. ADD DUCT, UPDATE LIGHT QTY.

HOODMART
YOUR ONE STOP HOOD SHOP

172 REASER COURT
ELYRIA, OHIO 44035

TOLL FREE: 1-800-715-1014
FAX: 1-800-716-1214

EQUIPMENT SCHEDULE
CONCESSION CANOPY
CONTRACT NO. - ITEM NO. -
JOB: -
LOC: -
CUST: -
CUST#: -

DWG#11916

SHT -
OF -