

Control Panel V3.01



RECEIVING AND INSPECTION

Upon receiving your equipment, check for any interior or exterior damage. When the truck arrives at your location and the shipment is unloaded, it is **YOUR** responsibility to inspect each and every item for damage **BEFORE** signing the Driver's delivery receipt/Bill of Lading. **DO NOT SIGN until you have thoroughly looked over the equipment.** Once you sign the delivery receipt/Bill of Lading, you relieve the trucking company and North American Kitchen Solutions, Inc. of any and all claims for damaged and/or missing products.

Save these instructions. This document is the property of the owner of the equipment. Leave this document with the owner when installation or service is complete.

WARNING!!

Installation of this equipment should only be performed by a qualified professional. Any alteration to the internal wiring will void warranty and UL 508A listing.

Please read this manual thoroughly before installing or servicing this equipment.

WARNING
Electrical shock hazard. Can cause equipment damage, personal injury, or death. Service must only be performed by personnel that are knowledgeable in the operation of the equipment being controlled.
DANGER
Always disconnect power before working on or near the product. Lock and tag the disconnect switch or breaker to prevent accidental power up.

CAUTION
It is the responsibility of the installer to make sure both electrical and gas appliances shut down in the event of a fire or in the event of a power loss to the building when the sequence is required by the authority having jurisdiction.

INSTALLATION

The equipment is required to be installed and operated as a pre-engineered product, using the equipment which is identified and explained within this manual. If there are any questions about any items, please call the service department at **1-800-715-1014** for warranty and technical support.

WARNING: IMPROPER INSTALLATION, ADJUSTMENT, ALTERATION, SERVICE AND/OR MAINTENANCE CAN CAUSE PROPERTY DAMAGE, INJURY OR DEATH.

PLEASE READ THE INSTALLATION, OPERATION AND MAINTENANCE INSTRUCTIONS BEFORE INSTALLING OR SERVICING THIS EQUIPMENT.



Please be sure to connect the minimum following items to ensure a successful start-up:

- | | |
|---|--|
| <input type="checkbox"/> Main Control Panel Power | <input type="checkbox"/> Power in and out for ALL fans |
| <input type="checkbox"/> BOTH Fire Micro-Switches | <input type="checkbox"/> Exhaust Fan Switch |
| <input type="checkbox"/> Supply Fan Switch | <input type="checkbox"/> Light Switch |
| <input type="checkbox"/> Hood Thermostat(s) | |

RECEIVING/STORAGE

Once equipment is received, check for both obvious and hidden damage. If damage is found, record all necessary information on the bill of lading and file a claim with the final carrier. Check to be sure that all parts of the shipment, including accessories, are accounted for.

If a system must be stored prior to installation it must be protected. Indoor storage is recommended. For outdoor storage, cover the system and accessories with a tarp to keep them clean, dry, and protected from UV (Ultraviolet) radiation damage.

Improper storage which results in damage to the unit will void the warranty.

Site Preparation

1. Make sure that clearance is provided around the installation site to connect Sensors both on the hood and in the room. Note Room Temp/Humidity Sensor to be no closer than 10'-0" to the hood system.
2. When possible, locate unit so that there is at least 24" of clearance in front of the touchscreen to allow adjustment.
3. Review the electrical and project plans and drawings for the job.
4. Determine the exact location of the hood – consult your project plans and drawings. The Hood Temperature Sensors should then be wired back to the Terminal Blocks and should be inspected to verify that there are no interferences which will prevent proper installation.

Follow all local electrical and safety codes, as well as the National Electrical Code (NEC) and the latest edition of the National Fire Protection Agency Standard for Ventilation Control and Fire Protection of Commercial Cooking Operations (NFPA 96). If installing in Canada, follow the Canadian Electrical Code (CEC) and ULC-S650.

Electrical Connections

Before connecting power to the control package, read and understand the entire section of this document. As-built wiring diagrams are furnished with each unit by the factory. They are attached to the control module or provided with paperwork packet, these are the latest documents and should be used to govern field installation of control panels

Electrical wiring and connections must be made in accordance with local ordinances and the National Electric Code, ANSI/NFPA 70. Verify the voltage and phase of the power supply, and the wire amperage capacity is in accordance with the unit nameplate. For additional safety

information, refer to AMCA publication 410-96, Recommended Safety Practices for Users and Installers of Industrial and Commercial Fans.

- Always disconnect power before working on or near this equipment. Lock and tag the disconnect switch and/or breaker to prevent accidental power-up.
- Verify that the power source is compatible with the requirements of your equipment.
 - The nameplate identifies the proper phase and voltage of the equipment.
- Before connecting the unit to the building’s power source, verify that the power source wiring is de-energized.
- Secure the power cable to prevent contact with sharp objects.
- Do not kink power cable and never allow the cable to encounter oil, grease, hot surfaces, or chemicals.
- Before powering up the unit, verify that the fan rotates freely.
 - Check the interior of the unit is free of loose debris or shipping materials.
- If any of the original wire supplied with the unit must be replaced, it must be replaced with type THHN wire or equivalent.

Copper Wire Ampacit

Wire Size AWG	Maximum Amps	Wire Size AWG	Maximum Amps
14	15	4	85
12	20	3	100
10	30	2	115
8	50	1	130
6	65		

High Voltage Wiring

- All high voltage wiring shall be connected to the Terminal Blocks mounted at the top of the control panel. The right side of the control panel should be used for creating access to utilized for high voltage connections.
- Variable Frequency Drives (VFD’s) have screw connectors to the line and load power. The load wiring must not share conduit with other motor load wiring. Each motor must have its own conduit, or the warranty is void.
- There are multiple electrical power sources required for the control panel and hood control wiring. Refer to wiring diagram inside of the panel for details.
- If fire system is present, the fire system micro-switch will need to be wired to terminals as indicated on the installation diagram

Low Voltage Wiring

- Low voltage wiring should be run through the left side of the panel. Do not route low voltage wires on the same side, nor inside of the same conduit as high voltage wiring. Low voltage wiring typically terminates directly on the c.pCO or components.
- Exhaust and Supply fan switch wiring should be connected to terminal block inputs designated on the wiring diagram supplied inside the control panel. 2-wire 18 AWG thermistor cable must be used, and should be connected to individual switches (not provided)
- Temperature Sensor(s) are thermostatically controlled temperature sensor(s) are supplied with wiring compatible for field installation. The temperature sensor(s) should be wired to terminal block inputs designated on the wiring diagram supplied inside the control panel
- Room Temperature/Humidity Sensor for all installations must be installed in a safe location. Locate the sensor so that it is free from external heat sources that may affect the sensor readings. 5-wire 18 AWG thermistor cable must be used.

Variable Frequency Drive (VFD) Installation

Variable Frequency Drives (VFDs) change the speed of 3-phase motors by varying the frequency signal which is sent to the motor. Factory wiring diagrams show which fans are controlled by VFDs.

The load wiring from variable frequency drives must be run in its own conduit. Each motor should not share load wiring conduit with any other motor covered by a variable frequency drive

Input AC Power

- Circuit breakers feeding the VFDs are recommended to be thermal-magnetic and fast-acting.
- Every VFD should be powered by its own breaker. Do not combine multiple VFDs on the same breaker.
- Input AC line wires should be routed in conduit from the breaker panel to the drives. AC input power to multiple VFDs can be run in a single conduit if needed. Do not combine input and output power cables in the same conduit.
- The VFD should be grounded on the terminal marked PE.
- A separate insulated ground wire must be provided to each VFD from the electrical panel. This will reduce the noise being radiated in other equipment.

ATTENTION: Do not connect incoming AC power to output terminals U, V, W. Severe damage to the drive will result. Input power must always be wired to the input L terminal connections (L1, L2, L3).

VFD Output Power

- Motor wires from each VFD MUST be routed in a separate steel conduit away from control wiring and incoming AC power wiring.
- An insulated ground must be run from each VFD to its respective motor.
- Do not install a contactor between the drive and the motor.
- When a disconnect switch is installed between the drive and motor, the disconnect should only be operated when the drive is in a STOP state.

Installation

REFER TO WIRING DIAGRAM FOR SPECIFIC MODEL

Power for Controls

115 VAC, power to controls (Terminal 1, 2, and G)

**BREAKER PANEL TO
PRIMARY CONTROL PANEL**
Responsibility: Electrician
BREAK SIZE SHOWN IS
MAXIMUM ALLOWED

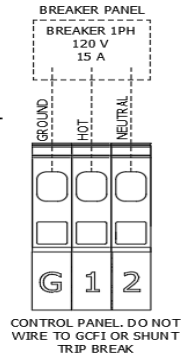

Power for lights/shunt trip (powered from control panel)

115 VAC, power to lights (Terminal 3, 4, and 5) and shunt trip (Terminal 6, 7 and 8)

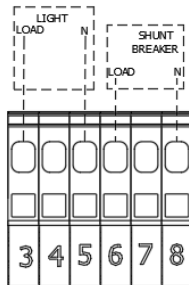

Connection for Exhaust Fan Controls

1351 Figure 1.0

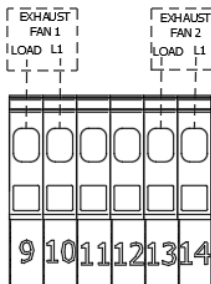

1351 – Figure 1.0

115 VAC, power to controls (Terminal 9) power to fan (Terminal 10)

115 VAC, power to controls (Terminal 13) power to fan (Terminal 14)

1353 Figure 1.1

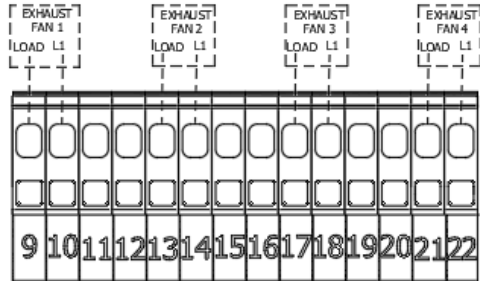

1353 – Figure 1.1

115 VAC, power to controls (Terminal 9) power to fan (Terminal 10)
 115 VAC, power to controls (Terminal 13) power to fan (Terminal 14)
 115 VAC, power to controls (Terminal 17) power to fan (Terminal 18)
 115 VAC, power to controls (Terminal 21) power to fan (Terminal 22)

Connection for Supply Fan Controls

1351 Figure 1.2

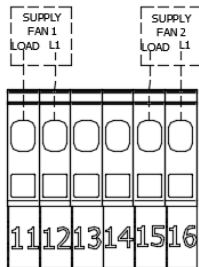

1351 – Figure 1.2

115 VAC, power to controls (Terminal 11) power to fan (Terminal 12)
 115 VAC, power to controls (Terminal 15) power to fan (Terminal 16)

1353 Figure 1.3

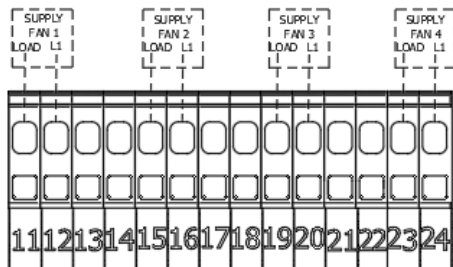

1353 – Figure 1.3

115 VAC, power to controls (Terminal 11) power to fan (Terminal 12)
 115 VAC, power to controls (Terminal 15) power to fan (Terminal 16)
 115 VAC, power to controls (Terminal 19) power to fan (Terminal 20)
 115 VAC, power to controls (Terminal 23) power to fan (Terminal 24)

Signal for Duct Thermostat

1351 Figure 2.0

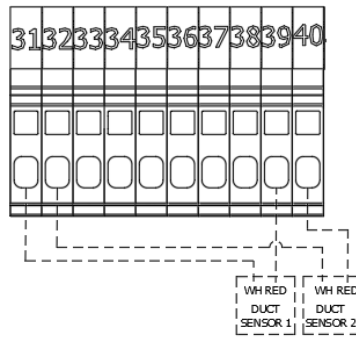

1351 – Figure 2.0

115 VAC, signal power from Duct Thermostat (Mounted on roof of hood) terminals 31 and 39
 115 VAC, signal power from Duct Thermostat (Mounted on roof of hood) terminals 32 and 40

1353 Figure 2.1

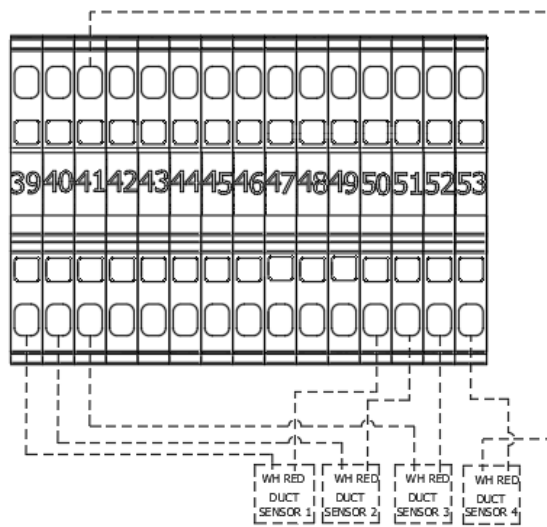

1353 – Figure 2.1

115 VAC, signal power from Duct Thermostat (Mounted on roof of hood) terminals 39 and 50
 115 VAC, signal power from Duct Thermostat (Mounted on roof of hood) terminals 40 and 51
 115 VAC, signal power from Duct Thermostat (Mounted on roof of hood) terminals 41 and 52
 115 VAC, signal power from Duct Thermostat (Mounted on roof of hood) terminals 41 and 53

Connection for Room Temperature/Humidity Sensor

NOTE: WIRE TO CONTROL BOARD. INSTALL SENSOR IN ROOM AWAY FROM HEAT SOURCES. DO NOT INSTALL SENSOR ON CEILING GRID

1351 Figure 3.0

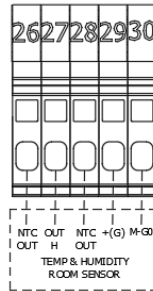

1351 – Figure 3.0

NTC OUT (Terminal 26), OUT H (Terminal 27), NTC OUT(Terminal 28), +(G) (Terminal 29), M-GO(Terminal 30)

1353 Figure 3.1

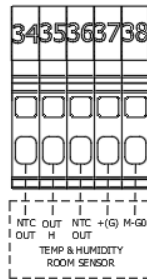

1353 – Figure 3.1

NTC OUT (Terminal 34), OUT H (Terminal 35), NTC OUT(Terminal 36), +(G) (Terminal 37), M-GO(Terminal 38)

Signal for Fire System

Low Voltage 18/2 wire

1351 Figure 4.0

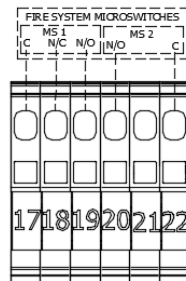

1351 – Figure 4.0

MS1 - Common (Terminal 17), N/C (Terminal 18), N/O (Terminal 19)
MS2 - Common (Terminal 22), N/O (Terminal 20)

1353 Figure 4.1

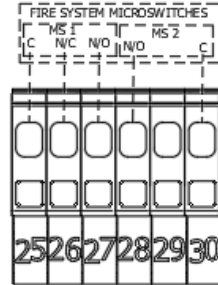

1353 – Figure 4.1

MS1 - Common (Terminal 25), N/C (Terminal 26), N/O (Terminal 27)

MS2 - Common (Terminal 30), N/C (Terminal 28)

Wiring for Fan Switch

Low Voltage 18/2 wire

1351 Figure 5.0

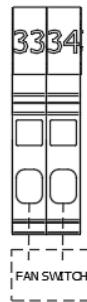

1351 – Figure 5.0

FS - (Terminal 33), (Terminal 34)

1353 Figure 5.1

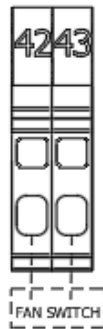

1353 – Figure 5.1

FS - (Terminal 42), (Terminal 43)

Components

Temperature Sensor

(May be loose (Fig. 6.0, Fig. 6.1) or pre-mounted on roof of hood.) The temperature sensor is a 10K ohm thermistor. The sensor gives constant feedback to the control board. One sensor is installed in every exhaust riser for controls packages.

Only a maximum of 5 sensors can be connected to the Terminal Board, normally one room-temperature sensor and then other temperature sensors.

NOTE: NO JUCTION BOX REQUIRED DUE TO INTRINSICALLY SAFE VOLTAGE

Install Hood Temperature Sensor

TYPICAL TEMPERATURE SENSOR LOCATION Figure 6.0

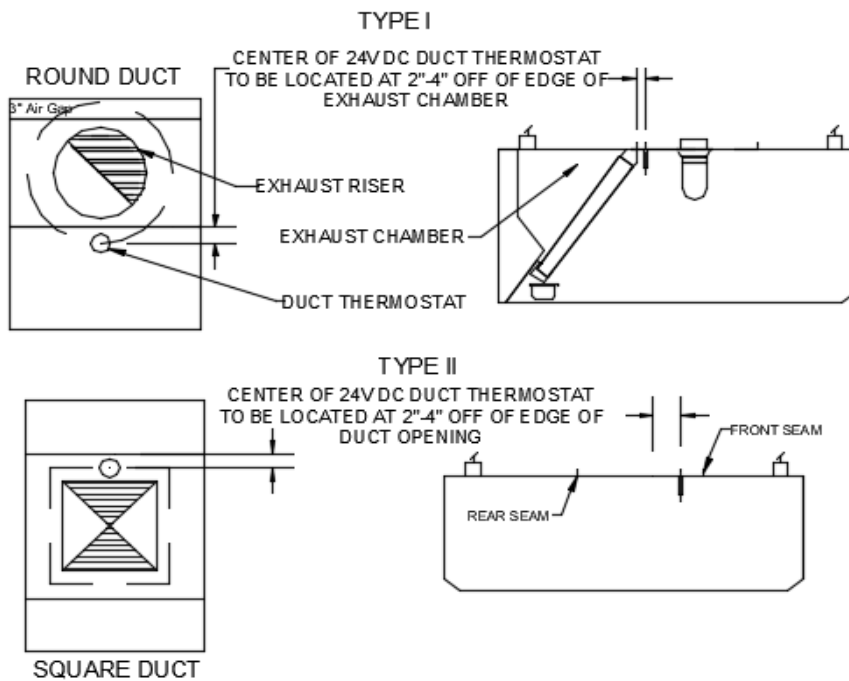

HOOD TEMPERATURE SENSOR INSTALLATION Figure 6.1

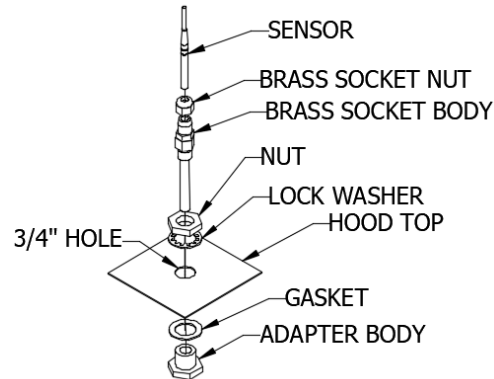

- Drill 3/4" hole in desired location (as determined from above).
- Place gasket on adapter body insert into 3/4" hole
- Add lock washer and nut and tighten
- Screw brass socket body into adapter
- Insert temperature sensor into nickel-coated brass socket
- Tighten nickel-coated brass socket nut around sensor.

Room Temperature/Humidity Sensor

Best mounting locations for the sensor:

- On a wall near a return duct, if possible.
- A location that will provide an accurate representation of the average room temperature/relative humidity/barometric pressure.

ROOM TEMPERATURE SENSOR Figure 6.3

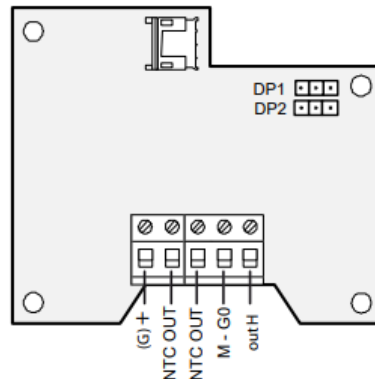

Operation

In the normal operation, all the fans are set to run at 100%.

- This is turned on at 95°F of duct temperature.
- The Hood Exhaust Fans can be controlled by using a remote mounted On/Off switch.
- The Hood Supply Fans can be controlled by using a remote mounted On/Off switch.
- The Hood light can be controlled by remote mounted On/Off switch.

In the fire operation, all the exhaust fans are set to run at 100%.

- This sequence is started by signaling from the fire system microswitches
- Exhaust Fans on
- Supply Fans off
- Lights off
- Shunt trip powered with 120V out

Maintenance:

To ensure proper operation of the control panel, proper maintenance and service should be performed at recommended intervals

WARNING: Do not attempt maintenance on this control until the electrical supply has been completely disconnected.

General Maintenance:

- Keep enclosure clean and free of debris
- All fittings and fasteners should be checked for tightness after maintenance and before start-up
- Control Panel enclosure door should be closed secure prior to energizing the control panel system

Monthly Maintenance:

- Temperature Sensors mounted in hood system should be wiped down to remove any grease or duct build-up with a damp cloth
- All fittings and fasteners should be checked for tightness after maintenance and before start-up

Troubleshooting

Problem	Items to Review	Solutions
Fan(s) rotating incorrect direction	3-Phase motors wired incorrect	Swap 2 of the 3-Phase wires at Load side of cable
		Jumper wires landed incorrectly on VFD
Exhaust Fan not coming on in Fire Mode	Fire microswitches not connected	Check connection to microswitch as per wiring diagram
	VFD not set-up	Review adjustments per manual
Supply Fan not coming shutting down in Fire Mode	Fire microswitches not connected	Check connection to microswitch as per wiring diagram
	VFD not set-up	Review adjustments per manual
Fans not adjusting based on heat	Heat sensors not connected	Check connection from heat sensor to terminals as per wiring diagram
	Check resistance from duct thermostat based on resistance chart	If sensor is found to be more than 5% out of alignment, replace thermostat
120V Shunt trip not powering during Fire Mode	Shunt wiring not connected to terminal block	Check connection to terminal block as per wiring diagram
	Fire microswitches not connected	Check connection to microswitch as per wiring diagram
Lights not coming on under hood system	Fire microswitches not connected	Check connection to microswitch as per wiring diagram
Lights not turning off in fire mode on under hood system	Fire microswitches not connected	Check connection to microswitch as per wiring diagram

Controller IO Table

CONTROLLER'S IO MAPPING				
Main Controller (c.pCO mini)				
Field Device	IO Type	Channel #	Signal Range	Process Range
Z1 Duct Temp. Sens.	Analog Input	U1	NTC	95 - 140 °F
Z2 Duct Temp. Sens.	Analog Input	U2	NTC	95 - 140 °F
Room Temp. Sens.	Analog Input	U3	NTC	65 – 115 °F
Room Hum. Sens.	Analog Input	U4	0-1 Vdc	0 - 100 %
Exhaust 1	Analog Output	U5	0-10 Vdc	CFM
Exhaust 2	Analog Output	U7	0-10 Vdc	CFM
Supply 1	Analog Output	Y1	0-10 Vdc	10 - 100 % Exhaust Fan
Supply 2	Analog Output	Y2	0-10 Vdc	10 - 100 % Exhaust Fan
System On/Off Signal	Digital Output	NO1	0/5 Vdc	Off/On
Hood Light Control	Digital Output	NO2	0/24 Vdc	Off/On
Expansion Controller (c.pCOe mini)				
Field Device	IO Type	Channel #	Signal Range	Process Range
Z3 Duct Temp. Sens.	Analog Input	U1	NTC	95 - 140 °F
Z4 Duct Temp. Sens.	Analog Input	U2	NTC	95 - 140 °F

Duct Thermostat Resistance Table

Table of temperature-resistance values for NTC sensor 10K@25°C B 3435

Temp. °C	Resistance value			Temp. °C	Resistance value			Temp. °C	Resistance value		
	Max. KΩ	Typical KΩ	Min. KΩ		Max. KΩ	Typical KΩ	Min. KΩ		Max. KΩ	Typical KΩ	Min. KΩ
-50	344,60	329,50	314,90	1	26,65	26,13	25,62	56	3,50	3,43	3,35
-49	325,00	310,90	297,30	2	25,52	25,03	24,55	57	3,39	3,32	3,25
-48	306,60	293,50	280,90	3	24,44	23,99	23,54	58	3,28	3,22	3,15
-47	289,40	277,20	265,40	4	23,42	23,00	22,57	59	3,18	3,12	3,05
-46	273,40	262,00	251,00	5	22,45	22,05	21,66	60	3,09	3,02	2,95
-45	258,30	247,70	237,40	6	21,53	21,15	20,78	61	2,99	2,93	2,86
-44	244,20	234,30	224,70	7	20,64	20,30	19,95	62	2,90	2,84	2,77
-43	231,00	221,70	212,80	8	19,81	19,48	19,15	63	2,82	2,75	2,69
-42	218,60	209,90	201,60	9	19,01	18,70	18,39	64	2,73	2,67	2,61
-41	207,00	198,90	191,00	10	18,25	17,96	17,67	65	2,65	2,59	2,53
-40	196,00	188,50	181,10	11	17,51	17,24	16,97	66	2,57	2,51	2,45
-39	185,50	178,50	171,60	12	16,81	16,56	16,30	67	2,50	2,44	2,38
-38	175,60	169,00	162,60	13	16,14	15,90	15,67	68	2,42	2,36	2,31
-37	166,30	160,20	154,20	14	15,50	15,28	15,06	69	2,35	2,30	2,24
-36	157,60	151,90	146,30	15	14,89	14,69	14,48	70	2,28	2,23	2,17
-35	149,40	144,10	138,80	16	14,31	14,12	13,92	71	2,22	2,16	2,11
-34	141,70	136,70	131,80	17	13,75	13,58	13,39	72	2,15	2,10	2,05
-33	134,50	129,80	125,20	18	13,22	13,06	12,89	73	2,09	2,04	1,99
-32	127,70	123,30	119,00	19	12,72	12,56	12,40	74	2,03	1,98	1,93
-31	121,20	117,10	113,10	20	12,24	12,09	11,94	75	1,98	1,92	1,87
-30	115,20	111,30	107,50	21	11,77	11,63	11,50	76	1,92	1,87	1,82
-29	109,40	105,70	102,20	22	11,32	11,20	11,07	77	1,87	1,82	1,77
-28	103,90	100,50	97,20	23	10,90	10,78	10,66	78	1,81	1,77	1,72
-27	98,68	95,52	92,45	24	10,49	10,38	10,27	79	1,76	1,72	1,67
-26	93,80	90,84	87,97	25	10,10	10,00	9,90	80	1,72	1,67	1,62
-25	89,20	86,43	83,73	26	9,73	9,63	9,53	81	1,67	1,62	1,58
-24	84,85	82,26	79,74	27	9,38	9,28	9,18	82	1,62	1,58	1,53
-23	80,76	78,33	75,96	28	9,04	8,94	8,84	83	1,58	1,53	1,49
-22	76,89	74,61	72,39	29	8,72	8,62	8,52	84	1,54	1,49	1,45
-21	73,23	71,10	69,01	30	8,41	8,31	8,21	85	1,49	1,45	1,41
-20	69,77	67,77	65,82	31	8,11	8,01	7,92	86	1,45	1,41	1,37
-19	66,44	64,57	62,74	32	7,83	7,73	7,63	87	1,42	1,37	1,33
-18	63,30	61,54	59,83	33	7,55	7,45	7,36	88	1,38	1,34	1,30
-17	60,32	58,68	57,07	34	7,29	7,19	7,10	89	1,34	1,30	1,26
-16	57,51	55,97	54,46	35	7,04	6,94	6,85	90	1,31	1,27	1,23
-15	54,85	53,41	51,99	36	6,79	6,70	6,61	91	1,27	1,23	1,19
-14	52,33	50,98	49,65	37	6,56	6,47	6,37	92	1,24	1,20	1,16
-13	49,95	48,68	47,43	38	6,34	6,25	6,15	93	1,21	1,17	1,13
-12	47,69	46,50	45,32	39	6,12	6,03	5,94	94	1,17	1,14	1,10
-11	45,55	44,43	43,33	40	5,92	5,83	5,74	95	1,14	1,11	1,07
-10	43,52	42,47	41,43	41	5,72	5,63	5,54	96	1,12	1,08	1,04
-9	41,55	40,57	39,60	42	5,53	5,44	5,35	97	1,09	1,05	1,02
-8	39,69	38,77	37,86	43	5,34	5,26	5,17	98	1,06	1,02	0,99
-7	37,92	37,06	36,21	44	5,17	5,08	4,99	99	1,03	1,00	0,97
-6	36,25	35,44	34,64	45	5,00	4,91	4,83	100	1,01	0,97	0,94
-5	34,66	33,90	33,15	46	4,83	4,75	4,67	101	0,98	0,95	0,92
-4	33,15	32,44	31,73	47	4,68	4,59	4,51	102	0,96	0,92	0,89
-3	31,72	31,05	30,39	48	4,52	4,44	4,36	103	0,93	0,90	0,87
-2	30,36	29,73	29,11	49	4,38	4,30	4,22	104	0,91	0,88	0,85
-1	29,06	28,48	27,89	50	4,24	4,16	4,08	105	0,89	0,86	0,83
0	27,83	27,28	26,74	51	4,10	4,03	3,95	106	0,87	0,84	0,81
				52	3,97	3,90	3,82	107	0,84	0,82	0,79
				53	3,85	3,77	3,70	108	0,82	0,80	0,77
				54	3,73	3,65	3,58	109	0,80	0,78	0,75
				55	3,61	3,54	3,46	110	0,79	0,76	0,73

TERMS AND CONDITIONS OF SALE

THESE TERMS AND CONDITIONS OF SALE (“*TERMS*”) CONTAIN VERY IMPORTANT INFORMATION REGARDING YOUR PURCHASE, AS WELL AS CONDITIONS, LIMITATIONS, AND EXCLUSIONS THAT APPLY TO YOU AND YOUR PURCHASE. PLEASE READ THEM CAREFULLY. YOUR PURCHASE IS EXPRESSLY LIMITED TO AND MADE CONDITIONAL UPON THE EXCLUSIVITY OF THESE TERMS. ANY PROPOSAL FOR DIFFERENT TERMS OR ANY ATTEMPT TO VARY, IN ANY DEGREE, ANY OF THESE TERMS IS EXPRESSLY REJECTED.

1. **Acceptance.** These Terms govern any purchase made from North American Kitchen Solutions, Inc. (“*North American Kitchen Solutions*”). These Terms, the Manual in which they are contained, installation and maintenance instructions, the applicable invoice, and any documents incorporated or referred to herein or therein, including any future paper or electronic releases issued by North American Kitchen Solutions, constitute the “Order.” The Order is the entire contract between you, the buyer, and North American Kitchen Solutions, the seller, for products purchased from North American Kitchen Solutions. These Terms apply to the Order unless expressly modified or waived in writing by an officer of North American Kitchen Solutions. An Order may only be cancelled by you upon payment of reasonable cancellation charges for expenses incurred or commitments made by North American Kitchen Solutions. Captions in these Terms are for convenience only.

2. **Pricing.** The price for North American Kitchen Solutions' goods, material, equipment, or items (“*Products*”) is complete, and no deductions, credits, or offsets may be made without North American Kitchen Solutions' express written consent. Prices are subject to change and surcharges in the event of cost increases in materials and transportation. All complete component accessory material manufactured by others and furnished with Products such as motors, drives, vibration equipment, controls, or other completely assembled component structures, are subject to adjustment to the price at time of shipment regardless of the date of original order entry.

3. **Sales and Similar Taxes.** North American Kitchen Solutions' prices do not include sales, use, excise, or similar taxes. Present or future sales, use, excise, or other similar tax applicable to the sale of Products shall be paid you, unless an acceptable tax exemption certificate is provided to North American Kitchen Solutions.

4. **Payment.** North American Kitchen Solutions reserves the right to require full or partial payment in advance of any order. Pro rata payments are due as shipments are made. Each shipment or delivery shall constitute a separate sale, and the default of any shipment or delivery shall constitute a separate sale, and the default of any shipment or delivery shall not vitiate the contract as to other shipments or deliveries.

5. **Delivery.** Shipping and delivery dates are estimates only. No delay in delivery will subject North American Kitchen Solutions to any costs, damages, or fees for late delivery. Delivery of Products is made F.O.B. point of shipment, unless otherwise stated. North American Kitchen Solutions shall not be liable for delay due to causes beyond its reasonable control (i.e., force majeure events). In the event of such a delay, the date of delivery shall be extended for a period equal to the time lost by reason of the delay.

6. **Changes.** North American Kitchen Solutions may make changes, including improvements and additions, in the technical requirements, specifications, designs, materials, packaging, and place of delivery, method of transportation, quantities, or delivery schedules of the Products by notifying you.

7. **Safety.** The Products may be designed to serve multiple applications. North American Kitchen Solutions offers a range of safety equipment, including guards and other devices, as may be required to

meet customer specifications. Without exception, North American Kitchen Solutions recommends that all orders include applicable safety devices. Use of Products ordered without applicable safety devices are your sole responsibility. You warrant that you have determined and acquired any and all safety devices required for the Products. Weather covers and guards for motor and V-belt drives, couplings, shafts and bearings, along with inlet and outlet screens, are optional accessories noted in the price list.

8. **Title.** Title and right of possession of Products remains with North American Kitchen Solutions until all payments (including deferred payments whether evidenced by notes or otherwise) shall have been received to the satisfaction of North American Kitchen Solutions and you agree to do all acts necessary to perfect and maintain such title and right in North American Kitchen Solutions and not to subject any Products to any liens or encumbrances until such payment is made in full.

9. **Governing Law.** This Order shall be governed by and construed according to the laws of the State of Ohio (excluding the conflict of law provisions thereof). At North American Kitchen Solutions' discretion, any action relating directly or indirectly to the Order shall be brought exclusively in the Common Pleas Court of Cuyahoga County, Ohio or the United States District Court for the Northern District of Ohio, Eastern Division, and you irrevocably waive any objection to the jurisdiction of, or venue in, either of these courts and agree that the acceptance of the Order constitutes doing business in the State of Ohio.

10. **Arbitration.** At North American Kitchen Solutions' discretion, any dispute arising under or in connection with any Order may be submitted to binding arbitration administered by the American Arbitration Association under its Commercial Arbitration Rules, and judgment on the award rendered by the arbitrator may be entered in any court having jurisdiction thereof. The dispute shall be resolved by one neutral arbitrator who shall have no affiliation with either you as the buyer or with North American Kitchen Solutions and shall be selected by the American Arbitration Association office, and held in, Cleveland, Ohio.

WARNING. North American Kitchen Solutions' Products are designed and manufactured to provide reliable performance, but they are not guaranteed to be 100% free of defects. Even reliable products will experience occasional failures and this possibility should be recognized by the buyer and all end users. If Products are used in life support ventilation systems where failure could result in loss or injury, the buyer and all end users should provide adequate backup ventilation, supplementary natural ventilation, or failure alarm system, or acknowledge willingness to accept the risk of such loss or injury. **DO NOT USE IN HAZARDOUS ENVIRONMENTS** where a fan's electrical system could provide ignition to combustible or flammable materials unless unit is specifically built for hazardous environments. Comply with all local and national safety codes including the National Electrical Code (NEC) and National Fire Protection Act (NFPA).

CAUTION. Guards must be installed when fan is within reach of personnel or within eight (8) feet (2.5 m) of working level or when deemed advisable for safety.

DISCLAIMER. North American Kitchen Solutions has made a diligent effort to illustrate and describe the Products accurately in all materials; however, such illustrations and descriptions are for the sole purpose of identification and do not express or imply any warranty.

LIMITED WARRANTY

WARRANTY AND DISCLAIMER. This limited warranty extends to you the original purchaser only with proof of purchase. NAKS warrants that Products shall be free from original defects in workmanship and materials for two years from date of shipment (except for the warranty periods noted for products listed below), provided the Products have been properly handled, stored, installed, serviced, maintained and operated. This warranty shall not apply to Products which have been altered or repaired without NAKS' express authorization, or altered or repaired in any way so as, in NAKS' judgment, to affect performance or reliability, nor which have been improperly installed or subjected to misuse, negligence, or accident, or incorrectly used in combination with other substances. You assume all risks and liability for results of use of all Products.

Evaporative cooling pads are warranted to be free of defects in materials and workmanship for a period of two years from date of shipment provided same have been properly handled, stored, installed, serviced, maintained and operated; and further, not subjected to excessive heat, corrosive agents or chemicals, or mechanical abuse that may cause tearing, crushing or undue deterioration, nor used on a system or in a manner other than that for which it was designed as explained in the Order.

LIMITATION OF REMEDY AND DAMAGES. All claims under this warranty must be made in writing and delivered by U.S. Mail to:

North American Kitchen Solutions, Inc.
172 Reaser Court
Elyria, OH 44035
Attn: WARRANTY CLAIMS DEPARTMENT

All Product claims must be made within 15 days after discovery of the defect and prior to the expiration of two years from the date of shipment. Claims made beyond that period are barred. Within 30 days after receipt of a timely claim, NAKS shall have the option either to inspect the Product at its location or request its return to NAKS at your expense. NAKS shall replace, or at its option repair, free of charge, any Product it determines to be defective, and it shall ship the repaired or replacement product to you F.O.B. point of shipment; provided, however, if in NAKS' judgment circumstances are such to prohibit repair or replacement to remedy the warranted defects, your sole and exclusive remedy shall be a refund of any part of the invoice price, paid to NAKS, for the defective Product or part.

NAKS is not responsible for the cost of removal of the defective Product or part, damages due to removal, or any expenses incurred in shipping the Product, or the installation of the repaired or replaced Product or part.

The warranties set forth above do not apply to any components, accessories, parts or attachments manufactured by other manufacturers; such being subject to the

manufacturer's warranty, if any. To the extent not prohibited by the manufacturer's warranty, NAKS shall pass to you such manufacturer's warranty.

THIS WARRANTY IS IN LIEU OF ALL OTHER WARRANTIES, EXPRESS OR IMPLIED, ARISING BY LAW OR OTHERWISE, INCLUDING WITHOUT LIMITATION THE IMPLIED WARRANTIES OF MERCHANTABILITY AND FITNESS FOR A PARTICULAR PURPOSE, WHICH ARE HEREBY EXPRESSLY DISCLAIMED AND WAIVED. THIS WARRANTY CONSTITUTES NAKS SOLE AND EXCLUSIVE WARRANTY FOR DEFECTIVE GOODS AND PURCHASER'S SOLE AND EXCLUSIVE REMEDY FOR DEFECTIVE PRODUCTS.

No employee, agent, dealer, or other person is authorized to give any warranties on behalf of NAKS or to assume for it any other liability in connection with any of its products except in writing and signed by an officer of NAKS.

LIMITATION OF LIABILITY. NAKS' cumulative liability to you and any other persons for all claims in any way relating to or arising out of the Products, including, but not limited to, any cause of action sounding in contract, tort, or strict liability, shall not exceed the total amount of the purchase price paid for those Products which are the subject of any such claim. This limitation of liability is intended to apply without regard to whether other provisions of this agreement have been breached or have proven ineffective even if NAKS has been advised of the possibility of such claims or demands. In no event shall NAKS be liable to you or any other person for any loss of profits or any incidental, special, exemplary, or consequential damages for any claims or demands brought by you or such other persons. BECAUSE SOME JURISDICTIONS DO NOT ALLOW THE EXCLUSION OR LIMITATION OF LIABILITY FOR CONSEQUENTIAL OR INCIDENTAL DAMAGES, THIS LIMITATION MAY NOT APPLY TO YOU.

NAKS' maximum liability to you and to any end user is as set forth above. NAKS makes no warranty to anyone for any products not manufactured by it and shall have no liability for any use or installation of any products (whether manufactured by NAKS or other manufacturers) not specifically authorized by this sale. You acknowledge various warnings by NAKS regarding the Products and their installation and use. If NAKS incurs any claims, lawsuits, settlements, or expenses (including attorney fees) for any loss, injury, death or property damage including, but not limited to, claims arising out of your or any end user's installation or use of the Products, you agree to indemnify and hold NAKS harmless.

REPLACEMENT PARTS. If replacement parts are ordered, purchaser warrants that the original components in which these replacement parts will be placed are in satisfactory working condition, and when said replacement parts are installed, the resultant installation will operate in a safe manner, at speeds and temperatures for which the original product was purchased.

TECHNICAL ADVICE AND RECOMMENDATIONS, DISCLAIMER. Notwithstanding any past practice or dealings or any custom of the trade, sales shall not include the furnishing of technical advice or assistance or system design. Any such assistance shall be at NAKS' sole option and may be subject to additional charge(s).

NAKS assumes no obligation or liability on account of any recommendations, opinions, or advice as to the choice, installation or use of Products. Any such recommendations, opinions or advice are given and shall be accepted at your and the end-user's risk and shall not constitute any warranty or guarantee of such Products or their performance.

2022 © North American Kitchen Solutions, Inc. • 172 Reaser Court, Elyria, OH 44035

Toll Free: (800) 715-1014

customerservice@naksinc.com