

**MODEL# 85BS**

**UL762 UPBLAST EXHAUST FAN  
BELT DRIVE**

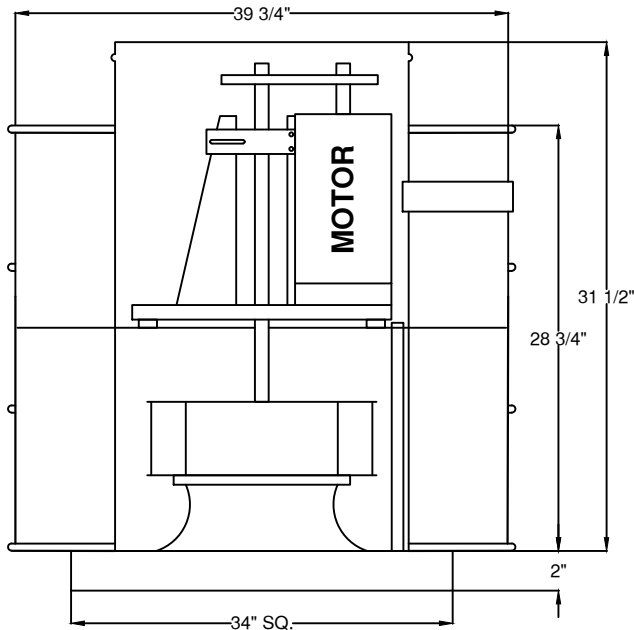

**DIMENSIONAL DATA**  
32 1/2" SQ. CURB

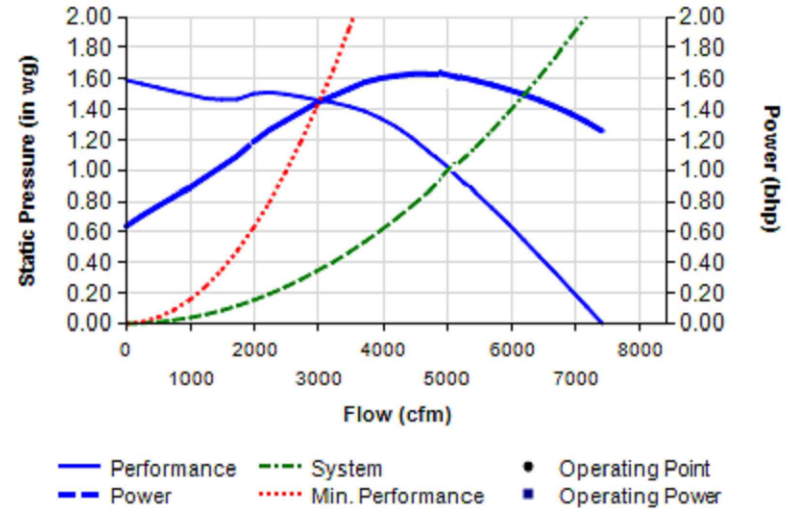

**PERFORMANCE DATA**

PHASE	1	VOLTS	115/230
AMPS	20.4/10.2	HP	2

RPM	.000" S.P.		.250" S.P.		.50" S.P.		.75" S.P.		1.000" S.P.		1.25" S.P.		1.50" S.P.		1.75" S.P.	
	CFM	Sone	CFM	Sone	CFM	Sone	CFM	Sone	CFM	Sone	CFM	Sone	CFM	Sone	CFM	Sone
725	5890	16.6	5188	15.3	4446	13.8	3588	12.7	-	-	-	-	-	-	-	-
913	7417	23	6863	21	6297	19.8	5706	18.6	5060	17.5	4290	16.6	-	-	-	-
1005	8164	25	7661	24	7151	23	6632	22	6074	21	5471	19.9	4779	18	3459	18.8

**STANDARD FEATURES**

- HEAVY GAUGE ALUMINUM HOUSING
- 1 YEAR LIMITED WARRANTY ON ALL ELECTRIC MOTORS
- FACTORY SET DRIVE
- BELT DRIVEN MOTORS ARE ENCLOSED IN WEATHER-TIGHT COMPARTMENTS
- AVERAGE UNIT WEIGHT: 198 LBS
- AVERAGE SHIPPING WEIGHT: 325 LBS
- MEETS 2009 IBC:SEISMIC



**LISTED**

FANS

**UL 762**

14027 1/20