

MODEL # SF-AGV3400

GRAVITY RELIEF VENTILATOR

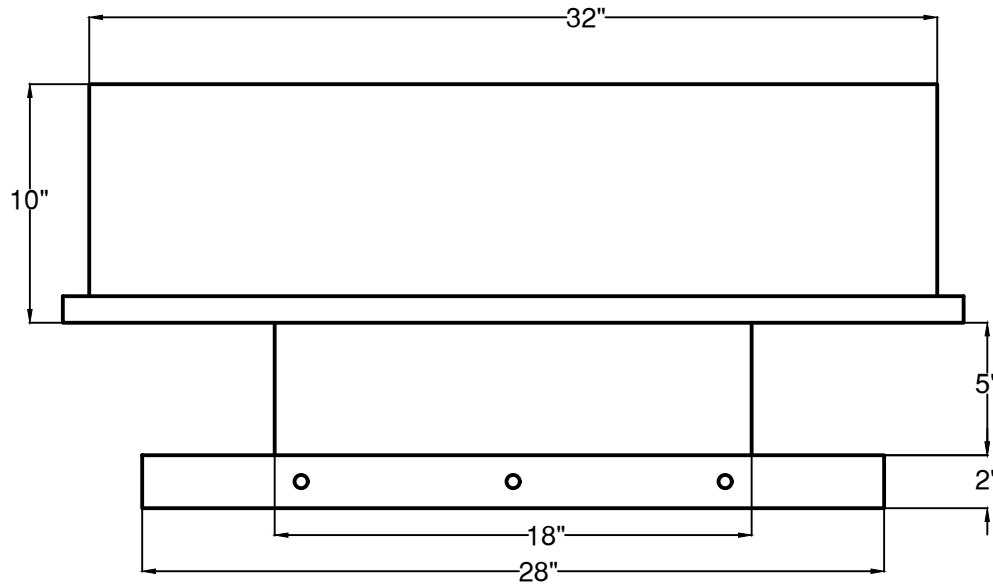

DIMENSIONAL DATA
26 1/2" ROUGH OPENING

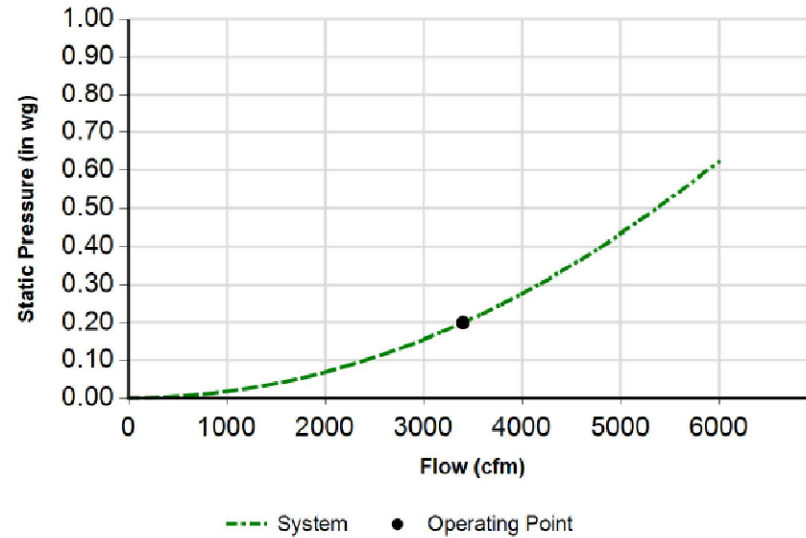

PERFORMANCE DATA

VOLUME	3400	S.P.	.200"
---------------	------	-------------	-------

STANDARD FEATURES

- .050" GALVANIZED STEEL MESH BIRDSCREEN
- GALVANIZED CONSTRUCTION DESIGN IS 18 GA. BASE AND STRUCTURE AND 20 GA. HOOD AND ENDS
- LOW SILHOUETTE DESIGN
- 2 YEAR LIMITED WARRANTY
- AVERAGE UNIT WEIGHT: 90 LBS
- AVERAGE SHIPPING WEIGHT: 98 LBS