



Read and Save These Instructions

INSTALLATION & MAINTENANCE INSTRUCTIONS

Direct Drive Restaurant Grease Rated Fans

RECEIVING AND INSPECTION

Immediately upon receipt of a shipment, carefully inspect for damage and shortage. Turn impeller by hand to see that it turns freely and does not bind. If any damage and/or shortage is detected or suspected, the carrier must be asked to conduct an inspection. The consignee's representative should not accept shipment without a notation on the delivery receipt indicating items not delivered or apparent extent of damage.

When a shipment is opened and damage is found which was not evident externally (concealed damage), it is mandatory that the consignee request an immediate inspection by the carrier. Report damage to the carrier within 15 days. Failure to report damage within the above time limit will cause rejection of a claim.

HANDLING

When handling fans and their accessories, always use equipment and methods that will not cause damage. Fans should be lifted using slings and padding or spreaders to avoid damage.

CAUTION! Always make sure that all lifting and handling equipment and techniques conform to current safety standards.

Avoid lifting fans in a way that will bend or distort fan parts. Never pass slings or timbers through the orifices of fan.

CAUTION! Do not lift by the fan hood. Fans with special coatings or paints must be protected in handling to prevent damage.

STORAGE

Fans are protected against damage during shipment. If they cannot be installed and put into operation immediately upon receipt certain precautions are necessary to prevent deterioration during storage. Responsibility for integrity of fans and accessories during storage must be assumed by the user. The manufacturer will not be responsible for damage during storage. These suggestions are provided solely as a convenience to the user, who shall make his own decision as to whether to use any or all of them.

INDOOR: The ideal storage environment for fans and accessories is indoors, above grade, in a low humidity atmosphere which is sealed to prevent the entry of blowing dust, rain, or snow. Temperatures should be evenly maintained at between 70°F and 105°F (wide temperature swings may cause condensation and "sweating" of metal parts). Windows should be covered to prevent temperature variations caused by sunlight. Provide thermometers and humidity indicators at several points and maintain the atmosphere at 40% relative humidity, or lower.

It may be necessary to use trays of renewable desiccant or portable dehumidifier to remove moisture from the air in the storage enclosure.

Thermostatically controlled portable heaters (vented to outdoors) may be required to maintain even temperatures inside the enclosure.

CAUTION! Provide fire extinguishers, or fire alarms, or emergency response communication to protect building and equipment against fire damage. Be sure that building and storage practices meet all local, state and federal fire and safety codes.

The following fans or accessories must be stored indoors, in a clean dry atmosphere:

- a. Any fan that is protected by a cardboard carton.
- b. Spare wheels or propellers.
- c. Boxes, bags or cartons of hardware.
- d. Curbs
- e. Dampers

Remove any accumulations of dirt, water, ice or snow and wipe dry before moving indoor storage. Allow cold parts to reach room temperature to avoid "sweating" of metal parts. Open boxes or cartons. Remove any accumulated moisture; if necessary use portable electric heaters to dry parts and packages. Leave coverings loose to permit air circulation and to permit periodic inspection.

Rotate wheels or propellers by hand to distribute bearing grease over the entire bearing surfaces.

Store at least 3 ½" off the floor on wooden blocks covered with moisture proof paper or polyethylene sheathing. Provide aisles between parts and along all walls, to permit air circulation and space for inspection.

OUTDOOR: Fans designed for outdoor use may be stored outdoors, if absolutely necessary. The storage area should be reasonably level and drained or ditched to prevent accumulation of water. Fencing and lighting for security are desirable. Roads or aisles for portable cranes and hauling equipment are needed. Consider the use of drift fencing to minimize accumulation of blowing snow or dirt.

The following fans may be stored outdoors, if dry indoor storage space is not available:

- a. Fans intended for outdoor use that are crated in wood.
- b. Wall fans installed in wall housings.

All fans must be supported on wooden blocks or timbers above water or normal snow levels. Provide enough blocking to prevent settling into soft ground. Fans should be set in place using the directional arrow markings on the crate as a guide.

Locate pieces far enough apart to permit air circulation, sunlight, and space for periodic inspection. Place all parts on their supports so that rain water will run off, or to minimize water accumulation. Do not cover parts with plastic film or tarps—these cause condensation of moisture from the air passing through heating and cooling cycles.

Fan wheels and propellers should be blocked to prevent spinning caused by strong winds.

INSPECTION AND MAINTENANCE DURING STORAGE

Inspect fans and accessories at least once per month, while in storage. Log results of inspection and maintenance performed. A typical log entry should include the following:

- a. Date
- b. Inspector's Name
- c. Name of Fan
- d. Location
- e. Condition of Paint or Coating
- f. Is moisture present?
- g. Is dirt accumulated?
- h. Corrective steps taken?

If moisture or dirt accumulations are found on parts, the source should be located and eliminated. Fans should be rotated at each inspection by hand ten to fifteen revolutions to redistribute the motor and bearing lubricant.

If paint deterioration begins, consideration should be given to touch-up or repainting. Fans with special coatings may require special techniques for touch-up or repair.

Machined parts coated with rust preventive should be restored to good condition promptly if signs of rust occur. The most critical items are pulleys, shafts and bearing locking collars. At the first sign of rusting on any of the above parts, remove the original rust preventive coating with petroleum solvent and clean lint-free cloths. Polish any remaining rust from surfaces with crocus cloth or fine emery paper and oil. Do not destroy the continuity of the surfaces. Wipe clean with lint-free cloths and recoat surfaces evenly and thoroughly with Tectyl 506 (Daubert Chemical Company) or equal. For hard to reach internal surfaces or for occasional use, consider using Tectyl 511M Rust Preventive or WD40 or equal.

REMOVING FROM STORAGE

As fans are removed from storage to be installed in their final location, they should be protected and maintained in similar fashion, until the fan equipment goes into operation.

BEFORE INSTALLING CHECK FASTENERS

Before installing and before initial operations of the fan tighten all mounting hardware and set screws. Verify wheel turns freely. See table recommended tightening torque located in Maintenance Section..

INSTALLATION

1. **CAUTION!** This unit has rotating parts and safety precautions should be exercised during installation, operation and maintenance.
2. **WARNING! If gases, other than clean air, are to be exhausted using the fan, then the user bears the responsibility of determining that the fan is appropriate and safe for the application.**
3. **WARNING! Do not** use in hazardous environments where the fan's electrical system could provide ignition to combustible or flammable materials, unless unit is built specifically for the environment.
4. **COMMERCIAL KITCHEN EXHAUST APPLICATIONS**

Ventilators should be installed in accordance with the requirements of the National Fire Protection Association Bulletin NFPA96 "Vapor Removal From Cooking Equipment" taking specific note of the following:

- a. Ducts terminating into the base of an up-discharge exhaust fan must be constructed of carbon steel not less than 16MSG (67.47 mm) and extend a minimum of 18" (457 mm) above the roof surface.
- b. Air velocity through the duct not less than 1500 FPM (7.620 m/s).
- c. A minimum of 40" (1016 mm) clearance be maintained between the exhaust discharge and any roof surface. (To comply, size 80 to 135 require 24" [610 mm] roof curb. Size 150 to 200 require 18" [457 mm] roof curb.)

5. FAN INSTALLATION:

WALL MOUNT: If wall mounted, provide an opening sufficient for enclosing the curb cap. Securely fasten to the wall through the cap. Fan breather tube should be on the

side of the fan at a 90° angle from vertical. A wall mounting adapter option is available from the manufacturer. On wall mounted models the wall bracket is shipped with the fan.

ROOF MOUNT: Roof exhausters should be mounted on a roof curb suitable for the purpose, either field fabricated or prefab type. (Prefab type available as an accessory at extra cost.) The fan should rest on the curb as level as possible. When curb is not level (slightly pitched on flat roofs) the down spout drain fitting should be located on lowest side of curb. Securely fasten exhauster to curb using a minimum of 4 lag bolts - one centered each side.

6. **CAUTION!** Guards must be installed when fan is within reach of personnel or within eight (8) feet (2.5 m) of working level or when deemed advisable for safety.
7. **IMPELLER-ORIFICE ADJUSTMENT:** Turn centrifugal impeller by hand to make sure it rotates freely. If impeller hits inlet orifice, adjust as follows: Loosen four (4) nuts inside motor enclosure. Adjust motor laterally to equalize clearance on all sides of impeller. Tighten four (4) nuts.
8. **ELECTRICAL CAUTION:** Before proceeding, make sure electrical service to fan is locked in "OFF" position. Run wires through the internal wiring post to the motor, to safety disconnect switch if used. (Restaurant exhaust fans have wires through breather tube.)
9. All wiring should be in accordance with local ordinances and the National Electric Code.

**FOR EC MOTOR WIRING REFER TO EC
MOTORING WIRING SECTION**

10. **BEFORE APPLYING POWER** Check all fasteners for tightness, particularly in the impeller hub. Turn impeller by hand to make sure it is in alignment with the orifice and fan blades do not strike.
11. **WARNING!** Check voltage at the fan to see if it corresponds with the motor nameplate. High or low voltage can seriously damage the motor. Extra care should be taken when wiring to two or three speed motors since improper connections will damage motor and void motor warranty.
12. Apply power momentarily and compare the rotation of the impeller with the directional arrow on fan. **WHEEL ROTATION IS CLOCKWISE AS VIEWED FROM TOP OF FAN. WARNING!** Do not operate at speeds higher than shown in catalog for this equipment. Operation in the wrong direction will deliver air but will overload the motor to the extent of blowing fuses, or overload protection and could seriously damage the motor. In the case of three phase motors, the direction can be changed by interchanging any two of the three motor leads. In the case of single phase motors, the reversing instructions will appear on the wiring diagram in the motor wiring compartment or on the motor.
13. **GREASE TROUGHS AND CURB HINGES** are available as optional accessories. Installation instructions are shipped with the accessories.

NOTE: The controller must be powered up before or at the same time as power is supplied to the motor.

Mounted Speed Dial** (Figure 1) – The Perfect Speed control box interface allows direct control of the motor by turning the onboard speed dial located to the right of the digital display.

Optional Speed Controller (See Figure 2)

Remote Speed Dial** – (See Figure 2 and 2A) When selected with this option the fan will come with a control cable and quick connect Molex plug that can be plugged into the Molex plug on the single speed potentiometer box***. Set blue speed dial on PerfectSpeed controller to zero (turn left). Speed B on box is not used for single speed selection and will not have a dial. The motor will shut off between 0-1.9V.

Two Speed Dial** – (See Figure 2 & 2B) When selected with this option the fan will come with a control cable and quick connect Molex plug that can be plugged into the Molex plug on dual speed dial. The supplied un-mounted toggle switch will select the Low (LO) or High (HI) speed on the speed controllers based on the dial settings. The motor will shut off between 0-1.9v.

Building Control 0-10VDC Wire Kit (See Figure 2 & 2C) Factory mounted Molex receptacle that allows a quick connection to supplied 2 wire connector (wires are 3" long).

NOTE: FOR OPTIONAL SPEED CONTROL SET THE BLUE SPEED DIAL TO 0%.

More information on US Motors perfect speed interface can be found at: <http://www.usmotors.com/Our-Products/ECM-Motors>

** Disconnects and Speed Dials are available as mounted on certain fan models and will be wired to motor as shown in Figure 10 for more information see descriptions on submittals for these items weather they are mounted, not mounted or not available.

*** For extended wiring up to 100 Feet you will need (1) Receptacle Molex 3 1396-R4 with 3 Pin Female Molex 02-09-1119 and (1) Plug Molex 3 Pin 1396-P1 with Pin Male Molex 02-09-2118 not provided.

FIGURE 1 Mounted Speed Dial

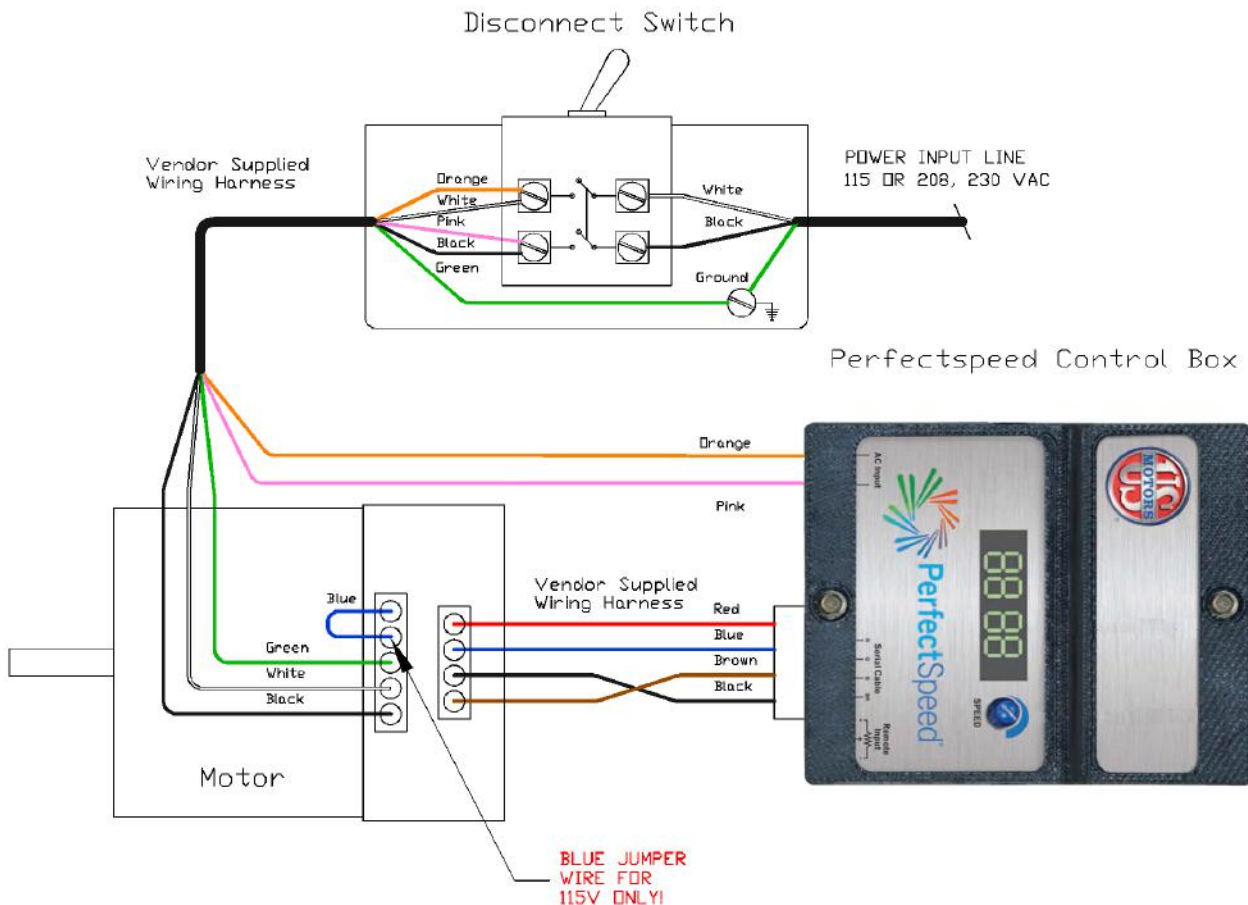

FIGURE 2

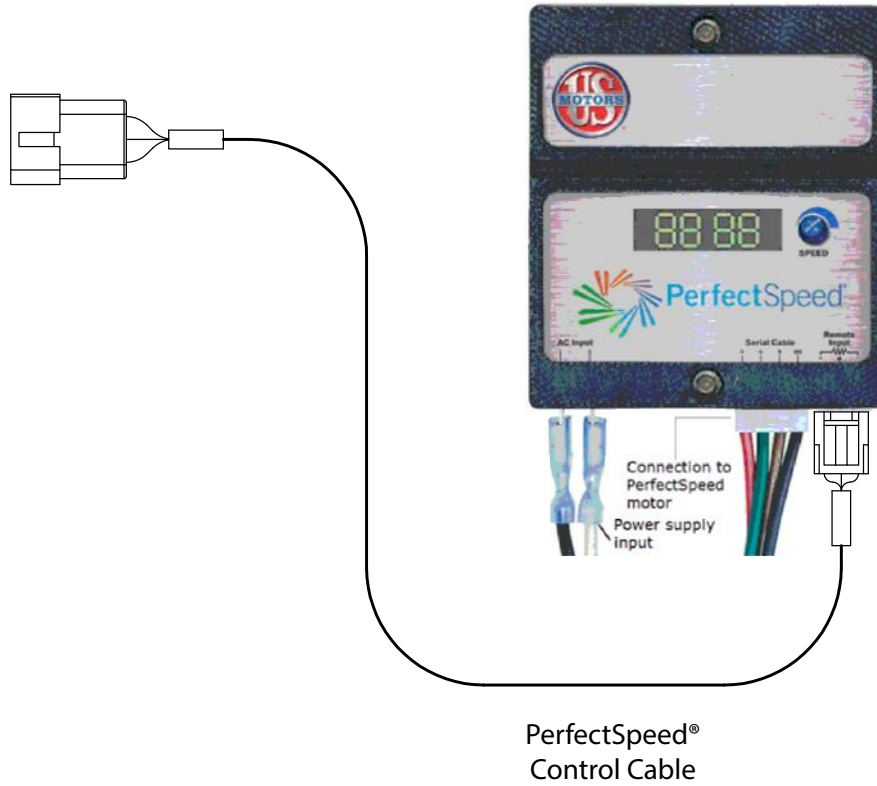

FIGURE 2A

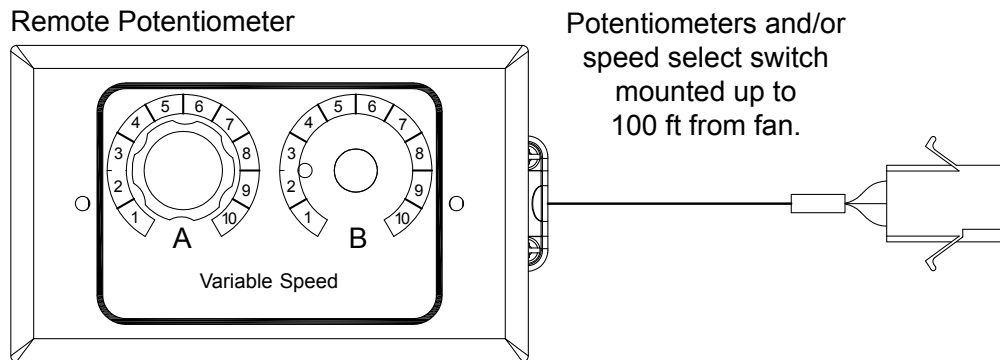

FIGURE 2B

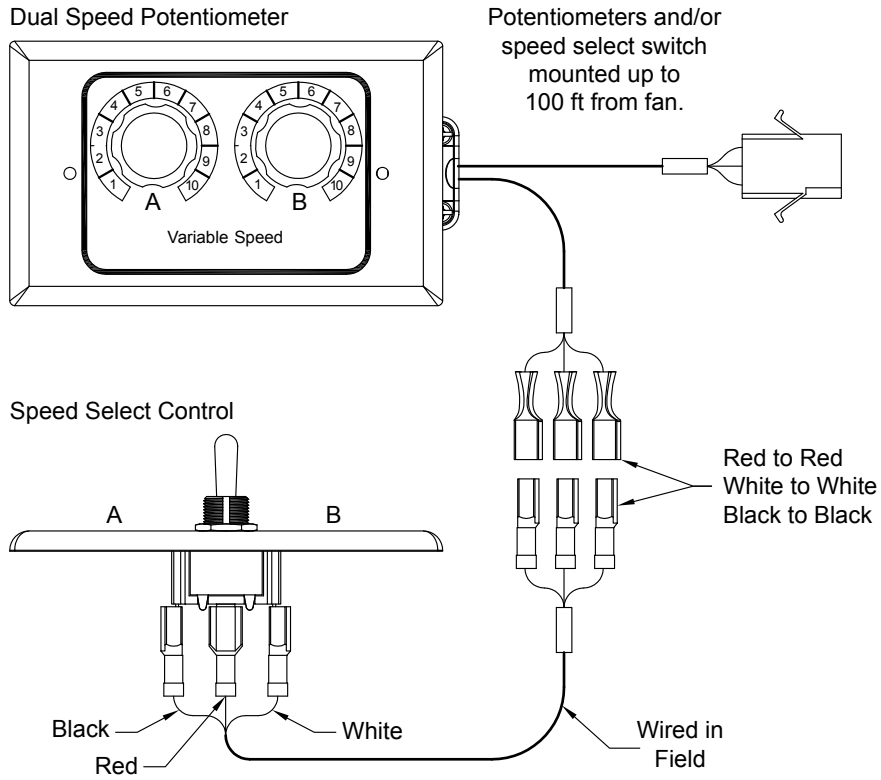
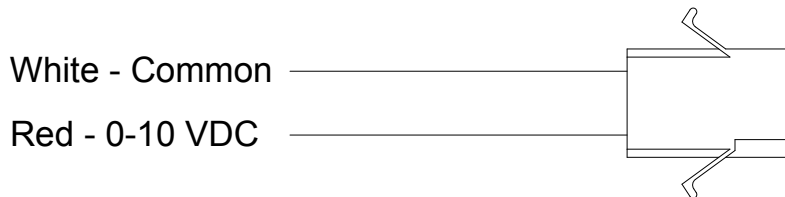

FIGURE 2C

Building Supplied Controller Harness



PerfectSpeed® Motor and User Interface Troubleshooting

Motor Is Not Running

If the PerfectSpeed® motor with User Interface isn't running, perform the following checks:

1. Ensure that both the PerfectSpeed® motor and User Interface have proper line voltage for intended application.
2. Turn the User Interface on-board potentiometer fully clockwise (100% demand) and check to see if the motor runs.
3. If 0-10 VDC input is in use, disconnect the external input from the User Interface and perform Check 2.
4. Check the digital read-out of User Interface for an error code:

Error Code	Reason	Action
E1	No Communication	Remove power from both the PerfectSpeed® motor and User Interface for four (4) minutes, then reconnect power and test again. Check the communication cable connection between the PerfectSpeed® motor and User Interface. Check the continuity of communication cable (pin 1-1, pin 2-2 pin 3-4, and pin 4-3).
E2	Low Voltage	This is a reading from the PerfectSpeed® motor itself. Ensure that there is at least 71 VAC (for 115 VAC applications) or 142 VAC (for 230 VAC applications).
E3	Not a NMC Motor	Connect to a NMC motor.

Check 2: Electrical Troubleshooting

1. Disconnect or remove power to the equipment being serviced and allow four (4) minutes for the capacitors to discharge any residual voltage.
2. Check the rotation and speed of the motor. Determine if the motor can spin freely by hand without effort or assisted means. If any binding occurs, replace the motor and control unit.
3. Determine whether the system is wired for 120 VAC power or 240 VAC power.
4. Disconnect the power cord from the connector on the control unit. Inspect the power cord for bent, damaged, or recessed wires and terminals.
5. Disconnect or remove AC power to the equipment serviced and allow four (4) minutes for the capacitors to discharge any residual voltage.
6. Proceed to Check 3.

Check 3: Motor Verification

1. Disconnect or remove AC power to the equipment serviced and allow four (4) minutes for the capacitors to discharge any residual voltage.
2. Make sure that the motor shaft spins freely by hand without effort in both directions.
3. DC motors can have a jump filling when rotating this is perfectly normal, if motor does not rotate at all motor needs to be replaced.

Final Checks of the Motor

1. Check the mounting and fastening of the motor and control unit. Make sure the motor and the control unit are securely attached together and mounted tightly in the system.
2. Check the control unit connectors. Inspect for shorts, detached wiring, or loose connections.
3. Check the motor and verify the rotation of the driven load. Make sure it spins freely by hand in both directions without effort or assisted means.
4. Check all circuit breakers.

MAINTENANCE

1. Under normal usage, no spare parts are expected to be required for one year of operation. Recommended spare parts are shown on pages 4 and 5.
2. **CAUTION:** Before proceeding, make sure electrical service to fan is locked in "OFF" position.

WINDMILLING: Even when the power supply is locked out, fans may cause injury or damage if the impeller is subject to "windmilling" which is the turning of the impeller and drive components due to a draft in the system. To guard against this hazard, the impeller should be secured to physically restrict rotational movement.

3. Motor bearings are prelubricated. Consult information printed on motor for lubrication instructions.
4. **REGULAR MAINTENANCE:** Determined by the condition of the air passing through the fan, regularly scheduled inspection of all fan parts establishes a good maintenance routine. When the air is clean, maintenance can be as infrequent as once a year. When air is contaminated with grease vapors from cooking operations, maintenance may be required as often as once a week. Regular maintenance should include inspection and cleaning of all fan parts to remove all grease and other foreign particles from the entire wheel surface including blades and front and back plates.

WARNING! Care must be taken when cleaning the wheel to remove grease and other foreign particles. Damage to the wheel can occur if it is hit or if pressure is applied causing the wheel to be distorted. Either case can cause serious vibration and damage to the fan.

SET SCREW TIGHTENING SCHEDULE

1. Before initial operation of the fan, tighten set screws according to the procedure outlined below.
2. After 500 operating hours or three months, whichever comes first, tighten set screws to the full recommended torque.
3. At least once a year, tighten set screws to the full recommended torque.

PROCEDURE FOR TIGHTENING SET SCREWS IN BEARINGS AND HUBS

One Set Screw Application

Using a torque wrench, tighten the set screw to the torque recommended in Table 1.

Two Set Screw Application

1. Using a torque wrench, tighten one set screw to half of the torque recommended in Table 1.
2. Tighten the second set screw to the full recommended torque.
3. Tighten the first set screw to the full recommended torque.

Table 1. Recommended Tightening Torque for Set Screws

Set Screw Diameter	Torque (in-lbs)
#10	35
1/4	80
5/16	126
3/8	240
7/16	384
1/2	744
9/16	1080
5/8	1500
3/4	2580
7/8	3600
1	5400

VARIABLE FREQUENCY DRIVES AND MOTORS

There are occasions when a Variable Frequency Drive (VFD) will cause poor motor performance and possible damage. To avoid these problems, the Company recommends the following:

1. Select compatible motor and VFD inverter; if possible, the motor and the inverter should be from the same manufacturer or at least the inverter selected should be recommended by the motor manufacturer.
2. A motor shaft grounding system should be used to prevent motor bearing damage from eddy currents.

NOTE: The Company will not honor motor warranty claims if the customer fails to follow these recommendations.

Sizes 10-36

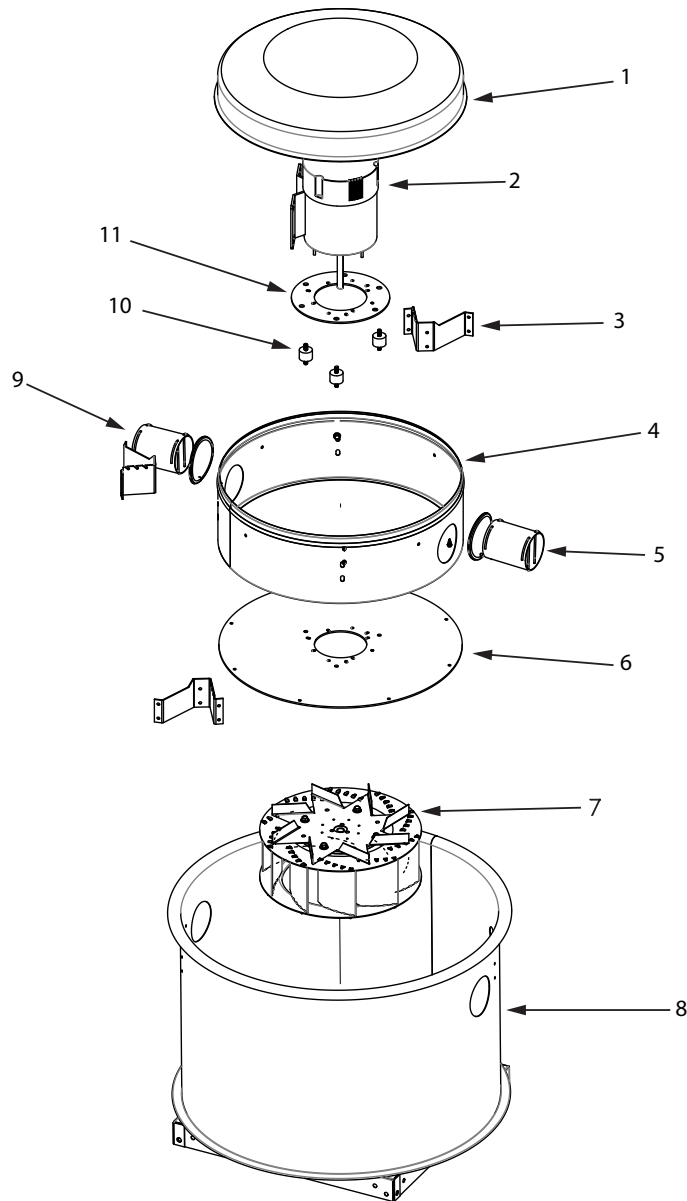

NOTES

1. Fan shown is standard unit. Units built for restaurant service do not have internal wiring post (No. 7) or birdscreen (No. 2). Unit shown is model with UL762 and externally mounted disconnect switch.
2. Fan shown is roof fan. Wall fan applications require wall bracket accessory not shown.

1PARTS LIST LEGEND

No.	Description	Qty.	No.	Description	Qty.
1	Motor Enclosure	1	7	Wheel	1
2	ECM Motor*	1	8	Windband Assembly	1
3	V Bracket	4	9	Rub Channel	1
4	Motor Enclosure Band	1	10	Motor Mount Rubber	4
5	Breather Tube	2	11	EC Motor Base	1
6	Motor Base	1			

* Recommended spare parts
Ludwig Fasteners not shown

TERMS AND CONDITIONS OF SALE

THESE TERMS AND CONDITIONS OF SALE ("TERMS") CONTAIN VERY IMPORTANT INFORMATION REGARDING YOUR PURCHASE, AS WELL AS CONDITIONS, LIMITATIONS, AND EXCLUSIONS THAT APPLY TO YOU AND YOUR PURCHASE. PLEASE READ THEM CAREFULLY. YOUR PURCHASE IS EXPRESSLY LIMITED TO AND MADE CONDITIONAL UPON THE EXCLUSIVITY OF THESE TERMS. ANY PROPOSAL FOR DIFFERENT TERMS OR ANY ATTEMPT TO VARY, IN ANY DEGREE, ANY OF THESE TERMS IS EXPRESSLY REJECTED.

1. **Acceptance.** These Terms govern any purchase made from North American Kitchen Solutions Incorporated ("NAKS"). These Terms, the Manual in which they are contained, installation and maintenance instructions, the applicable invoice, and any documents incorporated or referred to herein or therein, including any future paper or electronic releases issued by NAKS, constitute the "Order." The Order is the entire contract between you, the buyer, and NAKS, the seller, for products purchased from NAKS. These Terms apply to the Order unless expressly modified or waived by an officer of NAKS. An Order may only be cancelled by you upon payment of reasonable cancellation charges for expenses incurred or commitments made by NAKS. Captions in these Terms are for convenience only.
2. **Pricing.** The price for NAKS' goods, material, equipment, or items ("Products") is complete, and no deductions, credits, or offsets may be made without NAKS' express written consent. Prices are subject to change and surcharges in the event of cost increases in materials and transportation. All complete component accessory material manufactured by others and furnished with Products such as motors, drives, vibration equipment, controls, or other completely assembled component structures, are subject to adjustment to the price at time of shipment regardless of the date of original order entry.
3. **Sales and Similar Taxes.** NAKS' prices do not include sales, use, excise, or similar taxes. Present or future sales, use, excise, or other similar tax applicable to the sale of Products shall be paid you, unless an acceptable tax exemption certificate is provided to NAKS.
4. **Payment.** NAKS reserves the right to require full or partial payment in advance of any order. Pro-rata payments are due as shipments are made. Each shipment or delivery shall constitute a separate sale, and the default of any shipment or delivery shall constitute a separate sale, and the default of any shipment or delivery shall not vitiate the contract as to other shipments or deliveries.
5. **Delivery.** Shipping and delivery dates are estimates only. No delay in delivery will subject NAKS to any costs, damages or fees for late delivery. Delivery of Products is made F.O.B. point of shipment, unless otherwise stated. NAKS shall not be liable for delay due to causes beyond its reasonable control (i.e., force majeure events). In the event of such a delay, the date of delivery shall be extended for a period equal to the time lost by reason of the delay.
6. **Changes.** NAKS may make changes, including improvements and additions, in the technical requirements, specifications, designs, materials, packaging, and place of delivery, method of transportation, quantities, or delivery schedules of the Products by notifying you.
7. **Safety.** The Products may be designed to serve multiple applications. NAKS offers a range of safety equipment, including guards and other devices, as may be required to meet customer specifications. Without exception, NAKS recommends that all orders include applicable safety devices. Use of Products ordered without applicable safety devices are your sole responsibility. You warrant that you have determined and acquired any and all safety devices required for the Products. Weather covers and guards for motor and V-belt drives, couplings, shafts and bearings, along with inlet and outlet screens, are optional accessories noted in the price list.
8. **Title.** Title and right of possession of Products remains with NAKS until all payments (including deferred payments whether evidenced by notes or otherwise) shall have been received to the satisfaction of NAKS and you agree to do all acts necessary to perfect and maintain such title and right in NAKS and not to subject any Products to any liens or encumbrances until such payment is made in full.
9. **Governing Law.** This Order shall be governed by and construed according to the laws of the State of Ohio (excluding the conflict of law provisions thereof). At NAKS' discretion, any action relating directly or indirectly to the Order shall be brought exclusively in the Common Pleas Court of Cuyahoga County, Ohio or the United States District Court for the Northern District of Ohio, Eastern Division, and you irrevocably waive any objection to the jurisdiction of, or venue in, either of these courts and agree that the acceptance of the Order constitutes doing business in the State of Ohio.
10. **Arbitration.** At NAKS' discretion, any dispute arising under or in connection with any Order may be submitted to binding arbitration administered by the American Arbitration Association under its Commercial Arbitration Rules, and judgment on the award rendered by the arbitrator may be entered in any court having jurisdiction thereof. The dispute shall be resolved by one neutral arbitrator who shall have no affiliation with either you as the buyer or with NAKS and shall be selected by the American Arbitration Association office, and held in, Cleveland, Ohio.

WARNING. NAKS' Products are designed and manufactured to provide reliable performance but they are not guaranteed to be 100% free of defects. Even reliable products will experience occasional failures and this possibility should be recognized by the buyer and all end users. If Products are used in life support ventilation systems where failure could result in loss or injury, the buyer and all end users should provide adequate back-up ventilation, supplementary natural ventilation or failure alarm system, or acknowledge willingness to accept the risk of such loss or injury. **DO NOT USE IN HAZARDOUS ENVIRONMENTS** where a fan's electrical system could provide ignition to combustible or flammable materials unless unit is specifically built for hazardous environments. Comply with all local and national safety codes including the National Electrical Code (NEC) and National Fire Protection Act (NFPA).

CAUTION. Guards must be installed when fan is within reach of personnel or within eight (8) feet (2.5 m) of working level or when deemed advisable for safety.

DISCLAIMER. NAKS has made a diligent effort to illustrate and describe the Products accurately in all materials; however, such illustrations and descriptions are for the sole purpose of identification and do not express or imply any warranty.

LIMITED WARRANTY

WARRANTY AND DISCLAIMER. This limited warranty extends to you the original purchaser only with proof of purchase. NAKS warrants that Products shall be free from original defects in workmanship and materials for one year from date of shipment (except for the warranty periods noted for products listed below), provided the Products have been properly handled, stored, installed, serviced, maintained and operated. This warranty shall not apply to Products which have been altered or repaired without NAKS' express authorization, or altered or repaired in any way so as, in NAKS' judgment, to affect performance or reliability, nor which have been improperly installed or subjected to misuse, negligence, or accident, or incorrectly used in combination with other substances. You assume all risks and liability for results of use of all Products.

Evaporative cooling pads are warranted to be free of defects in materials and workmanship for a period of one year from date of shipment provided same have been properly handled, stored, installed, serviced, maintained and operated; and further, not subjected to excessive heat, corrosive agents or chemicals, or mechanical abuse that may cause tearing, crushing or undue deterioration, nor used on a system or in a manner other than that for which it was designed as explained in the Order.

LIMITATION OF REMEDY AND DAMAGES. All claims under this warranty must be made in writing and delivered by U.S. Mail to:

North American Kitchen Solutions
172 Reaser Court
Elyria, OH 44035
Attn: WARRANTY CLAIMS DEPARTMENT

All Product claims must be made within 15 days after discovery of the defect and prior to the expiration of one year from the date of shipment. Claims made beyond that period are barred. Within 30 days after receipt of a timely claim, NAKS shall have the option either to inspect the Product at its location or request its return to NAKS at your expense. NAKS shall replace, or at its option repair, free of charge, any Product it determines to be defective, and it shall ship the repaired or replacement product to you F.O.B. point of shipment; provided, however, if in NAKS' judgment circumstances are such to prohibit repair or replacement to remedy the warranted defects, your sole and exclusive remedy shall be a refund of any part of the invoice price, paid to NAKS, for the defective Product or part.

NAKS is not responsible for the cost of removal of the defective Product or part, damages due to removal, or any expenses incurred in shipping the Product, or the installation of the repaired or replaced Product or part.

The warranties set forth above do not apply to any components, accessories, parts or attachments manufactured by other manufacturers; such being subject to the manufacturer's warranty, if any. To the extent not prohibited by the manufacturer's warranty, NAKS shall pass to you such manufacturer's warranty.

THIS WARRANTY IS IN LIEU OF ALL OTHER WARRANTIES, EXPRESS OR IMPLIED, ARISING BY LAW OR OTHERWISE, INCLUDING WITHOUT LIMITATION THE IMPLIED WARRANTIES OF MERCHANTABILITY AND FITNESS FOR A PARTICULAR PURPOSE, WHICH ARE HEREBY EXPRESSLY DISCLAIMED AND WAIVED. THIS WARRANTY CONSTITUTES NAKS SOLE AND EXCLUSIVE WARRANTY FOR DEFECTIVE GOODS AND PURCHASER'S SOLE AND EXCLUSIVE REMEDY FOR DEFECTIVE PRODUCTS.

No employee, agent, dealer, or other person is authorized to give any warranties on behalf of NAKS or to assume for it any other liability in connection with any of its products except in writing and signed by an officer of NAKS.

LIMITATION OF LIABILITY. NAKS' cumulative liability to you and any other persons for all claims in any way relating to or arising out of the Products, including, but not limited to, any cause of action sounding in contract, tort, or strict liability, shall not exceed the total amount of the purchase price paid for those Products which are the subject of any such claim. This limitation of liability is intended to apply without regard to whether other provisions of this agreement have been breached or have proven ineffective even if NAKS has been advised of the possibility of such claims or demands. In no event shall NAKS be liable to you or any other person for any loss of profits or any incidental, special, exemplary, or consequential damages for any claims or demands brought by you or such other persons. BECAUSE SOME JURISDICTIONS DO NOT ALLOW THE EXCLUSION OR LIMITATION OF LIABILITY FOR CONSEQUENTIAL OR INCIDENTAL DAMAGES, THIS LIMITATION MAY NOT APPLY TO YOU.

NAKS' maximum liability to you and to any end user is as set forth above. NAKS makes no warranty to anyone for any products not manufactured by it and shall have no liability for any use or installation of any products (whether manufactured by NAKS or other manufacturers) not specifically authorized by this sale. You acknowledge various warnings by NAKS regarding the Products and its installation and use. If NAKS incurs any claims, lawsuits, settlements, or expenses (including attorney fees) for any loss, injury, death or property damage including, but not limited to, claims arising out of your or any end user's installation or use of the Products, you agree to indemnify and hold NAKS harmless.

REPLACEMENT PARTS. If replacement parts are ordered, purchaser warrants that the original components in which these replacement parts will be placed are in satisfactory working condition, and when said replacement parts are installed, the resultant installation will operate in a safe manner, at speeds and temperatures for which the original product was purchased.

TECHNICAL ADVICE AND RECOMMENDATIONS, DISCLAIMER. Notwithstanding any past practice or dealings or any custom of the trade, sales shall not include the furnishing of technical advice or assistance or system design. Any such assistance shall be at NAKS' sole option and may be subject to additional charge(s).

NAKS assumes no obligation or liability on account of any recommendations, opinions or advice as to the choice, installation or use of Products. Any such recommendations, opinions or advice are given and shall be accepted at your and the end-user's risk and shall not constitute any warranty or guarantee of such Products or their performance.