



VENTLESS EXHAUST HOOD

OPERATORS MANUAL AND PARTS LIST

REV. JUNE 2020



NORTH AMERICAN KITCHEN SOLUTIONS, INC.
172 REASER COURT
ELYRIA, OH 44035
PHONE: (800) 854-3267
FAX: (800) 365-2100

SPECIFIC SAFETY PRECAUTIONS

For your safety, please observe the following precautions when operating or servicing your ventless exhaust hood. Read the following important safety information carefully to avoid personal injury and/or damage to the equipment.

CAUTION/WARNING!

- Consult a qualified electrician to ensure all of the following guidelines are met:
 - All electrical specifications and codes are followed.
 - Circuit breakers and wiring are of sufficient rating and gauge.
 - The unit is properly grounded and all electrical specifications were followed during installation.
- Improper installation, adjustment, alteration, service or maintenance could result in death or serious injury and/or equipment/property damage, and will void the warranty.
- **DO NOT** use or store gasoline, other flammable liquids or vapors in the vicinity of this or any other appliance.
- Failure to comply with **DANGER** notices may result in death or serious injury and/or equipment/property damage, and will void the warranty.

WARNING

- **DO NOT** operate the unit unless you understand the components and the intended use.
- The unit must remain in the upright position.
- Exercise care when removing the wooden crate from around the unit.
- Failure to comply with WARNING notices could result in death or serious injury and/or equipment/property damage and will void the warranty.

CAUTION

- Ensure the unit is positioned to maintain **18" of clearance above the hood body** (excluding dampers), and **30" clear to the left** (side with the pull station when equipped with Fire System), 0" to the rear, and 0" to the right. If the pull station is on the right per special request, maintain 30" clearance on the right side and 0" on the left. Failure to maintain safe distances may result in fire.
- The unit must be adequately and properly grounded. Improper grounding may result in electrical shock.
- Consult an electrician to ensure all electrical specifications have been met and the unit is properly grounded.
- The wiring diagrams contained in this manual should aid your electrician in the installation of your unit.
- Exercise care around the Control Panel to maintain proper operation. The electronic components of the Control Panel are impact-sensitive.
- Turn off the unit and unplug the power cord before cleaning or performing maintenance.

DO NOT hose down the unit's interior or exterior with water.

During cleaning of the unit:

- **DO NOT** steam clean.
- **DO NOT** use products containing chlorine.
- **DO NOT** use abrasive products, steel wool or scouring pads.
- **DO NOT** modify, alter or add attachments to this equipment!
- Failure to comply with these **CAUTION** notices may result in equipment/property damage and will void the warranty.

NOTE:

- If the crate is damaged upon receipt, **immediately** inspect the unit and notify the carrier of any damage to the unit.
- To aid the electrician, an electrical wiring diagram is contained in this manual. Refer to the wiring diagram during installation or servicing.
- Comply with all appropriate state and/or local health regulations regarding the cleaning and sanitation of this equipment.

DIMENSIONS

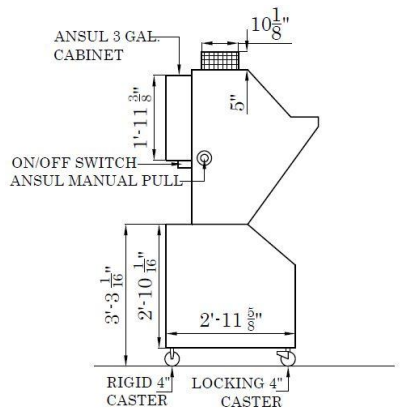

LEFT SIDE ELEVATION VIEW

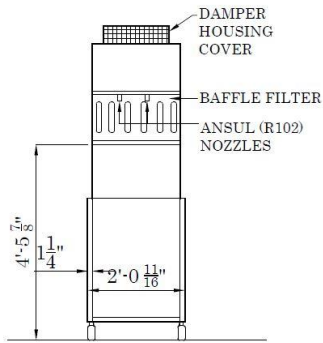

FRONT ELEVATION VIEW

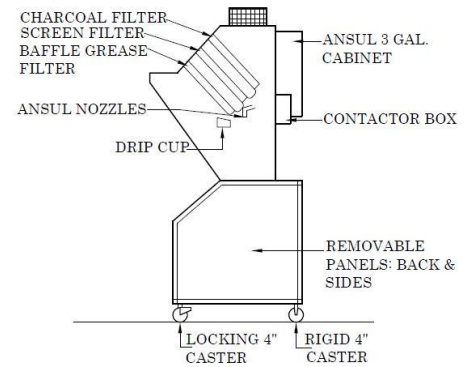

RIGHT SIDE ELEVATION VIEW

MODEL VH-24

REGULATORY LISTINGS (CERTIFICATIONS):

The Ventless System shall be built in accordance to NFPA96, be UL listed, and comply with UL710B Standards. Hoods shall be tested to comply with NSF Sanitation Mark.

Unit Weight: 565 lbs.

UNPACKING:

Your unit may arrive enclosed in a wooden crate. The Hood is secured to a wooden platform by means of high-tensile strength strapping.

NOTE:

- If the crate is damaged, immediately inspect the unit and notify the carrier of any damage to the unit.
- Exercise care when lifting or moving the unit.
- Exercise care when removing the wooden crate from around the unit.

LOCATE AND IDENTIFY THE FOLLOWING COMPONENTS AFTER UNPACKING:

- Hood and Fire Suppression System
- Floor Stand and Contactor Box
- ANSULEX ® Fire Suppressant, 3.0 Gallon
- Drip Cup
- Grease (baffle) Filter, Air (Mesh) Filter, Charcoal Filter

DIMENSIONS

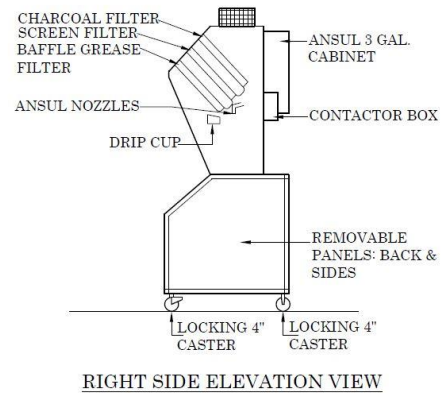
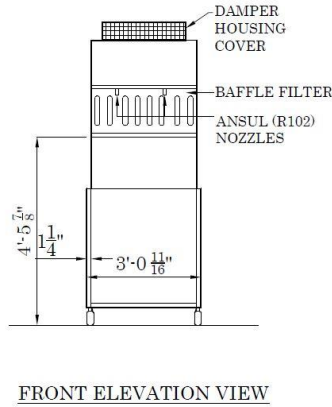
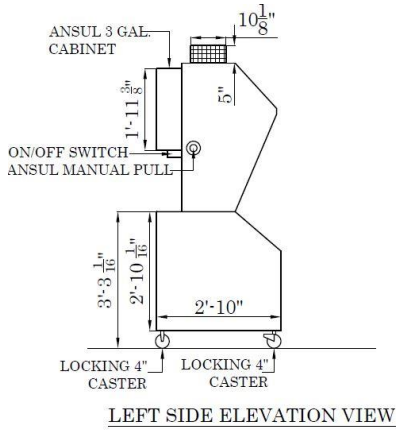

MODEL VH-36

REGULATORY LISTINGS (CERTIFICATIONS):

The Ventless System shall be built in accordance to NFPA96, be UL listed, and comply with UL710B Standards. Hoods shall be tested to comply with NSF Sanitation Mark.

Unit Weight: 735 lbs.

UNPACKING:

Your unit may arrive enclosed by a wooden crate. The Hood is secured to a wooden platform by means of high-tensile strength strapping.

NOTE:

- If the crate is damaged, immediately inspect the unit and notify the carrier of any damage to the unit.
- Exercise care when lifting or moving the unit.
- Exercise care when removing the wooden crate from around the unit.

LOCATE AND IDENTIFY THE FOLLOWING COMPONENTS AFTER UNPACKING:

- Hood and Fire Suppression System
- Floor Stand and Contactor Box
- ANSULEX ® Fire Suppressant, 3.0 Gallon
- Drip Cup
- Grease (baffle) Filter, Air (Mesh) Filter, Charcoal Filter

DIMENSIONS

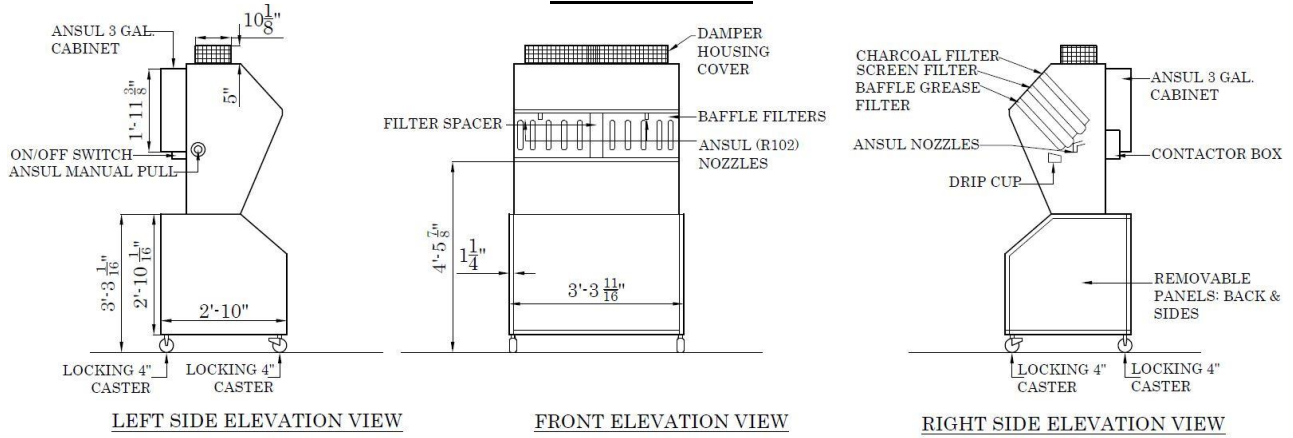

MODEL VH-42

REGULATORY LISTINGS (CERTIFICATIONS):

The Ventless System shall be built in accordance to NFPA96, be UL listed, and comply with UL710B Standards. Hoods shall be tested to comply with NSF Sanitation Mark.

Unit Weight: 845 lbs.

UNPACKING:

Your unit may arrive enclosed by a wooden crate. The Hood is secured to a wooden platform by means of high-tensile strength strapping.

NOTE:

- If the crate is damaged, immediately inspect the unit and notify the carrier of any damage to the unit.
- Exercise care when lifting or moving the unit.
- Exercise care when removing the wooden crate from around the unit.

LOCATE AND IDENTIFY THE FOLLOWING COMPONENTS AFTER UNPACKING:

- Hood and Fire Suppression System
- Floor Stand and Contactor Box
- ANSULEX ® Fire Suppressant, 3.0 Gallon
- Drip Cup
- Grease (baffle) Filter, Air (Mesh) Filter, Charcoal Filter

DIMENSIONS

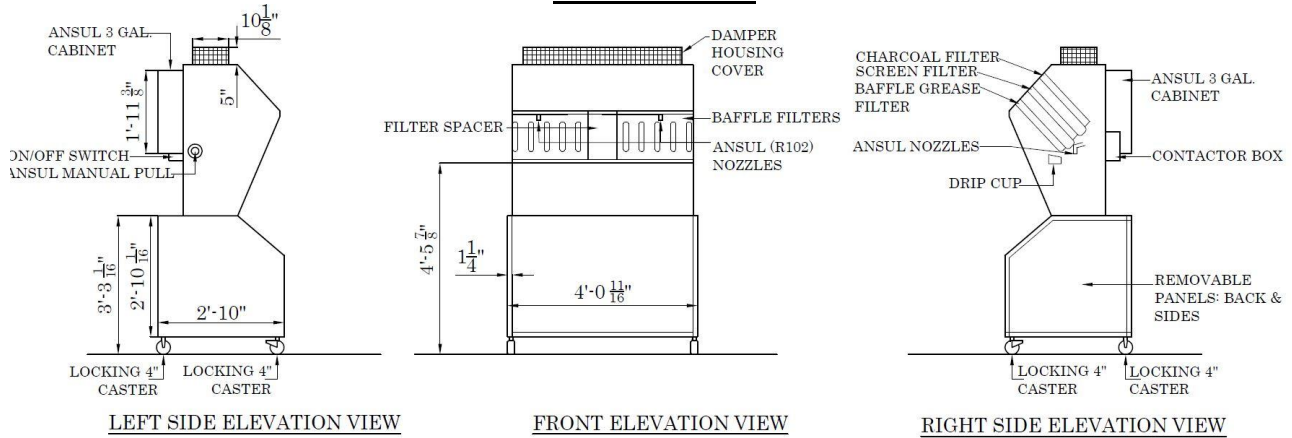

MODEL VH-48

REGULATORY LISTINGS (CERTIFICATIONS):

The Ventless System shall be built in accordance to NFPA96, be UL listed, and comply with UL710B Standards. Hoods shall be tested to comply with NSF Sanitation Mark.

Unit Weight: 985 lbs.

UNPACKING:

Your unit may arrive enclosed by a wooden crate. The Hood is secured to a wooden platform by means of high-tensile strength strapping.

NOTE:

- If the crate is damaged, immediately inspect the unit and notify the carrier of any damage to the unit.
- Exercise care when lifting or moving the unit.
- Exercise care when removing the wooden crate from around the unit.

LOCATE AND IDENTIFY THE FOLLOWING COMPONENTS AFTER UNPACKING:

- Hood and Fire Suppression System
- Floor Stand and Contactor Box
- ANSULEX ® Fire Suppressant, 3.0 Gallon
- Drip Cup
- Grease (baffle) Filter, Air (Mesh) Filter, Charcoal Filter

ELECTRICAL REQUIREMENTS

- Consult a qualified electrician to ensure all electrical specifications have been met.
- The unit must be adequately and properly grounded. Improper grounding may result in electrical shock. Always refer to your local electrical code to ensure proper grounding of this and any other electrical equipment. Always consult with an electrician or other qualified service person to ensure breakers and wiring are of sufficient rating and gauge for the equipment being operated.
- Improper installation, adjustment, alteration, service or maintenance could result in death or serious injury and/or equipment/property damage, and void the warranty.

Model #	Voltage	Hz	Phase	Amps
VH-24	208-240	60	1-3	75

NOTE: 3 AMPS FOR HOOD

Model #	Voltage	Hz	Phase	Amps
VH-36	208-240	60	1-3	75

NOTE: 4.5 AMPS FOR HOOD

Model #	Voltage	Hz	Phase	Amps
VH-42	208-240	60	1-3	75

NOTE: 4.5 AMPS FOR HOOD

Model #	Voltage	Hz	Phase	Amps
VH-48	208-240	60	1-3	75

NOTE: 6 AMPS FOR HOOD

CONNECT HOOD POWER:

- Apply AC power to the Contactor box.
- The power requirement of the fryer will determine the input.
- Remove plug (if present) from the AC power cord of the fryer; connect the fryer power cord to the contactor output
- All connections should be made by a qualified electrician to ensure all electrical specifications have been met and comply with all local codes.

HOOD AND APPLIANCE INTERLOCK CONNECTION

This connection will cause the appliance below the hood to shut down if any of the following occurs:

- Any filter becomes excessively dirty and does not allow proper airflow through the hood.
- Any filter is missing or not installed properly.
- Fire Extinguisher System is activated.

NOTE: IF FIRE SYSTEM IS FIELD INSTALLED, WIRING MUST BE VERIFIED BY LICENSED ANSUL SYSTEM INSTALLER AND PERFORMED TO MEET ALL STATE AND LOCAL CODES.

WIRING DIAGRAM

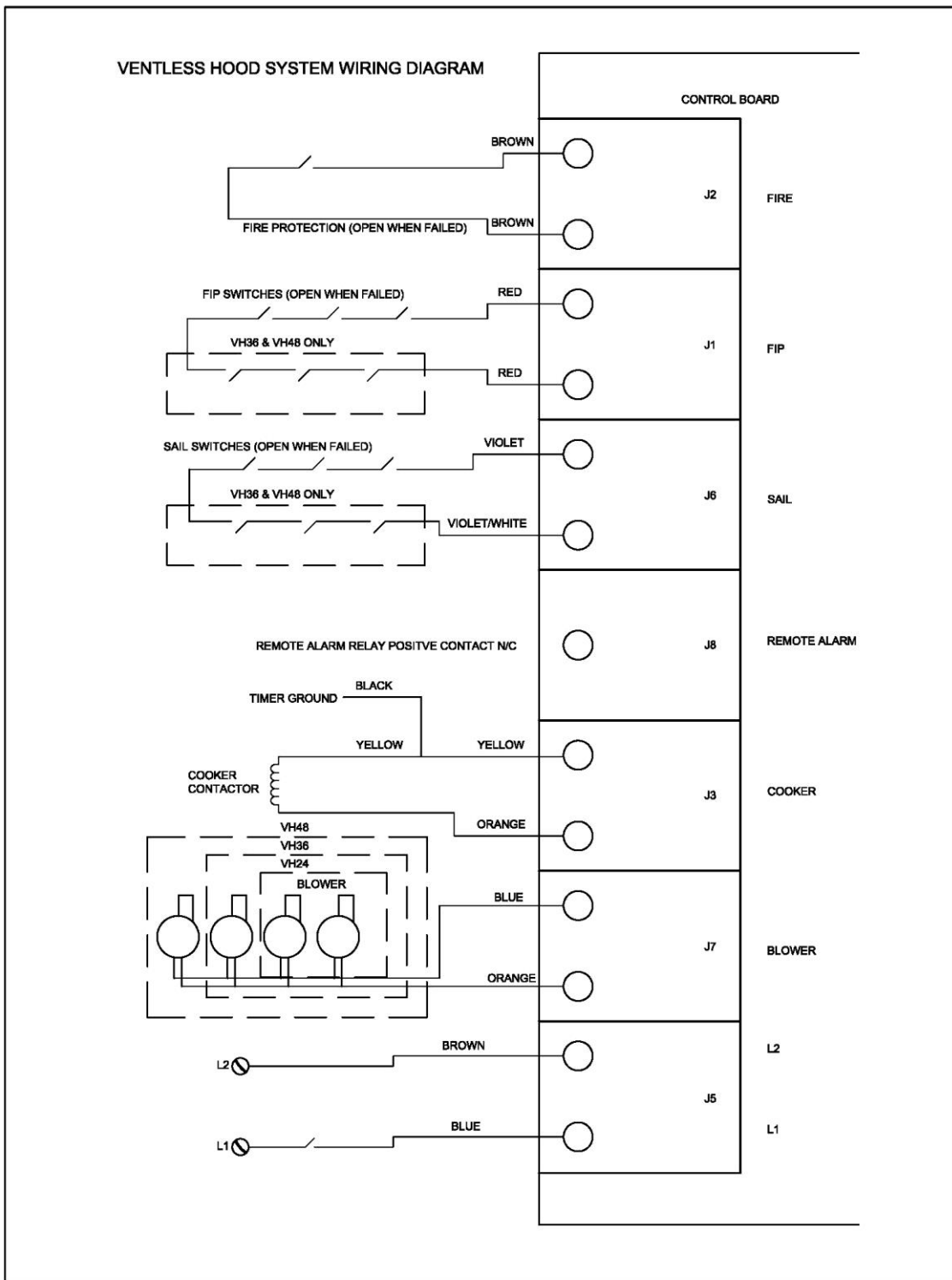

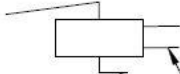
Ansul 
 Microswitch Wires

**NOTE: PRIOR TO INSTALLATION, POWER MUST BE DISCONNECTED.
 WIRING DIAGRAM TO BE FOLLOWED IN ORDER TO INTEGRATE INTO FIRE SYSTEM.
 INSTALLATION SHALL BE PERFORMED TO MEET ALL STATE AND LOCAL CODES.
 ALL WIRING TO BE PER PAGES 9 & 10 OF THE INSTALLATION MANUAL.**

WIRING DIAGRAM CONT.

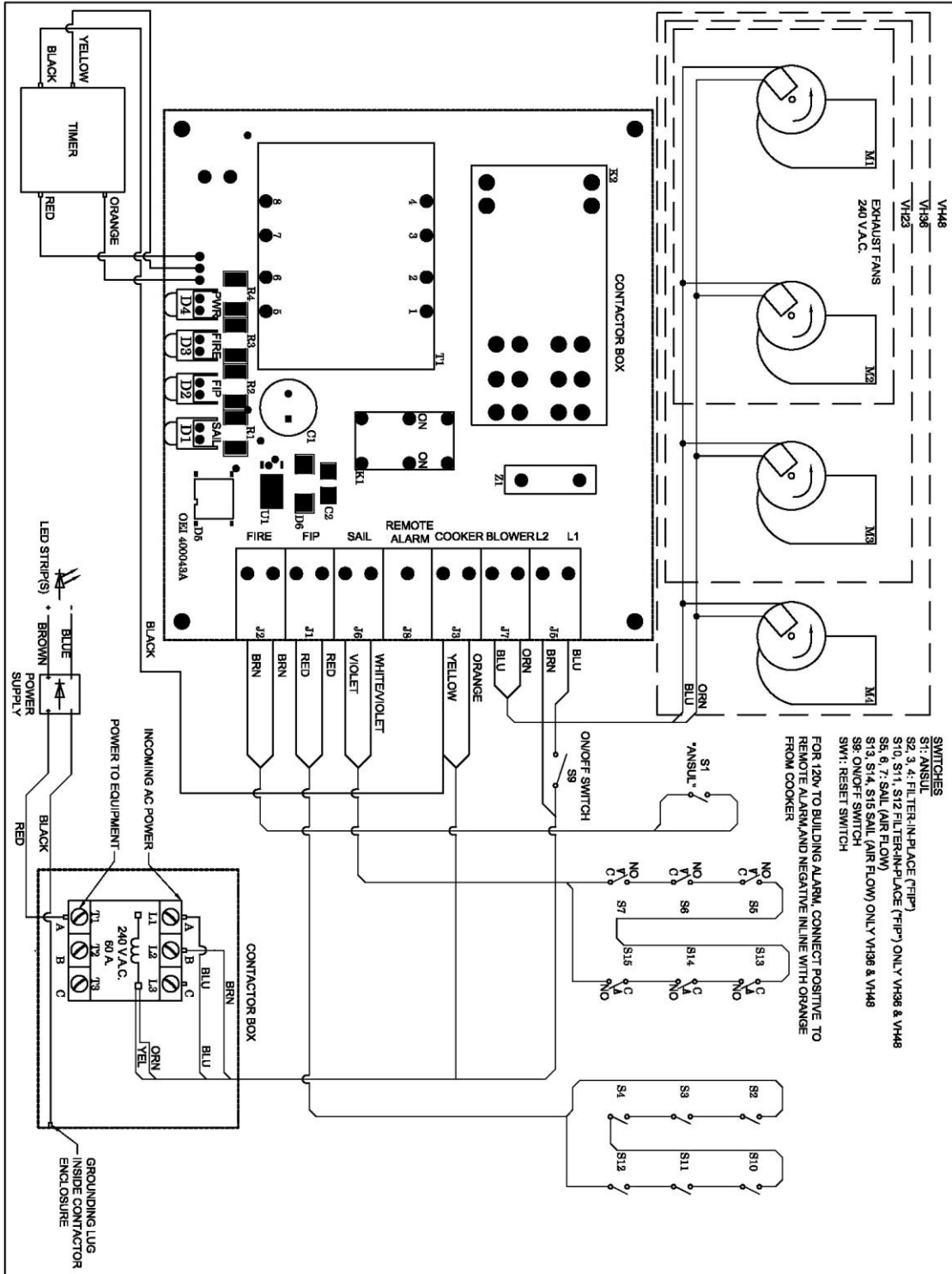

Clearances and Coverage:

- Ceiling 18” and Pull Station side 30”

Model	Surface Nozzles	Tank Size
VH-24	1N	3.0
VH-36	290	3.0
VH-42	290	3.0
VH-48	290	3.0

Note: Coverage for Fryers, Griddles, & Ranges - Cooking surface of each appliance cannot exceed 480 square inches.

FIRE SUPPRESSION SYSTEM

The fire suppression system used in your Ventless Hood System is an Ansul R-102 Restaurant Fire Suppression System (Standard UL 300 Listed).

- In accordance with the system’s listing, an authorized Ansul distributor must perform final installation, charging and testing of the system.
- The fire suppression system is designed and UL-listed to provide fire protection for cooking appliances such as fryers. It automatically protects your unit 24 hours per day.
- The integrated ANSUL system contains piping and nozzles.
- All nozzles have been factory installed in the proper operating position. **DO NOT MOVE OR ADJUST.**

This Hood also requires use of a Manual Pull System. The Manual Pull System is already integrated into your system if fire suppression system is factory installed.

NOTE: If Field installed, fire suppression system to be installed per the Field Installation Diagram for Conduit/Piping supplement attached to this manual

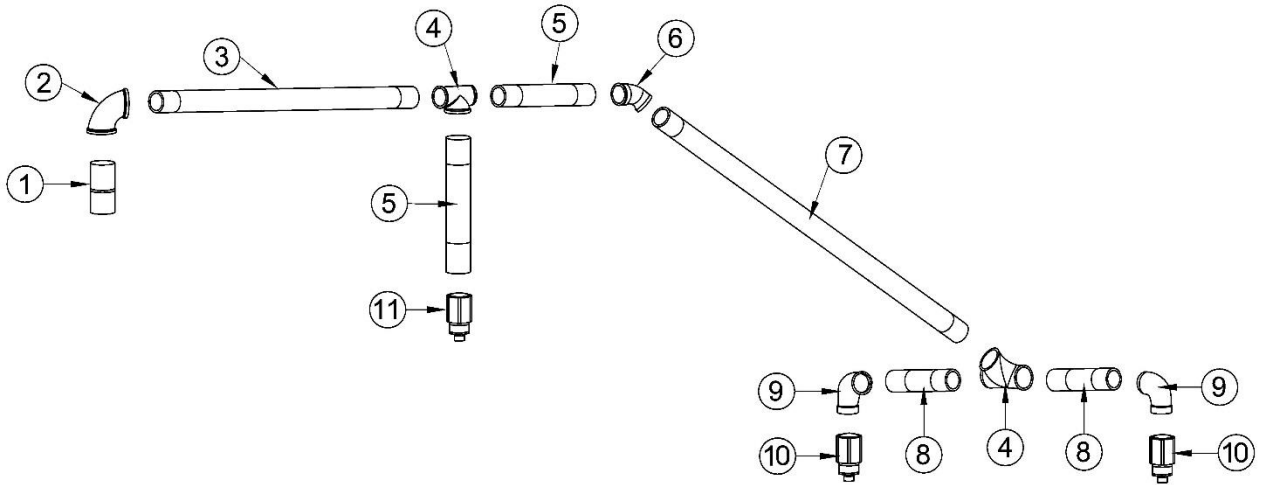

Item	Part No.		Black	Pipe
1	11-20018	10 5/8", 3/8" Black Pipe		
2	11-20109	Elbow, 3/8" Black Pipe		
3	11-20111	Pipe, 3/8"x 8 5/8" Black Pipe		
4	11-20094	Tee, 3/8",	Black	Pipe
5	11-20110	Pipe, 3/8"x 6" Black Pipe		
6	11-20097	45 Elbow, 3/8" Black Pipe		
7	11-20112	Pipe, 3/8" x 16" Black Pipe		
8	11-20013	Nipple, 3/8" x 2" Black Pipe		
9	11-20096	Elbow, 3/8" Black Pipe		
10	11-20120	Nozzle, Chromed (Ansul)		
11	11-20121	Nozzle, Chromed (Ansul) (2 required for 3 & 4 Foot)		

FIELD INSTALL SUPPRESSION DIRECTIONS

All Fire System Components to be installed by an **AUTHORIZED ANSUL INSTALLER**

COMPONENTS FOR INSTALLATION MUST INCLUDE ANSUL PARTS AS FOLLOWS:

- SINGLE TANK NITROGEN CARTRIDGE 34 OZ OR LT-20-R
- TERMINAL DETECTOR P/N 6538
- PULL ELBOWS - 7 REQUIRED, P/N 7423250
- PULL STATION P/N 4835
- ELECTRIC SWITCH P/N 423878
- FUSIBLE LINK 439245
- ANSUL TANK - 3 GALLON
- FIRE SUPPRESSION SYSTEM ENCLOSURE:
 - STAINLESS STEEL, 0.026" IN. THICK MIN, 23-1/2" X 16-1/2" X 7-1/2"

PRIOR TO INSTALLATION, POWER MUST BE DISCONNECTED. WIRING DIAGRAM TO BE FOLLOWED IN ORDER TO INTEGRATE INTO FIRE SYSTEM. INSTALLATION SHALL BE PERFORMED TO MEET ALL LOCAL CODES.

ALL PIPING TO BE ROUTED AND INSTALLED PER THIS DIAGRAM AND PAGES 14 AND 15 OF THE INSTALLATION MANUAL.

FIRE SYSTEM ENCLOSURE TO BE INSTALLED ON THE REAR OF THE HOOD SYSTEM AS SHOWN ON THE DIAGRAMS.

FOR 3'-0" AND 4'-0" UNITS, FOLLOWING FIRE TEST, THERMAL LINK MUST BE REPLACED. REPLACEMENT LINK IS SHIPPED WITH INSTALL MANUAL.

VH-24 Ventless Diagram

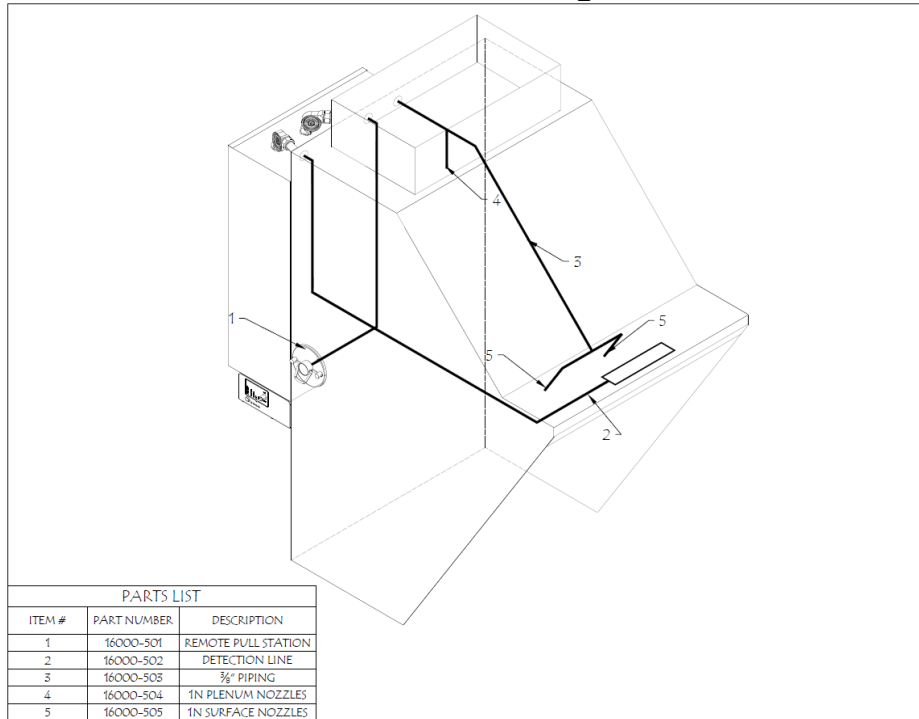

VH-36 Ventless Diagram

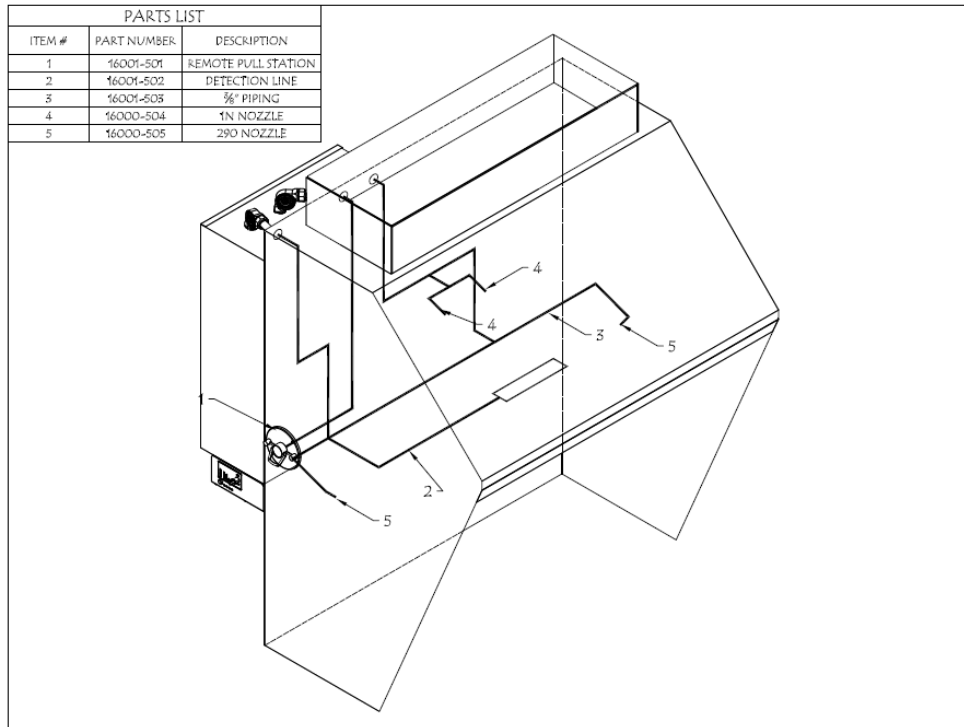

VH42 - Ventless Diagram

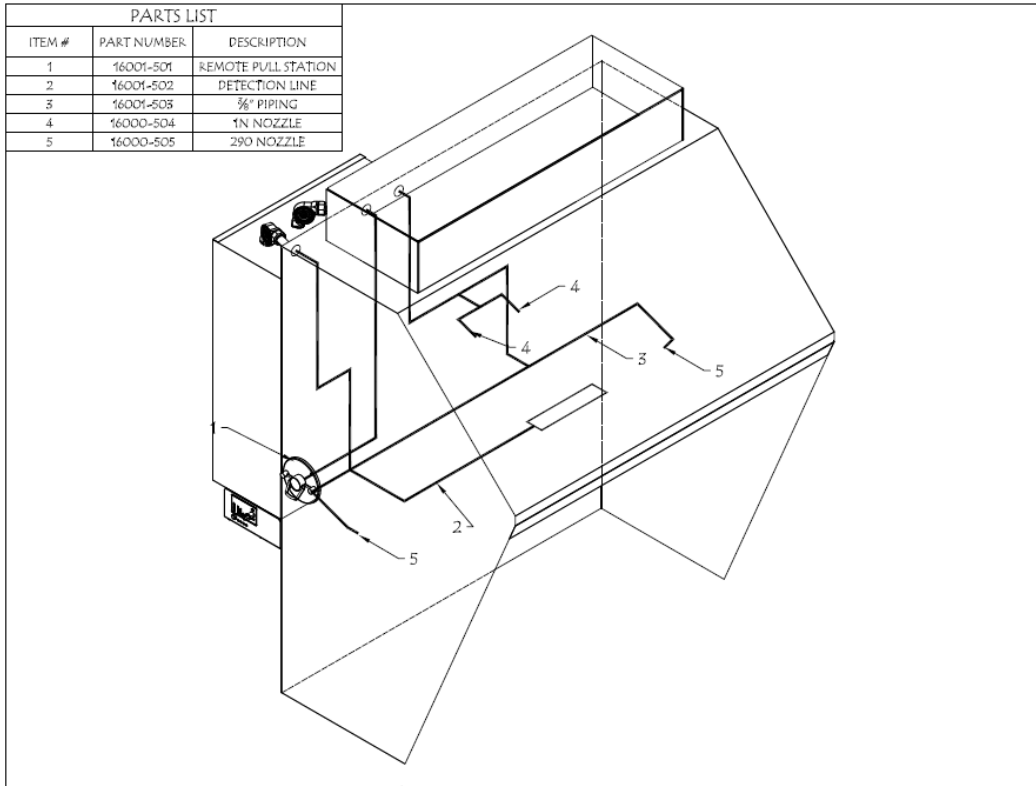

VH48 - Ventless Diagram

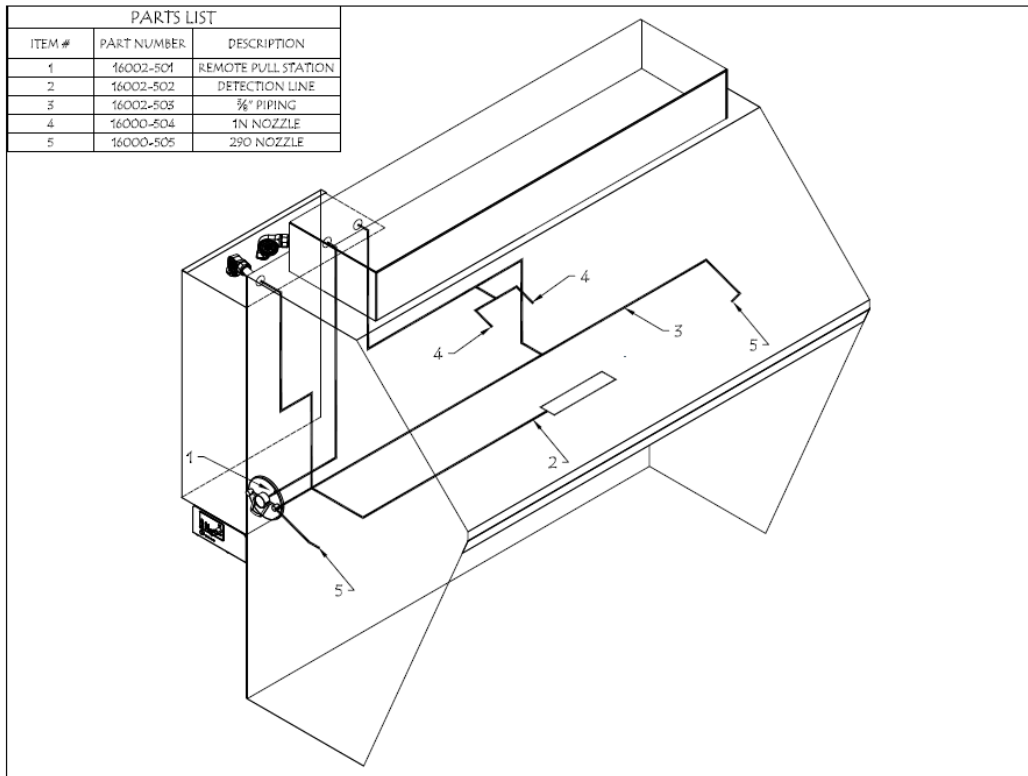

MAINTENANCE

Maintenance is necessary for your Ventless Hood System to maintain the unit's efficiency over time.

QUARTERLY HOOD CLEANING:

During cleaning of the unit:

DO NOT steam clean.

DO NOT use products containing chlorine.

DO NOT use abrasive products, steel wool or scouring pads.

Interior:

Disconnect power from the unit! Remove all filters from the hood. Using a mild degreaser with a soft towel or sponge, clean the entire Hood Plenum and Blower Sections. The hood must be cleaned every 3 months.

Exterior:

Disconnect power from the unit. Clean all external stainless-steel parts using a stainless-steel cleaner.

Filters:

Baffle filter: The Baffle Filter should be cleaned daily. Place the Baffle Filter in a sink and clean with a mild degreaser. Dry thoroughly, then reinstall in the unit.

Mesh Filter: Should be cleaned daily. Place the filter in a sink and clean with a mild degreaser. Dry thoroughly, then reinstall in the unit.

Charcoal Filter: Never attempt to clean the Charcoal Filter. Replace every 90 days. The reuse of a Charcoal Filter can cause damage to the unit.

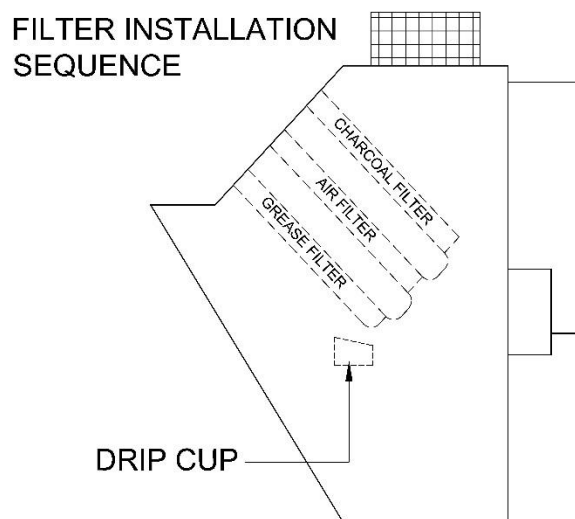

SEMI-ANNUAL FIRE SUPPRESSION SYSTEM SERVICING:

Service of the Fire Suppression System is to be conducted by qualified fire equipment personnel **ONLY!** Semi-annual (at minimum) servicing and inspections should be performed on the Fire Suppression System.

Such service shall consist of the following:

Place fire extinguishing system-locking bar on fire system when servicing hood.

1. Remove charging cartridge, inspect gasket for cuts and elasticity, coat gasket with extreme temperature grease and reinstall.
2. Remove tank, verify chemical is at proper level, clean and coat O-ring with extreme temperature grease and reinstall.
3. Check all nozzles to insure they are free of cooking grease buildup.
4. Test the remote manual pull station for activation and wear.
5. Install test link and cut to simulate automatic actuation.
6. Clean and inspect fusible links.
7. Inspect wire rope for wear at pulleys and detectors and replace if necessary.
8. Record maintenance date and maintain in a permanent file.

ANNUAL FIRE SUPPRESSION SYSTEM SERVICING:

Same as Semi-Annual but all fusible links must be replaced with new fusible links.

Maintenance Schedule

MAINTENANCE LOG				
Procedure:	Daily	Quarterly	Semi-Annually	Annually
Clean baffle filter	√			
Clean wire mesh Filter.	√			
Replace Charcoal filter.		√		
Interior hood cleaning.		√		
Exterior hood cleaning.		√		
Fire suppression system servicing.			√	√

TERMS AND CONDITIONS OF SALE

THESE TERMS AND CONDITIONS OF SALE (“TERMS”) CONTAIN VERY IMPORTANT INFORMATION REGARDING YOUR PURCHASE, AS WELL AS CONDITIONS, LIMITATIONS, AND EXCLUSIONS THAT APPLY TO YOU AND YOUR PURCHASE. PLEASE READ THEM CAREFULLY. YOUR PURCHASE IS EXPRESSLY LIMITED TO AND MADE CONDITIONAL UPON THE EXCLUSIVITY OF THESE TERMS. ANY PROPOSAL FOR DIFFERENT TERMS OR ANY ATTEMPT TO VARY, IN ANY DEGREE, ANY OF THESE TERMS IS EXPRESSLY REJECTED.

- 1. Acceptance.** These Terms govern any purchase made from North American Kitchen Solutions, Inc. (“NAKS”). These Terms, the Manual in which they are contained, installation and maintenance instructions, the applicable invoice, and any documents incorporated or referred to herein or therein, including any future paper or electronic releases issued by NAKS, constitute the “Order.” The Order is the entire contract between you, the buyer, and NAKS, the seller, for products purchased from NAKS. These Terms apply to the Order unless expressly modified or waived by an officer of NAKS. These Terms prevail over any of your general terms and conditions of purchase regardless whether or when you submitted the purchase order or such terms. Fulfillment of your order does not constitute acceptance of any of your terms and conditions and does not serve to modify or amend these Terms. An Order may only be cancelled by you upon payment of reasonable cancellation charges for expenses incurred or commitments made by NAKS. Captions in these Terms are for convenience only.
- 2. Pricing.** The price for NAKS’ goods, material, equipment, or items (“**Products**”) is complete, and no deductions, credits, or offsets may be made without NAKS’s express written consent. Prices are subject to change and surcharges in the event of cost increases in materials and transportation. All complete component accessory material manufactured by others and furnished with Products such as motors, drives, vibration equipment, controls, or other completely assembled component structures, are subject to adjustment to the price at time of shipment regardless of the date of original order entry.
- 3. Sales and Similar Taxes.** NAKS’ prices do not include sales, use, excise, or similar taxes. Present or future sales, use, excise, or other similar tax applicable to the sale of Products shall be paid by you, unless an acceptable tax exemption certificate is provided to NAKS.
- 4. Payment.** NAKS reserves the right to require full or partial payment in advance of any order if, in NAKS’ judgment, your financial condition does not justify continuation of manufacture or shipment. NAKS may require full or partial payment in advance. Pro-rata payments are due as shipments are made. Each shipment or delivery shall constitute a separate sale, and the default of any shipment or delivery shall constitute a separate sale, and the default of any shipment or delivery shall not vitiate the contract as to other shipments or deliveries. Except as otherwise provided, all payments shall be due within 7 days of receipt of the Products. You shall pay interest on any late payments at the lesser of the rate of 1.5% per month or the highest rate permissible under applicable law, calculated daily and compounded monthly.
- 5. Return Policy – ALL SALES ARE FINAL.** Because we custom manufacture our hoods to each customer’s specifications, ALL SALES ARE FINAL. We may accept the return of non-custom goods at our discretion, but a restocking fee of 30% will apply and all shipping costs are the responsibility of the purchaser or end user. No merchandise may be returned without a Return Goods Authorization (RGA). Items returned for warranty replacement or exchange will not be eligible for credit if not received within 14 days of the issuance of a Return Goods Authorization.
- 6. Delivery.** Shipping and delivery dates are estimates only. No delay in delivery will subject NAKS to any costs, damages or fees for late delivery. Delivery of Products is made F.O.B. point of shipment, unless otherwise stated. NAKS shall not be liable for delay due to causes beyond its reasonable control (i.e., force majeure events). In the event of such a delay, the date of delivery shall be extended for a period equal to the time lost by reason of the delay.
- 7. Changes.** NAKS may make changes, including improvements and additions, in the technical requirements, specifications, designs, materials, packaging, and place of delivery, method of transportation, quantities, or delivery schedules of the Products by notifying you.
- 8. Safety.** The Products may be designed to serve multiple applications. NAKS offers a range of safety equipment, including guards and other devices, as may be required to meet customer specifications. Without exception, NAKS recommends that all orders include applicable safety devices; provided that NAKS disclaims any liability with respect to any specific recommendations for safety equipment for any particular Products. Use of Products ordered without applicable safety devices is your sole responsibility. You warrant that you have

determined and acquired any and all safety devices required for the Products. Weather covers and guards for motor and V-belt drives, couplings, shafts and bearings, along with inlet and outlet screens, are optional accessories noted in the price list.

9. **Title.** Title and right of possession of Products remains with NAKS until all payments (including deferred payments whether evidenced by notes or otherwise) shall have been received to the satisfaction of NAKS and you agree to do all acts necessary to perfect and maintain such title and right in NAKS and not to subject any Products to any liens or encumbrances until such payment is made in full.

10. **Governing Law.** This Order shall be governed by and construed according to the laws of the State of Ohio (excluding the conflict of law provisions thereof). At NAKS' discretion, any action relating directly or indirectly to the Order shall be brought exclusively in the Common Pleas Court of Cuyahoga County, Ohio or the United States District Court for the Northern District of Ohio, Eastern Division, and you irrevocably waive any objection to the jurisdiction of, or venue in, either of these courts and agree that the acceptance of the Order constitutes doing business in the State of Ohio.

11. **Compliance with Law.** You shall comply with all applicable laws, regulations and ordinances related to the Products, and you shall maintain in effect all the licenses, permissions, authorizations, consents and permits that you need with respect to the receipt, use and operation of the Products.

12. **Force Majeure.** NAKS shall not be liable or responsible to you, nor be deemed to have defaulted or breached these Terms, for any failure or delay in fulfilling or performing any terms herein, when and to the extent such failure or delay is caused by or results from acts or circumstances beyond the reasonable control of NAKS including, without limitation, acts of God, flood, fire, earthquake, explosion, governmental actions, war, invasion or hostilities (whether war is declared or not), terrorist threats or acts, riot, or other civil unrest, national emergency, revolution, insurrection, outbreak of disease, lockouts, strikes or other labor disputes (whether or not relating to either party's workforce), or restraints or delays affecting carriers or inability or delay in obtaining supplies of adequate or suitable materials, materials or telecommunication breakdown or power outage.

13. **Waiver.** No waiver by any party of any of the provisions hereof shall be effective unless explicitly set forth in writing and signed by the party so waiving. No failure to exercise, or delay in exercising, any right, remedy, power, or privilege arising from this Agreement shall operate or be construed as a waiver thereof; nor shall any single or partial exercise of any right, remedy, power, or privilege hereunder preclude any other or further exercise thereof or the exercise of any other right, remedy, power, or privilege.

14. **Arbitration.** At NAKS' discretion, any dispute arising under or in connection with any Order may be submitted to binding arbitration administered by the American Arbitration Association under its Commercial Arbitration Rules, and judgment on the award rendered by the arbitrator may be entered in any court having jurisdiction thereof. The dispute shall be resolved by one neutral arbitrator who shall have no affiliation with either you as the buyer or with NAKS and shall be selected by the American Arbitration Association office, and held in, Cleveland, Ohio.

WARNING. NAKS' Products are designed and manufactured to provide reliable performance but they are not guaranteed to be 100% free of defects. Even reliable products will experience occasional failures and this possibility should be recognized by you and all end users. If Products are used in life support ventilation systems where failure could result in loss or injury, you and all end users should provide adequate back-up ventilation, supplementary natural ventilation or failure alarm system, or acknowledge willingness to accept the risk of such loss or injury. **DO NOT USE IN HAZARDOUS ENVIRONMENTS** where fan's electrical system could provide ignition to combustible or flammable materials unless unit is specifically built for hazardous environments. Comply with all local and national safety codes including the National Electrical Code (NEC) and National Fire Protection Act (NFPA).

CAUTION. Guards must be installed when fan is within reach of personnel or within eight (8) feet (2.5 m) of working level or when deemed advisable for safety.

DISCLAIMER. NAKS has made a diligent effort to illustrate and describe the Products accurately in all materials; however, such illustrations and descriptions are for the sole purpose of identification and do not express or imply any warranty.

LIMITED WARRANTY

WARRANTY AND DISCLAIMER. This limited warranty extends to you the original purchaser only with proof of purchase. NAKS warrants that Products shall be free from original defects in workmanship and materials for two

years from date of shipment (except for the warranty periods noted for products listed below), provided the

Products have been properly handled, stored, installed, serviced, maintained and operated.

This warranty shall not apply to Products which have been altered or repaired without NAKS' express authorization, or altered or repaired in any way so as, in NAKS' judgment, to affect performance or reliability, nor which have been improperly installed or subjected to misuse, negligence, or accident, or incorrectly used in combination with other substances. You assume all risks and liability for results of use of all Products.

Evaporative cooling pads are warranted to be free of defects in materials and workmanship for a period of two years from date of shipment provided same have been properly handled, stored, installed, serviced, maintained and operated; and further, not subjected to excessive heat, corrosive agents or chemicals, or mechanical abuse that may cause tearing, crushing or undue deterioration, nor used on a system or in a manner other than that for which it was designed as explained in the Order.

LIMITATION OF REMEDY AND DAMAGES. All claims under this warranty must be made in writing and delivered by U.S. Mail to:

North American Kitchen Solutions

172 Reaser Court

Elyria, OH 44035

Attn: WARRANTY CLAIMS DEPARTMENT

All Product claims must be made within 15 days after discovery of the defect and prior to the expiration of two years from the date of shipment. Claims made beyond that period are barred. Within 30 days after receipt of a timely claim, NAKS shall have the option either to inspect the Product at its location or request its return to NAKS at your expense. NAKS shall replace, or at its option repair, free of charge, any Product it determines to be defective, and it shall ship the repaired or replacement product to you F.O.B. point of shipment; provided, however, if in NAKS' judgment circumstances are such to prohibit repair or replacement to remedy the warranted defects, your sole and exclusive remedy shall be a refund of any part of the invoice price, paid to NAKS, for the defective Product or part.

NAKS is not responsible for the cost of removal of the defective Product or part, damages due to removal, or any expenses incurred in shipping the Product, or the installation of the repaired or replaced Product or part.

The warranties set forth above do not apply to any components, accessories, parts or attachments manufactured by other manufacturers; such being subject to the manufacturer's warranty, if any. To the extent not prohibited by the manufacturer's warranty, NAKS shall pass to you such manufacturer's warranty.

THIS WARRANTY IS IN LIEU OF ALL OTHER WARRANTIES, EXPRESS OR IMPLIED, ARISING BY LAW OR OTHERWISE, INCLUDING WITHOUT LIMITATION THE IMPLIED WARRANTIES OF MERCHANTABILITY AND FITNESS FOR A PARTICULAR PURPOSE, WHICH ARE HEREBY EXPRESSLY DISCLAIMED AND WAIVED. THIS WARRANTY CONSTITUTES NAKS SOLE AND EXCLUSIVE WARRANTY FOR DEFECTIVE GOODS AND YOUR SOLE AND EXCLUSIVE REMEDY FOR DEFECTIVE PRODUCTS.

No employee, agent, dealer, or other person is authorized to give any warranties on behalf of NAKS or to assume for it any other liability in connection with any of its products except in writing and signed by an officer of NAKS.

LIMITATION OF LIABILITY. NAKS' cumulative liability to you and any other persons for all claims in any way relating to or arising out of the Products, including, but not limited to, any cause of action sounding in contract, tort, or strict liability, shall not exceed the total amount of the purchase price paid for those Products which are the subject of any such claim. This limitation of liability is intended to apply without regard to whether other provisions of this agreement have been breached or have proven ineffective even if NAKS has been advised of the possibility of such claims or demands. In no event shall NAKS be liable to you or any other person for any loss of profits or any incidental, special, exemplary, or consequential damages for any claims or demands brought by you or such other persons. BECAUSE SOME JURISDICTIONS DO NOT ALLOW THE EXCLUSION OR LIMITATION OF LIABILITY FOR CONSEQUENTIAL OR INCIDENTAL DAMAGES, THIS LIMITATION MAY NOT APPLY TO YOU.

NAKS' maximum liability to you and to any end user is as set forth above. NAKS makes no warranty to anyone for any products not manufactured by it and shall have no liability for any use or installation of any products

(whether manufactured by NAKS or other manufacturers) not specifically authorized by this sale. You acknowledge various warnings by NAKS regarding the Products and its installation and use. If NAKS incurs any claims, lawsuits, settlements, or expenses (including attorney fees) for any loss, injury, death or property damage including, but not limited to, claims arising out of your or any end user's installation or use of the Products, you agree to indemnify and hold NAKS harmless.

REPLACEMENT PARTS. If replacement parts are ordered, you warrant that the original components in which these replacement parts will be placed are in satisfactory working condition, and when said replacement parts are installed, the resultant installation will operate in a safe manner, at speeds and temperatures for which the original product was purchased.

TECHNICAL ADVICE AND RECOMMENDATIONS, DISCLAIMER. Notwithstanding any past practice or dealings or any custom of the trade, sales shall not include the furnishing of technical advice or assistance or system design. Any such assistance shall be at NAKS' sole option and may be subject to additional charge(s).

NAKS assumes no obligation or liability on account of any recommendations, opinions or advice as to the choice, installation or use of Products. Any such recommendations, opinions or advice are given and shall be accepted at your and the end-user's risk and shall not constitute any warranty or guarantee of such Products or their performance.

2020 © North American Kitchen Solutions, Inc. • 172 Reaser Court, Elyria, OH 44035

Toll Free: (800) 715-1014 customerservice@naksinc.com