

WALK-IN COOLER AND FREEZER MANUAL

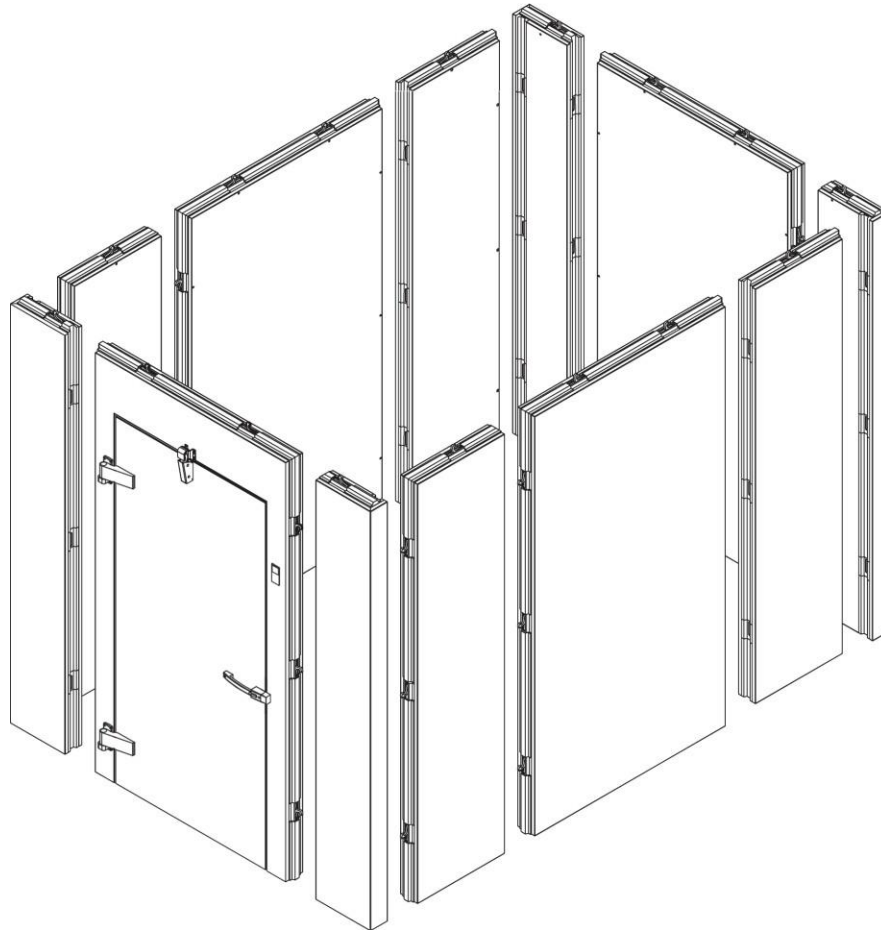

naks NORTH AMERICAN
KITCHEN SOLUTIONS
I N C O R P O R A T E D

Phone: (440) 365-4567
Toll Free: (800) 854-3267
Fax: (440) 365-2100

172 Reaser Ct.
Elyria, OH 44035
sales@naksinc.com

Contents

Safety Instructions	3
Introduction	4
Tools Required	4
Wall Panels	5
Cam Locks	5
Receiving Shipment	6
Site Preparation	6
Floor Installation (if applicable)	7
Vinyl Track Installation (if applicable)	8
Wall Installation	9
Door & Ceiling Installation	10
Hinge Door Adjustment Instructions	11
Door Handle	11
Electrical Installations	12
Plumbing	13
Maintenance	14
Troubleshooting	14
Warranty	15

IMPORTANT SAFETY INSTRUCTIONS



Read and review all instructions and illustrations before installing the structure.

Inspect and report any damage and/or missing parts, before installing. NAKS, Inc, Inc will not be responsible for costs of installing or removing damaged parts.

WARNING: Walking, climbing, or standing on nonpermanent supported panels may result in hazardous conditions including falling. Personnel injury or panel damage may result.

WARNING: For safety purpose only, remove unnecessary adults from the area when installing or servicing the Walk-In.

WARNING: During installation, make sure that the equipment does not exceed floor rating. Note that floor rating might be less than finished product rating until floor installation is complete (for example, until wear surface is field installed). Plywood sheeting should be used to spread the load.

WARNING: Until the walls are made stable by constructing the corners, support extended wall lengths by bracing them from both inside and outside.

Required Personal Protective Equipment for walk-in installation:

- Hard Hat
- Steel-Toed Boots
- Protective Eyewear
- Protective Gloves
- Protective Clothing - i.e., long pants and long sleeve shirts
- Safety Harnesses must be worn when working on elevated surfaces.

WARNING: Improper wiring or lack of proper ground can result in fire, electrical shock, injury or death. Disconnect power to the Walk- In before performing any electrical repairs. Field wiring or electrical repair should be done by a licensed professional electrician. Follow all local building codes and laws for electrical installation.

WARNING: In case of electrical fire, disconnect the power supply. Do not use water on electrical fires. Smother the fire with an extinguisher rated for C-class fires.

Introduction

Thank you for purchasing a walk-in cooler or freezer from NAKS, Inc, Inc. As a company, we are proud to say that all of our products are designed and manufactured to the needs and standards of our customers. This manual contains important information and instructions for installing, using, and servicing NAKS, Inc walk-ins. Although no single set of directions will apply to every situation, some basic instructions do apply. Please read all these documents carefully before installing or servicing your walk-in in order to make sure your walk-in is operating safely and efficiently. For a special installation please feel free to contact us.

A Packing List and Assembly Drawings are included with the shipment that identifies every item shipped with the corresponding panel numbers and indicates how it is assembled. Panels are stacked in the best way possible to minimize the risk of shipment damage. They are not stacked in order of panel numbers.

Tools Required

Minimum required tool set includes:

- Tape measure
- Hammer
- Chalk line
- Drill and Electric screwdriver
- Pry-bar
- 4 ft Level
- Cam lock wrench (provided)

Protective Equipment:

- Protective Eyewear
- Gloves
- Steel-Toed Boots
- Hard Hat

Wall Panels

All panels consist of 4 inches of thermal resistant insulated foam with a 24-gauge stucco embossed galvalume finish on the exterior. The panels have male and female grooves with gaskets, resulting in an air-tight seal. Panels are provided with male and female cam-locking device sets that are positioned to be aligned with each panel. There is a hole located in the interior metal panel that allows you to have access to the male lock.

Cam Locks

- Make sure all cam-lock locking arms are in the open position.
- Push panels together and insert the hex wrench (provided) through the hole and firmly engage with hex opening.
- Turn wrench 1/4 clockwise, this will engage the locking arm over the locking pin.
- Continue to turn wrench for 1/2 turn or until panels are fastened together tightly.
- Do not over tighten cam locks as this can cause the cam to separate from the panel.
- Plugs have been provided to cover the holes for the wrench.

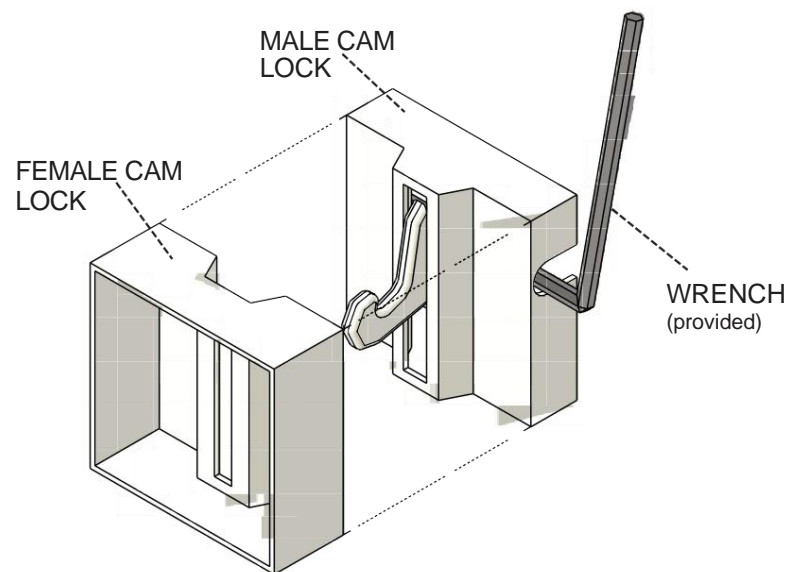
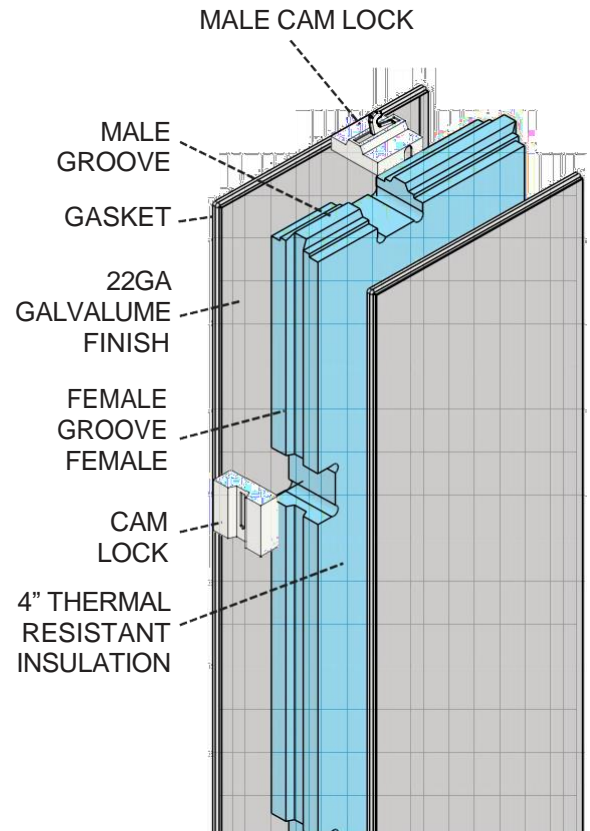
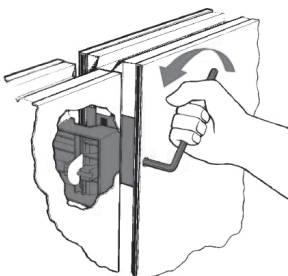

Receiving Shipment

- Check the shipment carefully.
- Account for all items listed and inspect each container for damage.
- If concealed damage is discovered, immediately report issues to both the trucking company and NAKS, Inc, Inc. to file a claim.
- When handling panels keep them flat to prevent denting and avoid resting them on their corner edges.
- Always have another person help while handing the panels.

Site Preparation

- Chalk the perimeter outline of the structure to ensure that there is proper space for your unit.
- If the Walk-in is adjacent to a building wall, allow a minimum of 2-inch clearance. Also allow a minimum 2-inch clearance for ceiling height. Refer to refrigeration equipment space requirements for additional clearance.
- Measure from corner to corner to make sure it is square.
- The entire floor area must be leveled from this highest point. Floor leveling can be done with wooden shims.

⚠ CAUTION: Please be sure the area is free of debris and swept clean. The floor **MUST** be leveled.

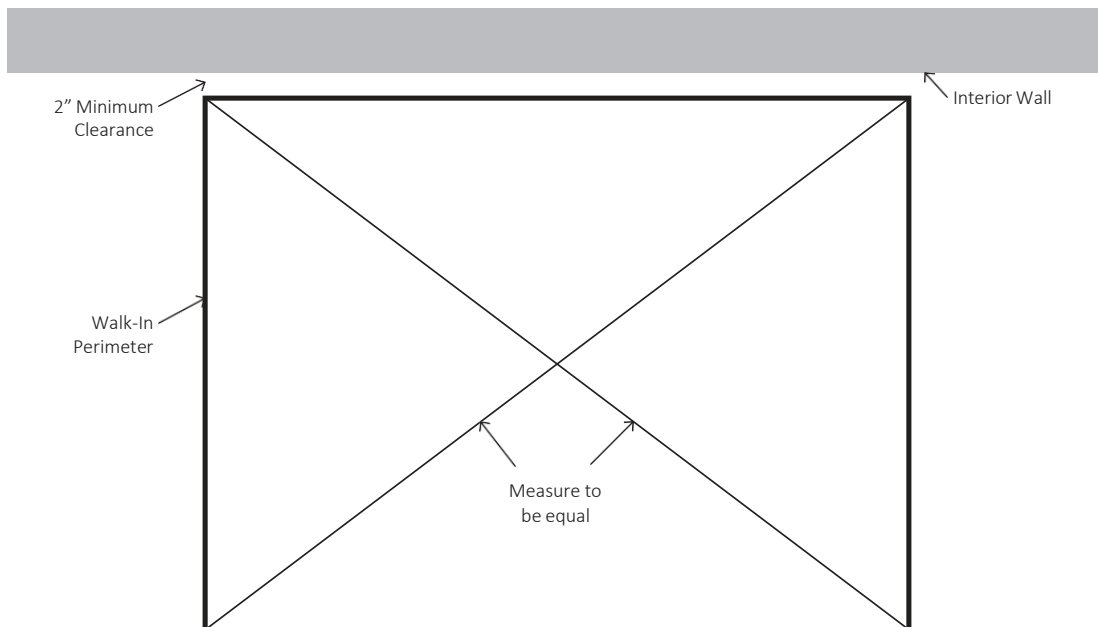

Floor Installation (if applicable)

Depending on your walk-in unit, it may be supplied with or without floor panels. If your unit is floorless, proceed to the Vinyl Track Installation Section.

- Using your assembly drawings of your walk-in, lay out all of the floor panels in the correct order. Be sure the panels level in length and width.
- After making sure the edges are flush, tighten the locks together, making sure the panels are evenly aligned and secured together.
- Follow this procedure until the last panel is in place. The last panel will be near the door. Refer to assembly drawings provided.
- As you assemble your floor, check to make sure that existing floor is leveled, and the chalk line is followed.

⚠ IMPORTANT: To ensure proper installation, the floor must be perfectly leveled. If not, the panels will not seal properly.

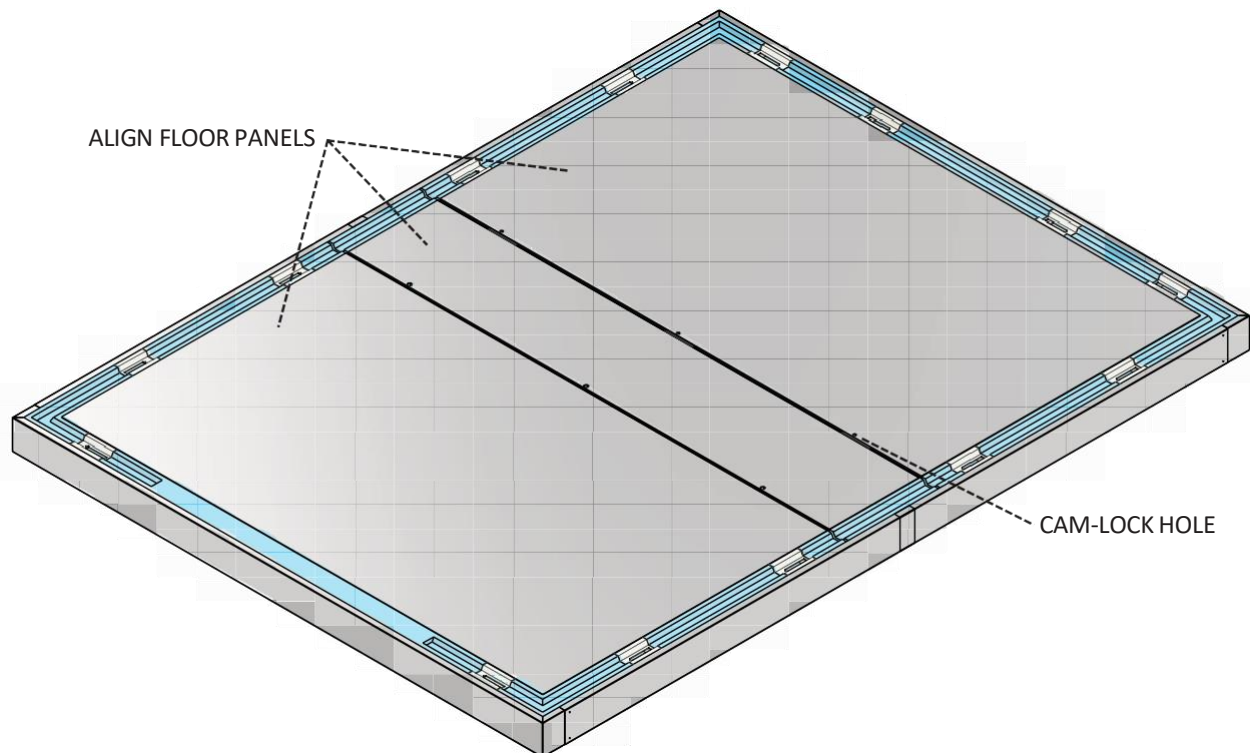

Vinyl Track Installation (if applicable)

Floorless walk-in units are provided with a vinyl track that runs under the panels for stability in your unit.

- Using the outline chalk line perimeter, create an additional perimeter to mark the interior outline, 4 1/2 inches from the exterior outline.
- Make sure the diagonals are the same measurement.
- Lay two lines of silicone caulk within the 4-inch vinyl track location. Put one line of caulk on each inside edge of the track. (Top along the panel and bottom along the floor.)
- Lay out all of the vinyl track in the correct placement. Make sure the corners meet at 45° angle.
- As you assemble your floor, check to make sure that the chalk line is followed.
- If the existing surface is not level, find the highest point of the vinyl and add wooden shims until the vinyl track is leveled.

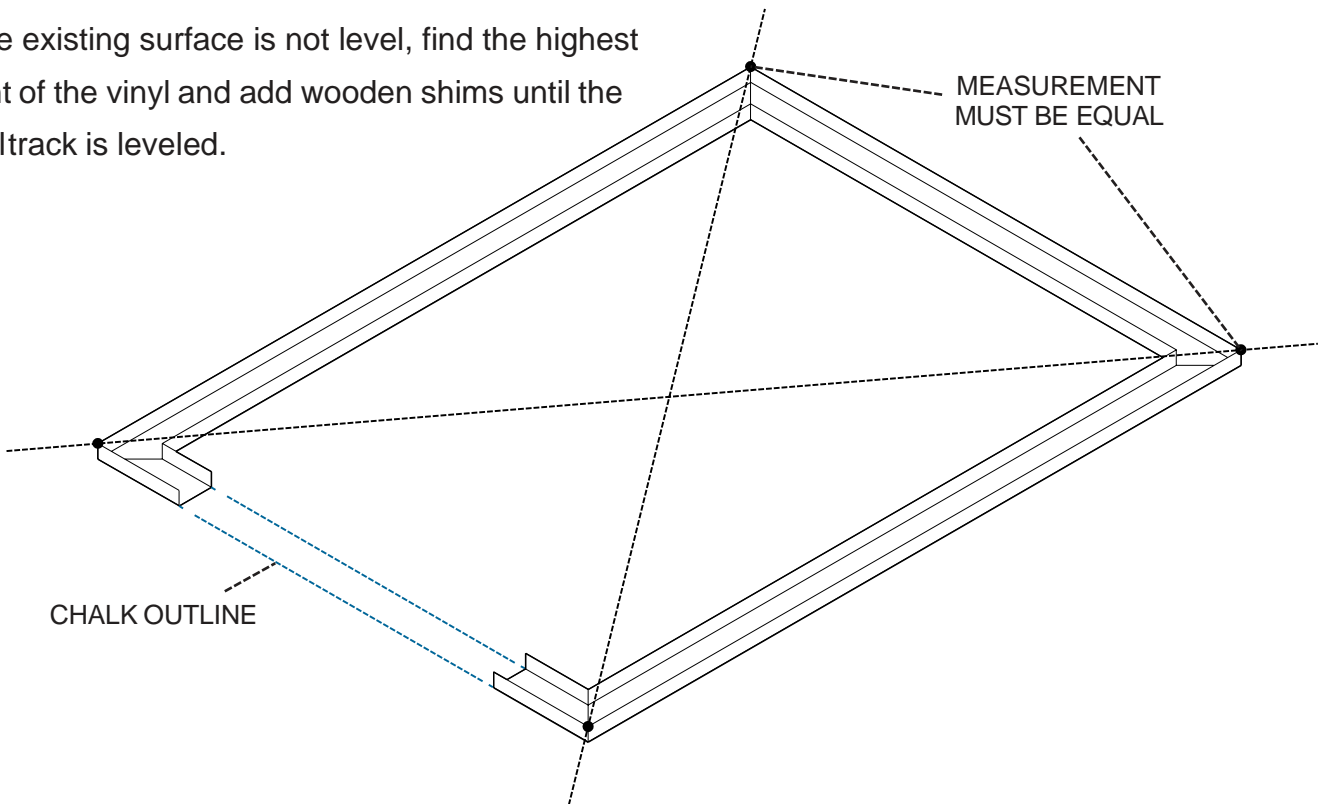
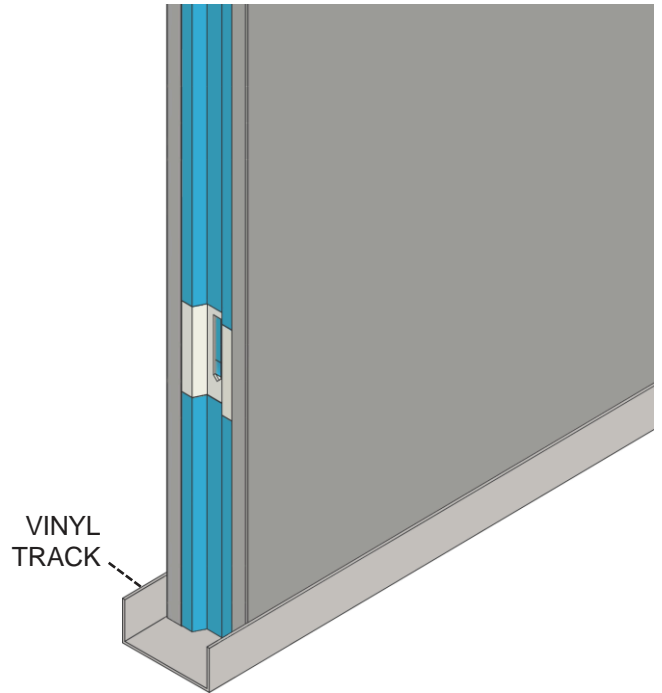

Wall Installation

Before placing the wall panels, make sure all of the cams are in the open position. Using your assembly drawings, lay out all of the panels in the correct order. Start by placing the # 1 panel, then add the adjacent panel to it. Lock them together. As all the panel are assembled on a track or floor, tighten the cam locks with one another and make sure the panels are flush on the top and sides. Do not force a cam to lock. If it does not lock, check to see if the panels are firmly together. Do not lock the panels to the floor until all wall and ceiling panels are locked together. Make sure the holes for the cam locks are facing inside of the unit. If you notice that the floor is uneven, adjustments must be made to ensure wall panels are flush at the top.

⚠ IMPORTANT: Refer to your assembly drawings to see where each panel goes. Each panel must be installed in the specific area as directed.



CORRECT INSTALLATION

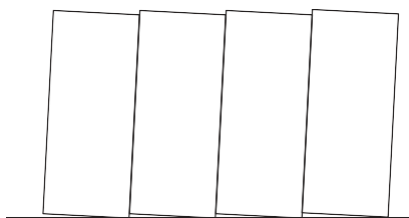

INCORRECT INSTALLATION

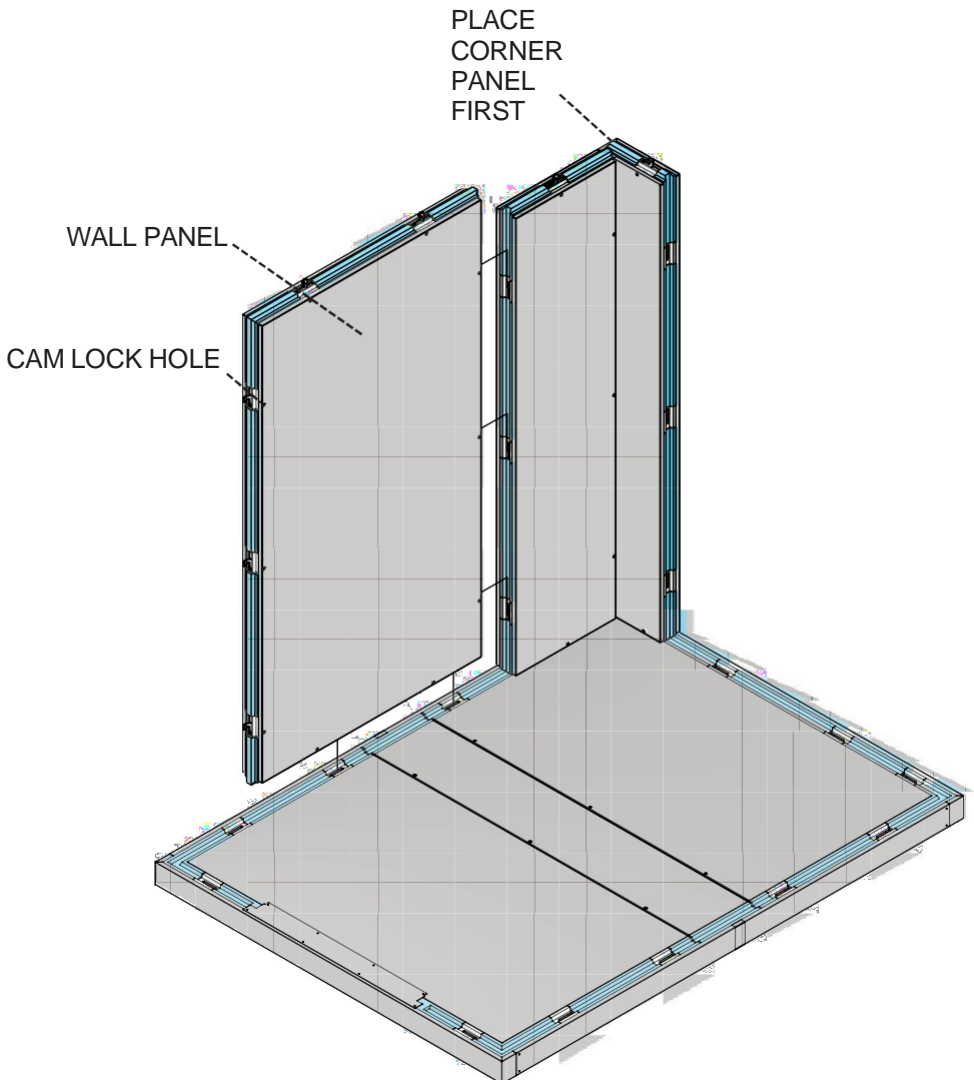

Door & Ceiling Installation

The door panel should be placed like any other wall panel. The last wall panel installed should be a panel adjacent to the door. Follow the assembly drawings to see which panel is the last to be placed.

Once you have the wall panels and door panel installed, locate the roof panel that is located at the end of the unit. Make the roof flush with the sides of the wall panels. Place the second panel on top and align the panel with the sides. Lock the two roof panels into place. As the roof panels are being placed, lightly lock the roof panels to the wall panels.

After the roof panels are in place, lock them tightly to the wall panels. Then lock the wall panels to the floor panels, if applicable.

After all of the roof and wall panels are secured in place, check that all of the cam locks are locked in tightly. The door and frame should be flush around the perimeter. Clean panels of any dirt, metal shavings or other debris by using a non-abrasive drycloth.

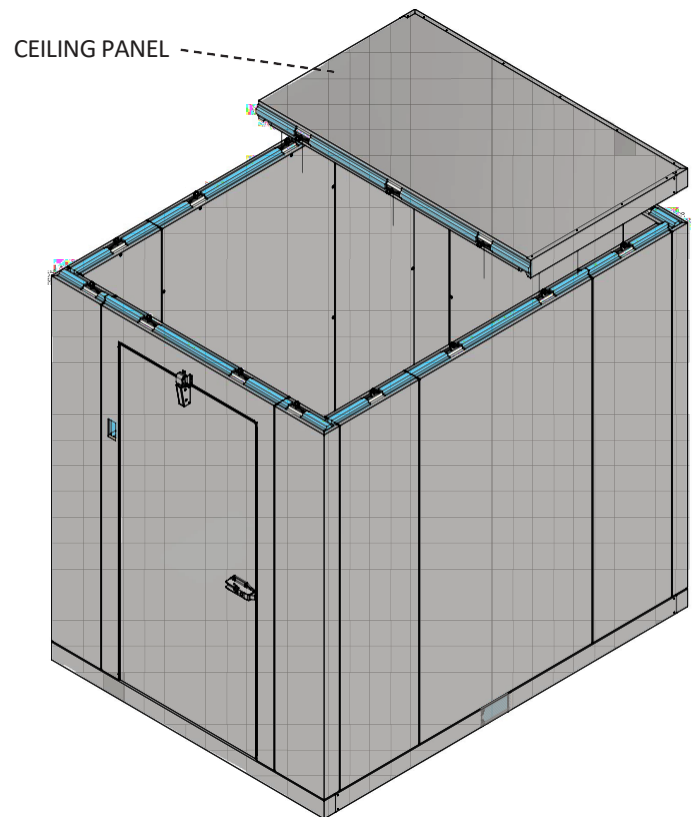
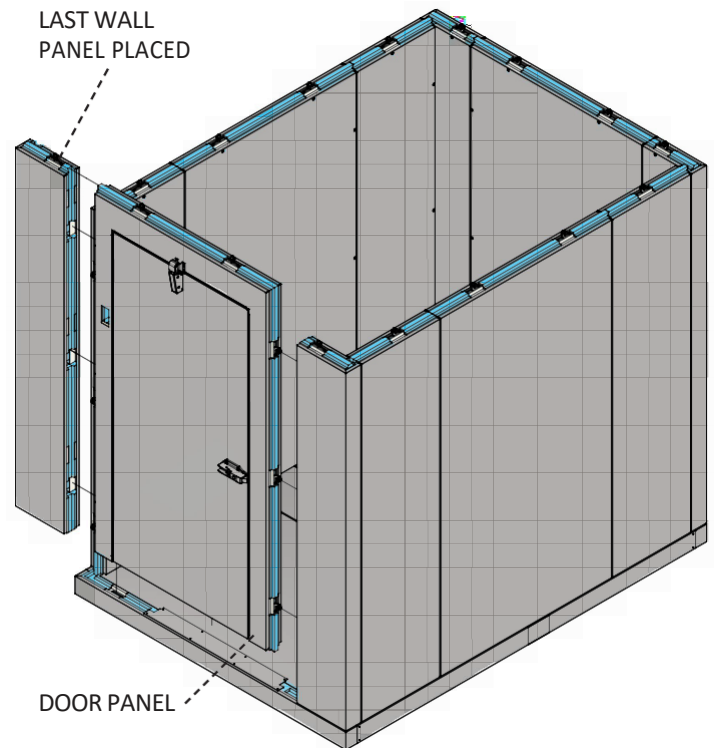

Hinge Door Adjustment Instructions

1. Remove access cover by depressing point "A" and pulling it outward.
2. Loosen 4 mounting screws on each strap, but do not remove screw.
3. Open door to break seal with magnetic gasket.
4. Adjust tip of door up by turning top hinge adjustment screw clockwise (opposite for Left Hand Door) and the bottom hinge adjustment screw counter-clockwise (opposite for Left Hand Door) so door spacing is even.
5. Tighten 4 mounting screws on each hinge.
6. Replace cover by inserting point "A" first.

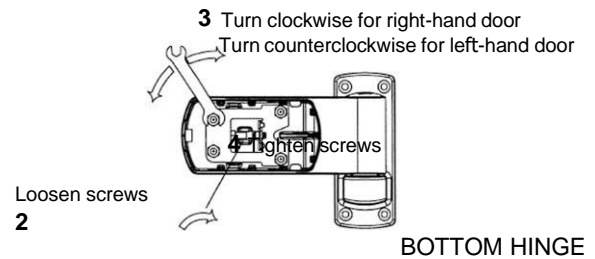
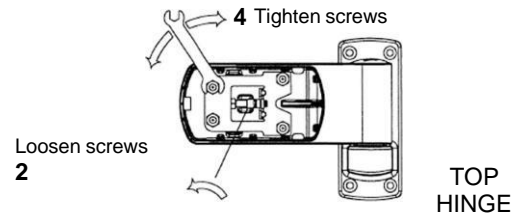
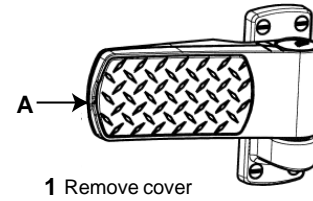

3 Turn clockwise for right-hand door
Turn counterclockwise for left-hand door

Door Handle

- Easy to operate, notch slides to lock
- Door easily pulls or pushes open when it's unlocked
- Locking mechanism is located on the outside of the unit to resist freeze-up
- Located on the inside of the unit, there is a glow-in-the-dark release knob to prevent lock-ins.



Electrical Installations

- Refer to wiring diagram below for installation all 115V power.
- For refrigeration equipment, refer to electrical instructions associated with the equipment. Provide separate circuits from the refrigeration and electrical shown below.
- A wiring shall be copper conductors only suitable for at least 750C/1670F.

A three-wire, three-phase, 220-240 V permanently connected appliance intended for connection to branch circuit conductors operating at 150V or less to ground shall be marked where visible during installation with the following or equivalent: "Do not connect to a circuit operating at more than 150V to ground." The marking shall identify the leads or terminals that are to be supplied by circuit conductors of 150V or less to ground.

CAUTION: Risk of electric shock.

CAUTION: This section should be done by a qualified electrician.

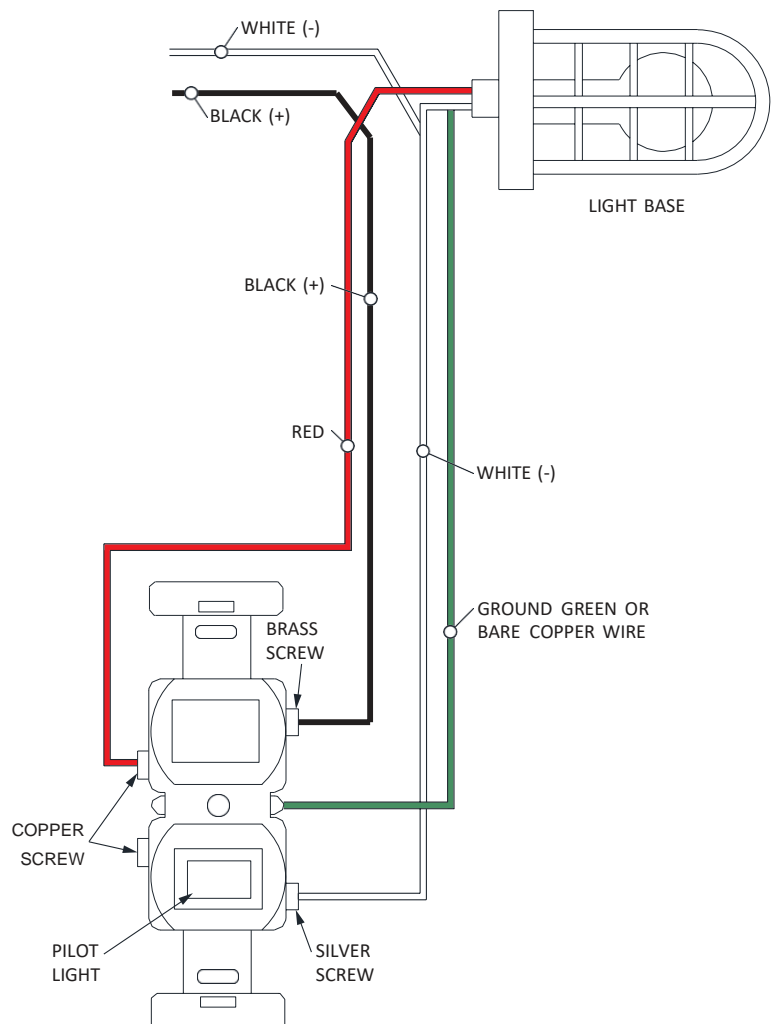

Plumbing

Condensate piping from the evaporator shall be routed outside the walk-in cooler/freezer and continued to an approved floor drain/floor sink. Piping to be sized and routed in accordance with local building codes and shall maintain required slope and insulation to prevent freezing where applicable. Drill completely through the panel wall to route condensate outside the walk-in. Protect the piping at this location with a bushing and completely seal the penetration airtight. (Failure to seal the penetration airtight can result in condensation forming along the penetration on the interior and exterior of the cooler.)

All penetrations through the walk-in wall must be sealed airtight.

Maintenance

It is important for proper upkeep of the walk-in unit to ensure many years of service. Having the walk-in floors wet can be slippery and hazardous.

The following tasks should be performed:

- All surfaces, magnetic door gasket and door gasket should be cleaned frequently with warm water and mild detergents and rinse thoroughly with hot water. Avoid using excessive water.
- Keep all walkway surfaces clean and free of spilled liquids and food particles.
- Lubricate door hinge pivots, latches and inside releases at least once a year.
- Check all hardware and fasteners regularly to be sure that they are firmly anchored.
- Inspect refrigeration equipment frequently for proper functioning of evaporators, drain pan heaters, defrost controls and drains line heaters.

Troubleshooting

Frost or Condensation around door

This may indicate that there is a poor gasket seal or a defective heat cable. Check the door alignment and see if the hinges are adjusted properly. Check for a constant power source to the heat cable

Cam lock not engaging

Make sure wall panels are flush on sides and top, so cams are lined up properly. Reset cam by turning it counterclockwise until it resets. Then relock cam.

Cam wrench is binding in cam hole

Only insert the wrench far enough to catch the mechanism. Make sure you are inserting the tapered end of the wrench in the hole.

Ceiling panels won't lock into walls

If walls have been locked to floor, unlock walls from the floor, lock ceiling panels down to walls and relock wall to floor.

Ceiling overhangs walls

If walls are racked at the top, loosen wall cams and adjust walls so the tops of the walls line up. If walls are level at the top, loosen corner wall panel and bump out wall panel to line up with outer edge of ceiling. Lock ceiling to wall and re-lock corner seam.

If none of these solutions help, feel free to contact us at
(800) 854-3267

TERMS AND CONDITIONS OF SALE

THESE TERMS AND CONDITIONS OF SALE (“*TERMS*”) CONTAIN VERY IMPORTANT INFORMATION REGARDING YOUR PURCHASE, AS WELL AS CONDITIONS, LIMITATIONS, AND EXCLUSIONS THAT APPLY TO YOU AND YOUR PURCHASE. PLEASE READ THEM CAREFULLY. YOUR PURCHASE IS EXPRESSLY LIMITED TO AND MADE CONDITIONAL UPON THE EXCLUSIVITY OF THESE TERMS. ANY PROPOSAL FOR DIFFERENT TERMS OR ANY ATTEMPT TO VARY, IN ANY DEGREE, ANY OF THESE TERMS IS EXPRESSLY REJECTED.

1. **Acceptance.** These Terms govern any purchase made from North American Kitchen Solutions, Inc. (“*North American Kitchen Solutions*”). These Terms, the Manual in which they are contained, installation and maintenance instructions, the applicable invoice, and any documents incorporated or referred to herein or therein, including any future paper or electronic releases issued by North American Kitchen Solutions, constitute the “Order.” The Order is the entire contract between you, the buyer, and North American Kitchen Solutions, the seller, for products purchased from North American Kitchen Solutions. These Terms apply to the Order unless expressly modified or waived in writing by an officer of North American Kitchen Solutions. An Order may only be cancelled by you upon payment of reasonable cancellation charges for expenses incurred or commitments made by North American Kitchen Solutions. Captions in these Terms are for convenience only.
2. **Pricing.** The price for North American Kitchen Solutions’ goods, material, equipment, or items (“*Products*”) is complete, and no deductions, credits, or offsets may be made without North American Kitchen Solutions’ express written consent. Prices are subject to change and surcharges in the event of cost increases in materials and transportation. All complete component accessory material manufactured by others and furnished with Products such as motors, drives, vibration equipment, controls, or other completely assembled component structures, are subject to adjustment to the price at time of shipment regardless of the date of original order entry.
3. **Sales and Similar Taxes.** North American Kitchen Solutions’ prices do not include sales, use, excise, or similar taxes. Present or future sales, use, excise, or other similar tax applicable to the sale of Products shall be paid you, unless an acceptable tax exemption certificate is provided to North American Kitchen Solutions.
4. **Payment.** North American Kitchen Solutions reserves the right to require full or partial payment in advance of any order. Pro-rata payments are due as shipments are made. Each shipment or delivery shall constitute a separate sale, and the default of any shipment or delivery shall constitute a separate sale, and the default of any shipment or delivery shall not vitiate the contract as to other shipments or deliveries.
5. **Return Policy – ALL SALES ARE FINAL.** Because we custom manufacture our hoods to each customer’s specifications, ALL SALES ARE FINAL. We may accept the return of non-custom goods at our discretion, but a restocking fee of 30% will apply and all shipping costs are the responsibility of the purchaser or end user. No merchandise may be returned without a Return Goods Authorization (RGA). Items returned for warranty replacement or exchange will not be eligible for credit if not received within 14 days of the issuance of a Return Goods Authorization.
6. **Free Shipping.** Free shipping offers are limited to standard shipping to the 48 contiguous United States.
7. **Delivery** - Shipping and delivery dates are estimates only. No delay in delivery will subject North American Kitchen Solutions to any costs, damages or fees for late delivery. Delivery of Products is made F.O.B. point of shipment, unless otherwise stated. North American Kitchen Solutions shall not be liable for delay due to causes beyond its reasonable control (i.e., force majeure events). In the event of such a delay, the date of delivery shall be extended for a period equal to the time lost by reason of the delay.
8. **Changes.** North American Kitchen Solutions may make changes, including improvements and additions, in the technical requirements, specifications, designs, materials, packaging, and place of

delivery, method of transportation, quantities, or delivery schedules of the Products by notifying you.

9. **Safety.** The Products may be designed to serve multiple applications. North American Kitchen Solutions offers a range of safety equipment, including guards and other devices, as may be required to meet customer specifications. Without exception, North American Kitchen Solutions recommends that all orders include applicable safety devices. Use of Products ordered without applicable safety devices are your sole responsibility. You warrant that you have determined and acquired any and all safety devices required for the Products. Weather covers and guards for motor and V-belt drives, couplings, shafts and bearings, along with inlet and outlet screens, are optional accessories noted in the price list.

10. **Title.** Title and right of possession of Products remains with North American Kitchen Solutions until all payments (including deferred payments whether evidenced by notes or otherwise) shall have been received to the satisfaction of North American Kitchen Solutions and you agree to do all acts necessary to perfect and maintain such title and right in North American Kitchen Solutions and not to subject any Products to any liens or encumbrances until such payment is made in full.

11. **Governing Law.** This Order shall be governed by and construed according to the laws of the State of Ohio (excluding the conflict of law provisions thereof). At North American Kitchen Solutions' discretion, any action relating directly or indirectly to the Order shall be brought exclusively in the Common Pleas Court of Cuyahoga County, Ohio or the United States District Court for the Northern District of Ohio, Eastern Division, and you irrevocably waive any objection to the jurisdiction of, or venue in, either of these courts and agree that the acceptance of the Order constitutes doing business in the State of Ohio.

12. **Compliance with Law.** You shall comply with all applicable laws, regulations and ordinances related to the Products, and you shall maintain in effect all the licenses, permissions, authorizations, consents and permits that you need with respect to the receipt, use and operation of the Products.

13. **Force Majeure.** NAKS shall not be liable or responsible to you, nor be deemed to have defaulted or breached these Terms, for any failure or delay in fulfilling or performing any terms herein, when and to the extent such failure or delay is caused by or results from acts or circumstances beyond the reasonable control of NAKS including, without limitation, acts of God, flood, fire, earthquake, explosion, governmental actions, war, invasion or hostilities (whether war is declared or not), terrorist threats or acts, riot, or other civil unrest, national emergency, revolution, insurrection, outbreak of disease, lockouts, strikes or other labor disputes (whether or not relating to either party's workforce), or restraints or delays affecting carriers or inability or delay in obtaining supplies of adequate or suitable materials, materials or telecommunication breakdown or power outage.

14. **Waiver.** No waiver by any party of any of the provisions hereof shall be effective unless explicitly set forth in writing and signed by the party so waiving. No failure to exercise, or delay in exercising, any right, remedy, power, or privilege arising from this Agreement shall operate or be construed as a waiver thereof; nor shall any single or partial exercise of any right, remedy, power, or privilege hereunder preclude any other or further exercise thereof or the exercise of any other right, remedy, power, or privilege.

15. **Arbitration.** At North American Kitchen Solutions' discretion, any dispute arising under or in connection with any Order may be submitted to binding arbitration administered by the American Arbitration Association under its Commercial Arbitration Rules, and judgment on the award rendered by the arbitrator may be entered in any court having jurisdiction thereof. The dispute shall be resolved by one neutral arbitrator who shall have no affiliation with either you as the buyer or with North American Kitchen Solutions and shall be selected by the American Arbitration Association office, and held in, Cleveland, Ohio.

WARNING. North American Kitchen Solutions' Products are designed and manufactured to provide reliable performance but they are not guaranteed to be 100% free of defects. Even reliable products will experience occasional failures and this possibility should be recognized by the buyer and all end users. If Products are used in life support ventilation systems where failure could result in loss or injury, the buyer and all end users should provide adequate back-up ventilation, supplementary natural ventilation or

failure alarm system, or acknowledge willingness to accept the risk of such loss or injury. **DO NOT USE IN HAZARDOUS ENVIRONMENTS** where a fan's electrical system could provide ignition to combustible or flammable materials unless unit is specifically built for hazardous environments. Comply with all local and national safety codes including the National Electrical Code (NEC) and National Fire Protection Act (NFPA).

CAUTION. Guards must be installed when fan is within reach of personnel or within eight (8) feet (2.5 m) of working level or when deemed advisable for safety.

DISCLAIMER. North American Kitchen Solutions has made a diligent effort to illustrate and describe the Products accurately in all materials; however, such illustrations and descriptions are for the sole purpose of identification and do not express or imply any warranty.

LIMITED WARRANTY

WARRANTY AND DISCLAIMER. This limited warranty extends to you the original purchaser only with proof of purchase. North American Kitchen Solutions warrants that Products shall be free from original defects in workmanship and materials for one year from date of shipment (except for the warranty periods noted for products listed below), provided the Products have been properly handled, stored, installed, serviced, maintained and operated. This warranty shall not apply to Products which have been altered or repaired without North American Kitchen Solutions' express authorization, or altered or repaired in any way so as, in North American Kitchen Solutions' judgment, to affect performance or reliability, nor which have been improperly installed or subjected to misuse, negligence, or accident, or incorrectly used in combination with other substances. You assume all risks and liability for results of use of all Products.

Evaporative cooling pads are warranted to be free of defects in materials and workmanship for a period of one year from date of shipment provided same have been properly handled, stored, installed, serviced, maintained and operated; and further, not subjected to excessive heat, corrosive agents or chemicals, or mechanical abuse that may cause tearing, crushing or undue deterioration, nor used on a system or in a manner other than that for which it was designed as explained in the Order.

LIMITATION OF REMEDY AND DAMAGES. All claims under this warranty must be made in writing and delivered by U.S. Mail to:

North American Kitchen Solutions, Inc.
172 Reaser Court
Elyria, OH 44035
Attn: WARRANTY CLAIMS DEPARTMENT

All Product claims must be made within 15 days after discovery of the defect and prior to the expiration of one year from the date of shipment. Claims made beyond that period are barred. Within 30 days after receipt of a timely claim, North American Kitchen Solutions shall have the option either to inspect the Product at its location or request its return to North American Kitchen Solutions at your expense. North American Kitchen Solutions shall replace, or at its option repair, free of charge, any Product it determines to be defective, and it shall ship the repaired or replacement product to you F.O.B. point of shipment; provided, however, if in North American Kitchen Solutions' judgment circumstances are such to prohibit repair or replacement to remedy the warranted defects, your sole and exclusive remedy shall be a refund of any part of the invoice price, paid to North American Kitchen Solutions, for the defective Product or part.

North American Kitchen Solutions is not responsible for the cost of removal of the defective Product or part, damages due to removal, or any expenses incurred in shipping the Product, or the installation of the repaired or replaced Product or part.

The warranties set forth above do not apply to any components, accessories, parts or attachments manufactured by other manufacturers; such being subject to the manufacturer's warranty, if any. To the

extent not prohibited by the manufacturer's warranty, North American Kitchen Solutions shall pass to you such manufacturer's warranty.

THIS WARRANTY IS IN LIEU OF ALL OTHER WARRANTIES, EXPRESS OR IMPLIED, ARISING BY LAW OR OTHERWISE, INCLUDING WITHOUT LIMITATION THE IMPLIED WARRANTIES OF MERCHANTABILITY AND FITNESS FOR A PARTICULAR PURPOSE, WHICH ARE HEREBY EXPRESSLY DISCLAIMED AND WAIVED. THIS WARRANTY CONSTITUTES NORTH AMERICAN KITCHEN SOLUTIONS'S SOLE AND EXCLUSIVE WARRANTY FOR DEFECTIVE GOODS AND PURCHASER'S SOLE AND EXCLUSIVE REMEDY FOR DEFECTIVE PRODUCTS.

No employee, agent, dealer, or other person is authorized to give any warranties on behalf of North American Kitchen Solutions or to assume for it any other liability in connection with any of its products except in writing and signed by an officer of North American Kitchen Solutions.

LIMITATION OF LIABILITY. North American Kitchen Solutions' cumulative liability to you and any other persons for all claims in any way relating to or arising out of the Products, including, but not limited to, any cause of action sounding in contract, tort, or strict liability, shall not exceed the total amount of the purchase price paid for those Products which are the subject of any such claim. This limitation of liability is intended to apply without regard to whether other provisions of this agreement have been breached or have proven ineffective even if North American Kitchen Solutions has been advised of the possibility of such claims or demands. In no event shall North American Kitchen Solutions be liable to you or any other person for any loss of profits or any incidental, special, exemplary, or consequential damages for any claims or demands brought by you or such other persons. BECAUSE SOME JURISDICTIONS DO NOT ALLOW THE EXCLUSION OR LIMITATION OF LIABILITY FOR CONSEQUENTIAL OR INCIDENTAL DAMAGES, THIS LIMITATION MAY NOT APPLY TO YOU.

North American Kitchen Solutions' maximum liability to you and to any end user is as set forth above. North American Kitchen Solutions makes no warranty to anyone for any products not manufactured by it and shall have no liability for any use or installation of any products (whether manufactured by North American Kitchen Solutions or other manufacturers) not specifically authorized by this sale. You acknowledge various warnings by North American Kitchen Solutions regarding the Products and its installation and use. If North American Kitchen Solutions incurs any claims, lawsuits, settlements, or expenses (including attorney fees) for any loss, injury, death or property damage including, but not limited to, claims arising out of your or any end user's installation or use of the Products, you agree to indemnify and hold North American Kitchen Solutions harmless.

REPLACEMENT PARTS. If replacement parts are ordered, purchaser warrants that the original components in which these replacement parts will be placed are in satisfactory working condition, and when said replacement parts are installed, the resultant installation will operate in a safe manner, at speeds and temperatures for which the original product was purchased.

TECHNICAL ADVICE AND RECOMMENDATIONS, DISCLAIMER. Notwithstanding any past practice or dealings or any custom of the trade, sales shall not include the furnishing of technical advice or assistance or system design. Any such assistance shall be at North American Kitchen Solutions' sole option and may be subject to additional charge(s).

North American Kitchen Solutions assumes no obligation or liability on account of any recommendations, opinions or advice as to the choice, installation or use of Products. Any such recommendations, opinions or advice are given and shall be accepted at your and the end-user's risk and shall not constitute any warranty or guarantee of such Products or their performance.

2021 © North American Kitchen Solutions, Inc. • 172 Reaser Court, Elyria, OH 44035

Toll Free: (800) 715-1014

customerservice@naksinc.co