

Gas-Fired Tempered Make-Up Air Unit

Model:

T1-1200-115-1

1-Phase, 115V, 0.50 HP, Belt driven with Motorized Damper and 10-8" Blower. MAX 2,200 CFM

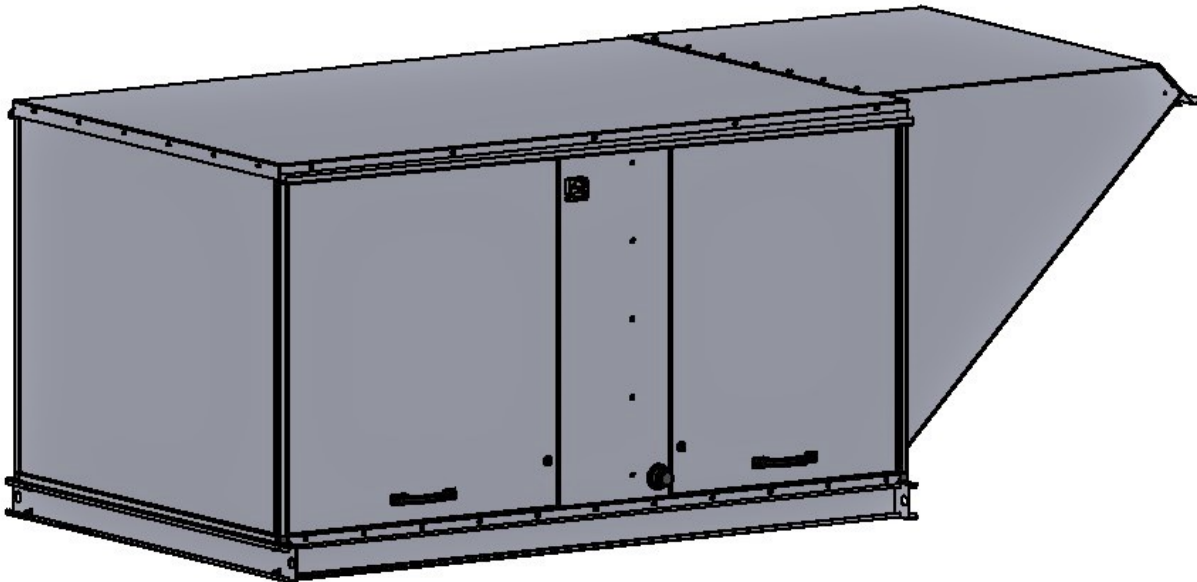



T1-HOX Direct Fired (350 lbs.)

Supply Motor:

Model EL11304, 0.50 HP, 115-1-60, 4.70 FLA, ODP (Open Drip Proof)

Supply Motor Pulleys:

<u>Part Type</u>	<u>Qty</u>	<u>Browning #</u>	<u>Turns Out</u>
Blower Pulley	1	MA38 x 3/4	
Motor Pulley	1	1VP34 x 5/8	4.0

Burner:

Min Output BTU: 18,000 BTU/Hr
Max Output BTU: 375,000 BTU/Hr
Size: 6" long
Gas Type: Natural

Supply Performance:

Volume: 1200 cfm Volume Range: 800-2200 cfm
RPM: 1044
TS: 3041 ft/min
SP: 1.15" w.g.
0.50" Ext. + 0.40" Int. + 0.25" Opt.
BHP: 0.38

Heating Schedule:

Altitude: 0'
Winter Entering Air Dry Bulb Temp: 0°F
Temp Rise: 100°F
Output BTU: 123,000
Input BTU: 134,000
BTUs BASED OFF STANDARD AIR DENSITY

Supply Installation Information:

Gas Inlet Pressure: 7 in. w.c. - 14 in. w.c.
Insurance: FM/ETL
Unit Main Input: 7.88 Amps MCA, 12 Amps MOP, 115 V, 14 AWG Wire Min.
Supply Unit Voltage: 115v-1ph-60hz

Construction Features

Housing constructed of heavy-duty unpainted G90 galvanized steel • Forward curved centrifugal blower wheel • Vibration isolation • Adjustable drive assemblies • Adjustable motor mount • Ball bearing motors • Heavy duty, pre-lubricated bearings L10 rated for 100,000 hours of operation • Static resistant belts • Service doors on both sides • Horizontal & down discharge • Large intake area ensures low pressure drop across unit • Electronic Burner Profiler System automatically adjusts for any airflow - no manual setting required! • Weatherproof safety disconnect switch • Modular design provides design flexibility • Fully insulated casing

Blower:

10-8" forward curved, centrifugal blower. Permanently lubricated ball bearings. Galvanized finish. 3/4" shaft. 3,000 max. RPM. Used in heated and non-heated supply fans.

Temp Control:

Maxitrol Series 14 • 40-90°F Discharge Temp Control • Field Wired On/Off Start Command; Temperature set point dial @ main/unit panel.

Intake:

Sloped Filtered Intake for T1 Modular Heater. 23" Wide x 21" Long x 24" High. Includes 2" MV EZ Kleen Metal Mesh Filters.

Filters:

1x MV EZ Kleen Metal Mesh Filter. 25"x 20"x 2" Used for heater and supply fan intakes.

Selected Options:

- Motorized Inlet Damper 16"W x 16"H for T1 Modular Heating Units w/Extended Shaft, Standard Galvanized Construction, 3/4" Rear Flange, LMX24-3-S Belimo Actuator Included (with end switch)
- Low Fire Start. Allows the burner circuit to energize when the modulation control is in a low fire position.

PROPRIETARY

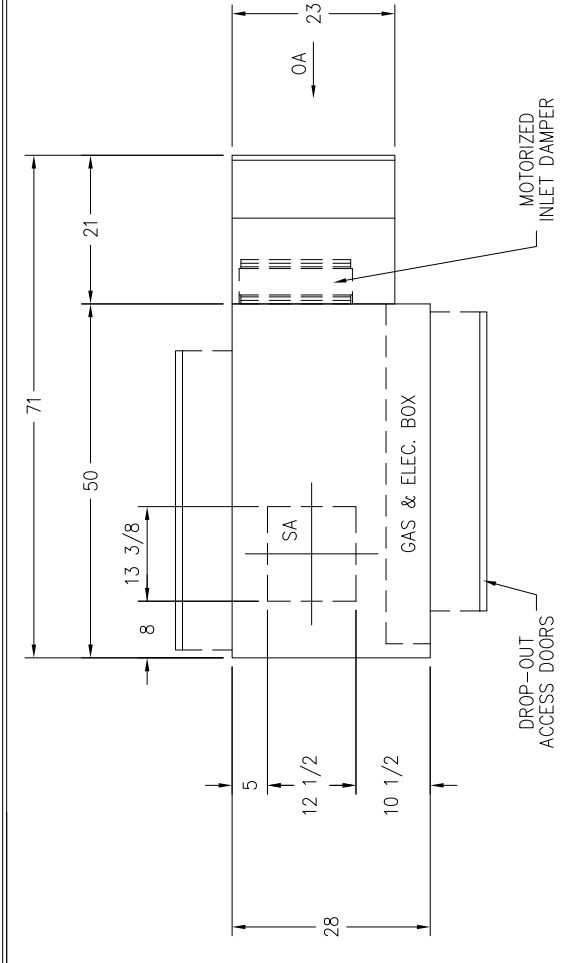

PLAN VIEW

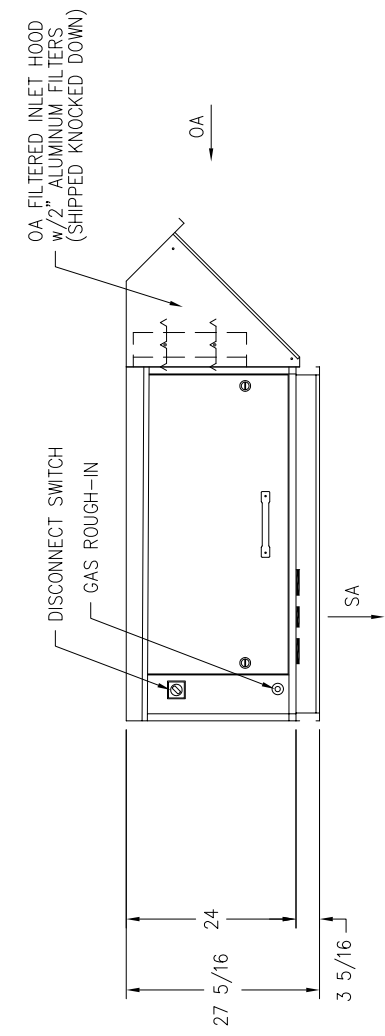

CONTROLS SIDE VIEW

PERFORMANCE & SPECIFICATIONS		
MODEL:	T1-HOX	QUANTITY: 1
CONTROLS SIDE:	LEFT (STD)	DISCHARGE: BOTTOM
1,200 CFM @ 0.50" WC ESP (1.15" WC TSP) @ 0' ELEV.		
BLOWER SIZE:	G10-8 CANARM/DELHI	
MOTOR HORSEPOWER:	0.50 HP	
MOTOR TYPE:	STD-EFF ODP	
VOLTAGE:	115/1/60	
UNIT FLA / MCA / MOP:	6.70 AMPS / 7.88 AMPS / 12 AMPS	
GAS TYPE:	NATURAL	
HEATING CAPACITY:	134 MBH (≈ 100.0° F ΔT)	
GAS PRESSURE - MIN.:	7" WC	MAX.: 14" WC
GAS LINE SIZE:	1/2"	
INSURANCE TYPE:	FM/ETL	
MOUNTING LOCATION:	OUTDOOR	
UNIT MATERIAL:	GALVANIZED	
PAINT COLOR:	NONE	
FEATURES & ACCESSORIES		
* Unit Mounting By Others		WEIGHT: -
* OA Filtered Inlet Hood (shipped knocked down) with: - 2" Aluminum Cleanable Filters (MERV 6)		40 LBS.
* Base Unit		285 LBS.
* Motorized Inlet Damper		25 LBS.
* (2) Drop-Out Access Doors		-
* Unit Insulation (1" foil face)		-
* Internal Fan/Motor Vibration Isolators (rubber)		-
* Maxon NP-1-LE Cost Alum. Direct Fired Burner w/ Stainless Steel Mixing Plates		-
* Maxitrol 14 DTC (55°-90°F) w/ TD @ Unit		-
* Direct Spark Ign. w/ Flame Rod Burner Supervision		-
* Non-Fused Disconnect Switch		-
* Mild Weather Stat		-
* EL5 Circuit - No Remote Control Panel, Fan Enable Jumper, & MWS (heat enable)		-
* Main Control Panel		-
* Auto-Profiler System (meets NEMA 1,2,3,3R,3S,4,5 & 12 requirements)		-
-		-
-		-
-		-
-		-
-		-
-		-
-		-
-		-
-		-
-		-
-		-
TOTAL APPROXIMATE WEIGHT:		350 LBS.

REV.	DATE	BY	DESCRIPTION OF REVISION	PROJECT NAME:	MODEL:	TAG:
-	-	-	-	-	T1-HOX	-
-	-	-	-	REF. NO./JOB NO.:	DATE:	SCALE:
-	-	-	-	BMA	06-2020	NONE
-	-	-	-	CERTIFIED BY:	DRAWING NO.:	
-	-	-	-	-	T1-1200-115-1	



DELHI INDUSTRIES SUBMITTAL Date: 06-2020

Project No: _____ Submitted by: _____
 Project Name: _____
 Location: _____
 Engineer: _____
 Architect: _____
 Reference: _____ () ____-____ () ____-____

Equipment Tag

Contractor: _____

Model Information

Series G: DWDI, FC, CENTRIFUGAL

Model: G10-8	Part Number: ---	
CFM: 1200	Shaft Diameter: 0.75 in.	Unit Weight: 23 lbs.
SP: 1.15	Wheel Diameter: 11.1 in	Ship Weight: 25 lbs.
RPM: 1044	Tip Speed: 3041 FPM	
BHP: 0.38	Static Efficiency: 56.5 %	Elevation: 0 ft
	Outlet Velocity: 1447 FPM	Temperature: 70 F

Sound Data

	63	125	250	500	1000	2000	4000	8000	(Hz)	LwA: 80
Sound Power Level @ Frequency, re: 10 ⁻¹² Watts	85	83	80	76	73	72	68	66	(dB)	SONES: 17.5
	Ducted inlet or ducted outlet dBA@10ft. 64					Ducted inlet or ducted outlet dBA@10ft. 64				

Performance Curve

DELHI Model G10-8 x 3/4
 CFM=1200 SP=1.15 BHP=0.38 S. Eff=56.5% RPM=1044

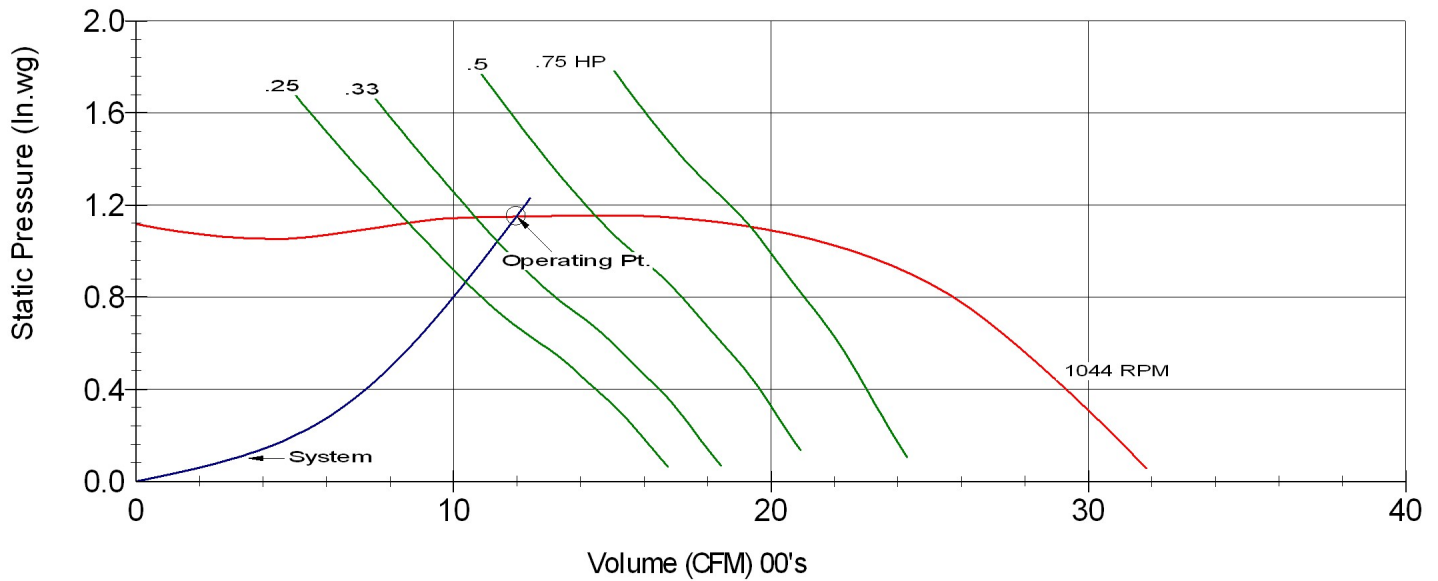

1
2
3
4
5
6
7
8
9
10
11
12
13
14
15
16
17
18
19
20
21
22
23
24
25
26
27
28
29
30
31
32
33
34
35
36
37
38
39
40
41
42
43
44
45
46
47
48
49
50
51
52
53
54
55
56
57
58
59
60
61
62
63
64
65
66
67
68
69
70
71
72
73
74
75
76
77
78
79
80
81
82
83
84
85
86
87
88
89
90
91
92
93
94
95
96
97
98
99
100
101
102
103
104
105
106
107
108
109
110
111
112
113
114
115
116

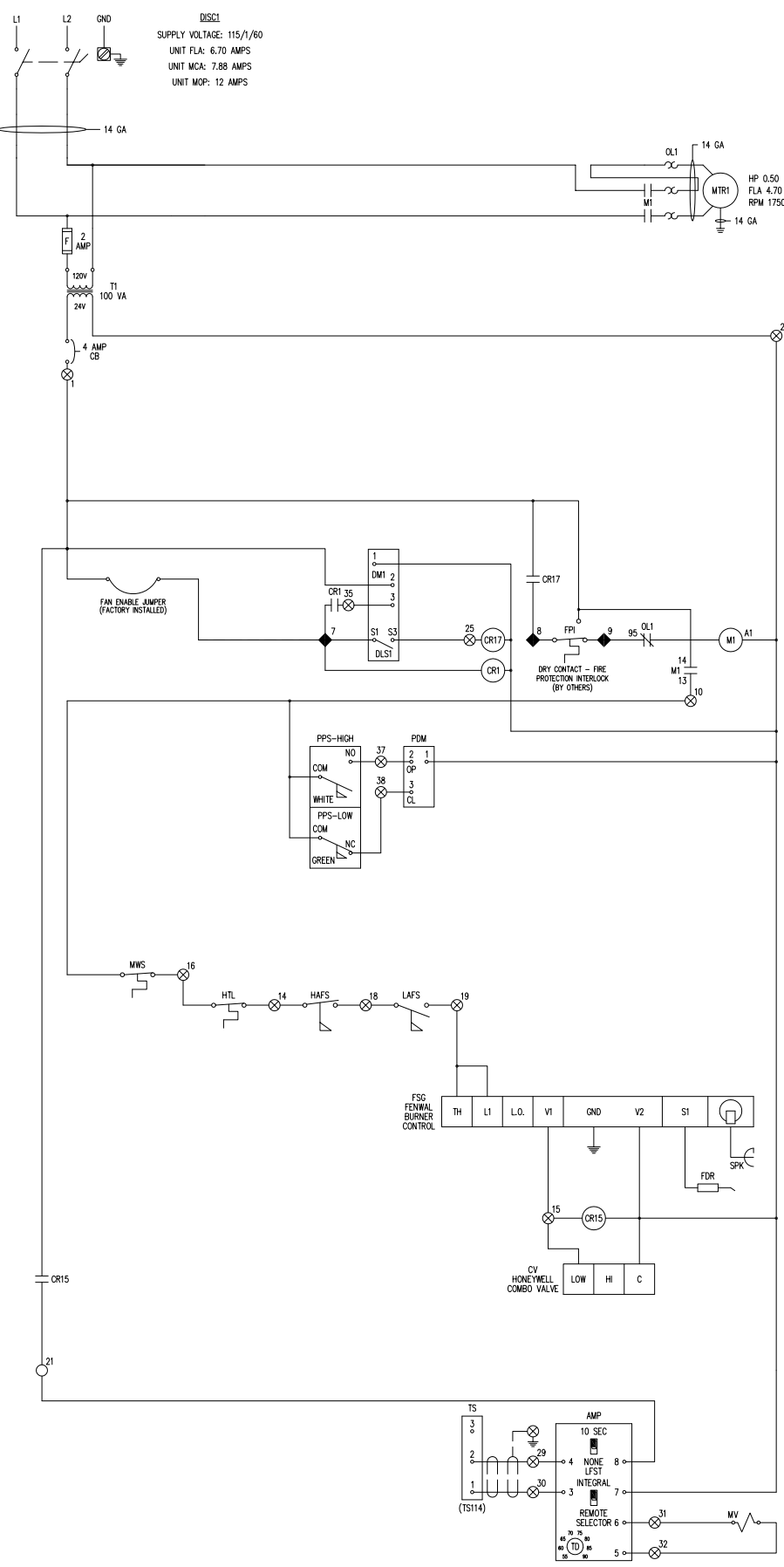

- DISCONNECT SWITCH
- SUPPLY FAN MOTOR OVERLOAD RELAY
- SUPPLY FAN MOTOR
- CONTROL TRANSFORMER
- CIRCUIT BREAKER
- INLET DAMPER MOTOR
- FAN ENABLE JUMPER
- DAMPER LIMIT SWITCH
- SUPPLY FAN MOTOR CONTACTOR
- DAMPER RELAY
- UNIT ENABLE RELAY
- PROFILE PRESSURE SWITCH (HIGH)
- PROFILE DAMPER MOTOR
- PROFILE PRESSURE SWITCH (LOW)
- MILD WEATHER STAT
- HIGH TEMPERATURE LIMIT SWITCH
- HIGH AIR FLOW SWITCH
- LOW AIR FLOW SWITCH
- FLAME SAFEGUARD CONTROL
- SPARK IGNITOR
- FLAME DETECTION ROD
- BURNER ON RELAY
- DIRECT IGNITION COMB. GAS VALVE
- TEMPERATURE CONTROL AMPLIFIER
- DISCHARGE TEMPERATURE SENSOR
- MODULATING GAS VALVE
- TEMPERATURE DIAL

PROPRIETARY

PLEASE NOTE

ALL FIELD WIRING SHALL BE THWN, THHN OR MTW WIRE TYPE (OR SHIELDED CABLE WHERE NOTED ON SCHEMATIC) RATED FOR 75° C AND LABELED OR IDENTIFIED AT EACH END FOR EACH CONNECTION BEING MADE. WIRING SHALL BE INSTALLED PER NEC AND LOCAL CODE REQUIREMENTS

ALL CONTROL WIRING SHALL BE AS FOLLOWS:

GAUGE	MAX DISTANCE
18	50'
16	75'
14	150'
12	250'

* DO NOT RUN LINE VOLTAGE WIRES WITH CONTROL WIRES *

LEGEND

SYMBOL	DEFINED AS
	(GND) EARTH GROUND GALV, ZINC, MAGNESIUM ROD
	WIRE NUMBERS
	TERMINALS IN CONTROL PANEL
	TERMINALS IN REMOTE PANEL
	REMOTE PANEL WIRING
	FIELD WIRING BETWEEN TERMINALS IN REMOTE PANEL & TERMINALS IN UNIT CONTROL PANEL
	SHIELDED CABLE
	FIELD INSTALLED & WIRED
	FIELD CONNECTION

UNIT SET POINTS

DEVICE	RECOMMENDED SETTING:
HAFS / LAFS	0.60" / 0.20" WC
HTL	130° F
MWS	65° F
PPS-HIGH	CLOSES ABOVE 0.35" WC
PPS-LOW	CLOSES BELOW 0.25" WC
-	-
-	-
-	-
-	-
-	-

REVISIONS

REV.	DATE	REV. BY
-	-	-
-	-	-
-	-	-
-	-	-
-	-	-
-	-	-



PROJECT INFORMATION

PROJECT NAME:	
MODEL NO.:	T1-HOX
SERIAL NO.:	-
TAG:	-
DATE:	06-2020
SCALE:	NONE
DRAWN BY:	BMA
DRAWING NO.:	T1-1200-115-1

115-1-60

208/230-1-60

208/230/460/575-3-60

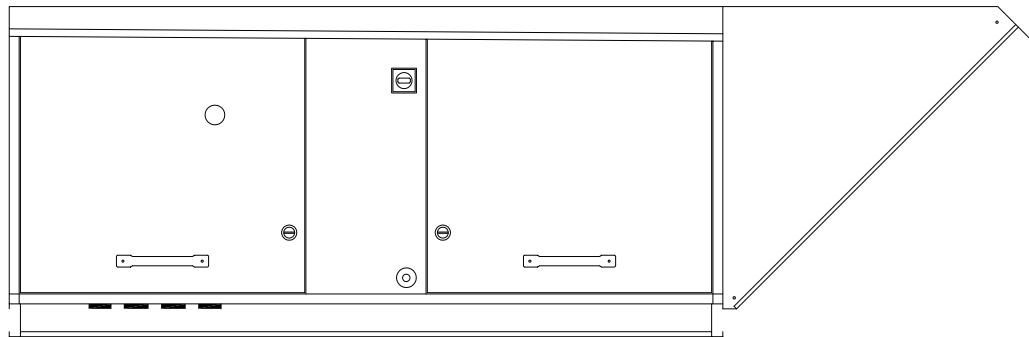
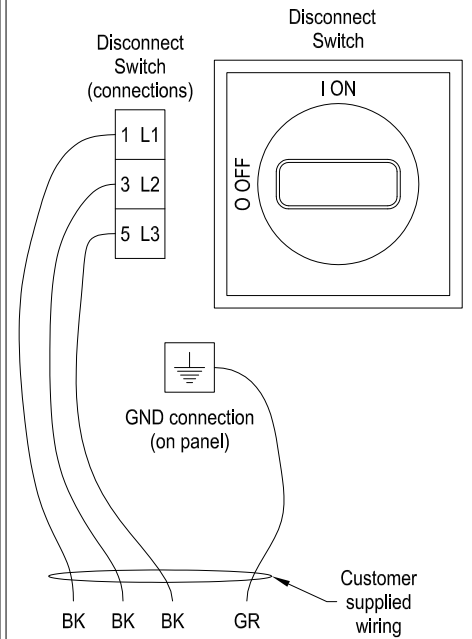
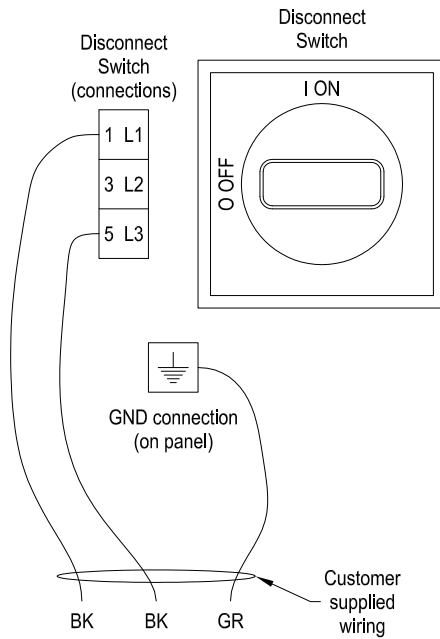
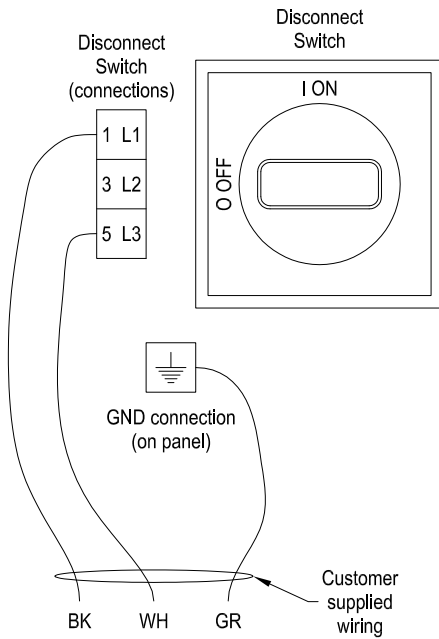

Power Connection (see above for details) Control Connection (see below for details)

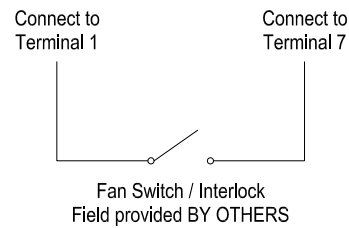

PROJECT NAME:	NAKS T1-T5 DIRECT FIRED MUA INSTALLATION WIRING		
REF. NO./JOB NO.:	-	MODEL: T1-T5	TAG: -
DRAWN BY:	-	DATE: 06-2020	SCALE: NONE
CERTIFIED BY:		DRAWING NO.:	T1-T5_INSTALL