

## Gas-Fired Tempered Make-Up Air Unit

Model:

TK2DD-3PH-FF

3-Phase, 208V, 2.00 HP, Direct Drive, Premium (E-Plus) Eff. Motor with Motorized Damper and 20" Blower. MAX 3500 CFM's

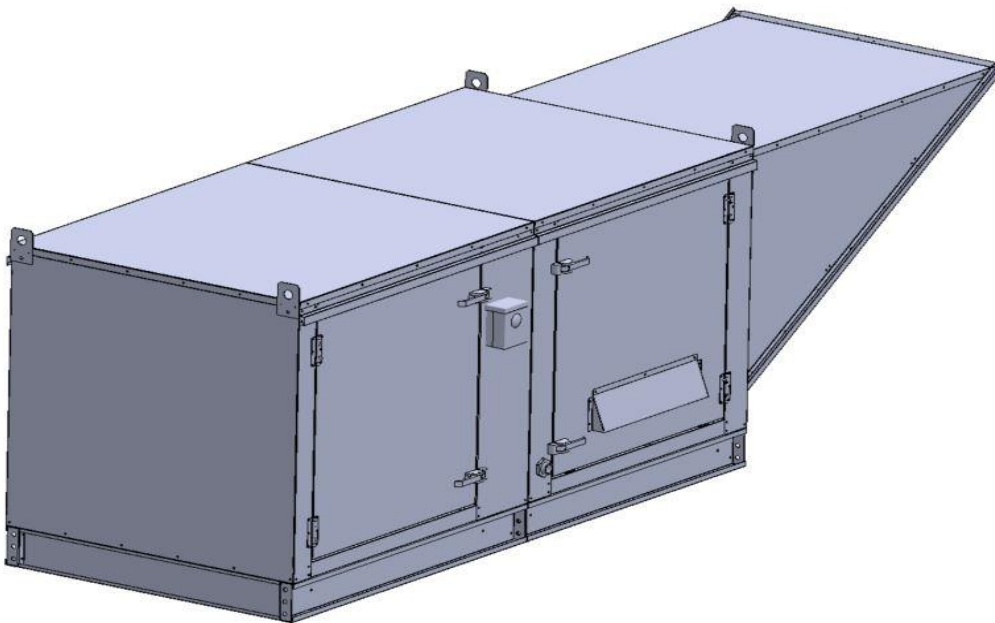

TK2-500-20D Direct Fired Direct Drive (813 lbs.)



Direct Gas Fired Heated Make Up Air Unit with 20" Direct Drive Fan

**Supply Motor:**

Model DTP0024, 2.000 HP, 3 Phase, 208 V, 60Hz, 6.1 FLA, ODP, Premium (E-Plus3) Eff.

**Burner:**

Min Output BTU: 18,000 BTU/Hr  
Max Output BTU: 550,000 BTU/Hr  
Size: 12" long  
Gas Type: Natural

**Supply Performance:**

Volume Range: 2000-3500 cfm  
RPM: 1375  
TS: 7199 ft/min  
SP: 0.578" w.g.  
0.500" Ext. + 0.051" Int. + 0.027" Opt.  
BHP: 1.439

**Heating Schedule:**

Altitude: 0'  
Winter Entering Air Dry Bulb Temp: 0°F  
Temp Rise: 100°F  
Output BTU: 378000  
Input BTU: 410870  
BTUs BASED OFF STANDARD AIR DENSITY

**Supply Installation Information:**

Gas Inlet Pressure: 7 in. w.c. - 14 in. w.c.  
Insurance: No Insurance Requirement (ANSI)  
Unit Main Input: 8.8 Amps MCA, 15 Amps MOP, 208 V, 14 AWG Wire Min.  
Supply Unit Voltage: 3 phs 208 V 60Hz

**Construction Features**

Housing constructed of heavy duty G90 galvanized steel • Vibration isolation • Ball bearing motors • Heavy duty, pre-lubricated bearings rated for 200,000 hours of operation • Service doors on both sides • Horizontal & down discharge • Large intake area ensures low pressure drop across unit • Spring loaded profile plates automatically adjust for any airflow - no manual setting required! • Weatherproof safety disconnect switch • Modular design provides design flexibility • Fully insulated casing

**Blower:**

20 Inch Mixed Flow Plenum Fan for size 2 MOD. Hub specified to match motor shaft.

**Temp Control:**

RTC Solutions • 40-90°F Discharge Temp Control • Field Wired On/Off Start Command

**Intake:**

Sloped Filtered Intake for Size #2 Modular Heater. 26.813" Wide X 53.625" Long X 31.313" High. Includes 2" MV EZ Kleen Metal Mesh Filters.

**Filters:**

3x MV EZ Kleen Metal Mesh Filter. 20"x 25"x 2" Used for heater and supply fan intakes. (3416)

**Selected Options:**

- Low Fire Start. Allows the burner circuit to energize when the modulation control is in a low fire position.
- Gas Pressure Gauge, 0-35", 2.5" Diameter, 1/4" Thread Size
- Gas Pressure Gauge, -5 to +15 Inches Wc., 2.5" Diameter, 1/4" Thread Size
- Motorized Back Draft Damper 22.75" X 24" for Size 2 Standard & Modular Heater Units w/Extended Shaft, Standard Galvanized Construction, 3/4" Rear Flange, Low Leakage, LF120S Actuator Included
- VAV (Variable-Air-Volume) Wiring Package for Commercial Fans. Manual Speed Control Variable Frequency Drive Included
- Supply Variable Frequency Drive - 2 HP Max., 200/240 V, Single or Three Phase Input, 7.0 A Max., NEMA 1 Enclosure, (Default is Shipped Loose for Field Installation) PART NEEDS PROGRAMMING
- Profile Plate Configuration for size 2 Direct Fired Unit for low cfm applications.
- VFD factory mounted and wired on unit control panel.

**TK2-500-20D DIRECT FIRED HEATER**

1. DIRECT GAS FIRED HEATED MAKE UP AIR UNIT WITH 20" DIRECT DRIVE FAN
2. INTAKE HOOD WITH EZ FILTERS
3. DOWN DISCHARGE - AIR FLOW RIGHT -> LEFT
4. LOW FIRE START. ALLOWS THE BURNER CIRCUIT TO ENERGIZE WHEN THE MODULATION CONTROL IS IN A LOW FIRE POSITION.
5. GAS PRESSURE GAUGE, 0-35", 2.5" DIAMETER, 1/4" THREAD SIZE
6. GAS PRESSURE GAUGE, -5 TO +15 INCHES WC, 2.5" DIAMETER, 1/4" THREAD SIZE
7. MOTORIZED BACK DRAFT DAMPER 22.75" X 24" FOR SIZE 2 STANDARD & MODULAR HEATER UNITS W/EXTENDED SHAFT, STANDARD GALVANIZED CONSTRUCTION, 3/4" REAR FLANGE, LOW LEAKAGE, LF120S ACTUATOR INCLUDED
8. VAV (VARIABLE-AIR-VOLUME) WIRING PACKAGE FOR COMMERCIAL FANS.
9. VFD FACTORY MOUNTED AND WIRED ON UNIT CONTROL PANEL.

NOTE: SUPPLY DUCT MUST BE INSTALLED TO MEET SMACNA STANDARDS. A MINIMUM STRAIGHT DUCT LENGTH MUST BE MAINTAINED DOWNSTREAM OF UNIT DISCHARGE UNLESS OTHERWISE SPECIFIED. DO NOT RELY ON UNIT TO SUPPORT DUCT IN ANY WAY. FAILURE TO PROPERLY SIZE DUCTWORK MAY CAUSE SYSTEM EFFECTS AND REDUCE PERFORMANCE OF THE EQUIPMENT.

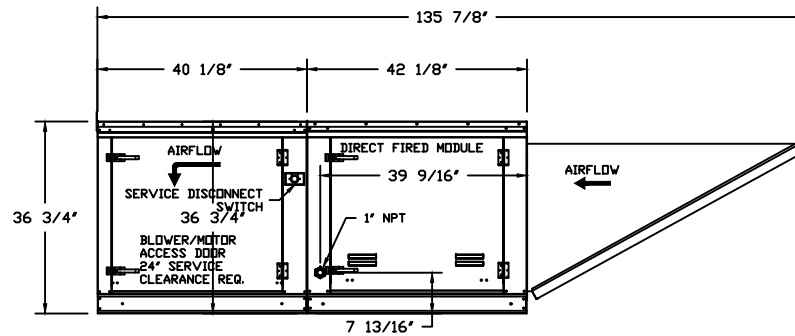
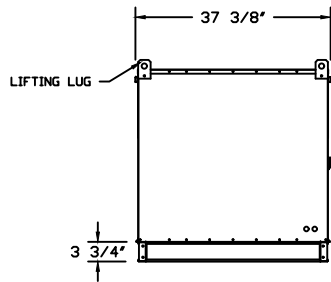
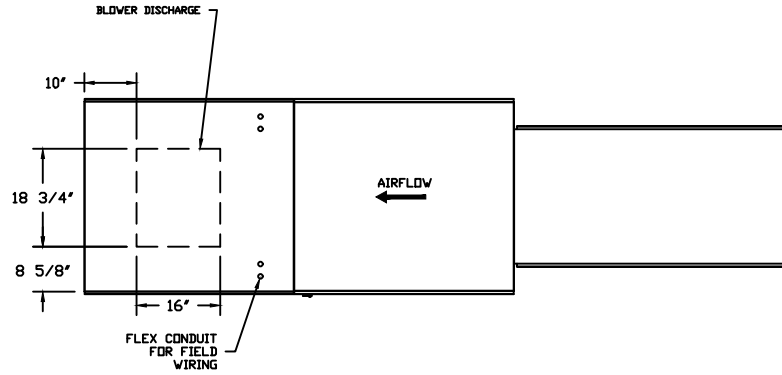

JOB	
LOCATION	
DATE	JOB #
DWG #	DRAWN BY
REV.	SCALE 1/4" = 1'-0"

(3500 2HP/3PH-208V) - HEATER PERFORMANCE CURVES.

3500 CFM, 0.578 SP @ 1375 RPM and 1.439 BHP at 0 feet and 100 deg F  
 \* Please note that these curves were adjusted for job specific temperature and altitude.

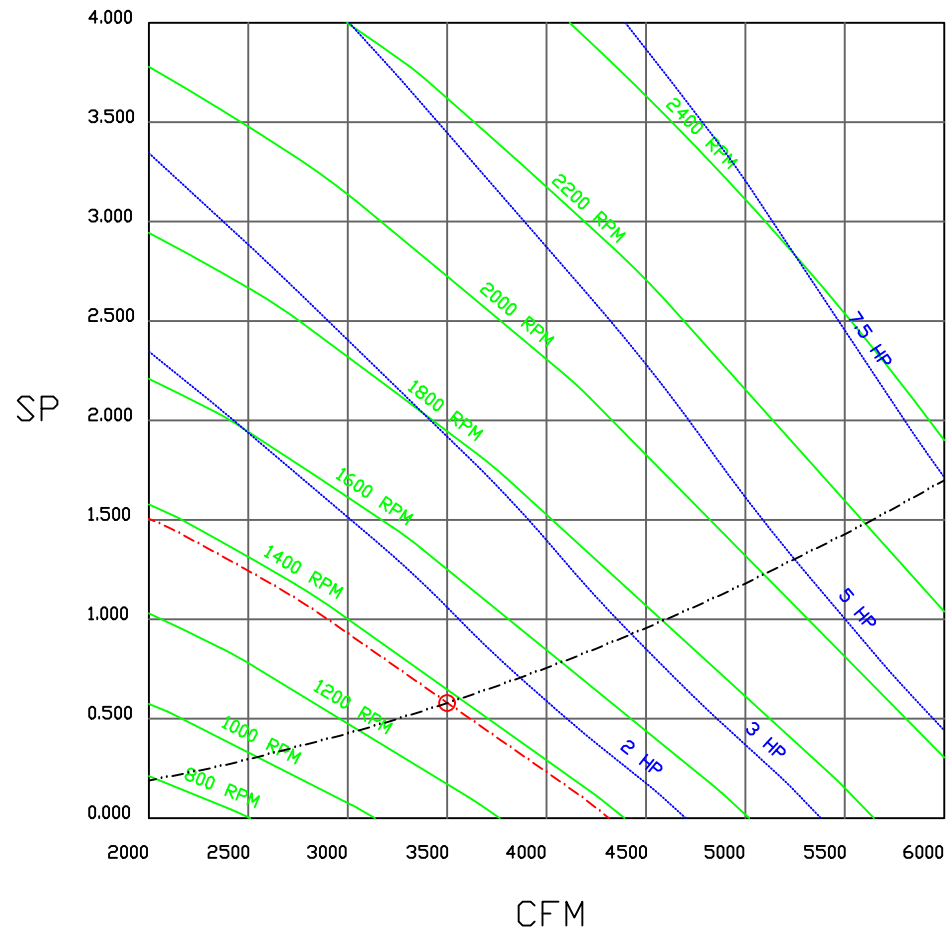

JOB	
LOCATION	
DATE	JOB #
DWG #	DRAWN BY
REV.	SCALE 3/8" = 1'-0"

VFD Wiring

JOB NAKS Direct Fired Direct Drive MUA

DRAWING NUMBER

SHIP DATE

MODEL TK 1-5 Series Direct Drive

SMV SERIES VARIABLE FREQUENCY DRIVE

Installed Options  
Manual Control

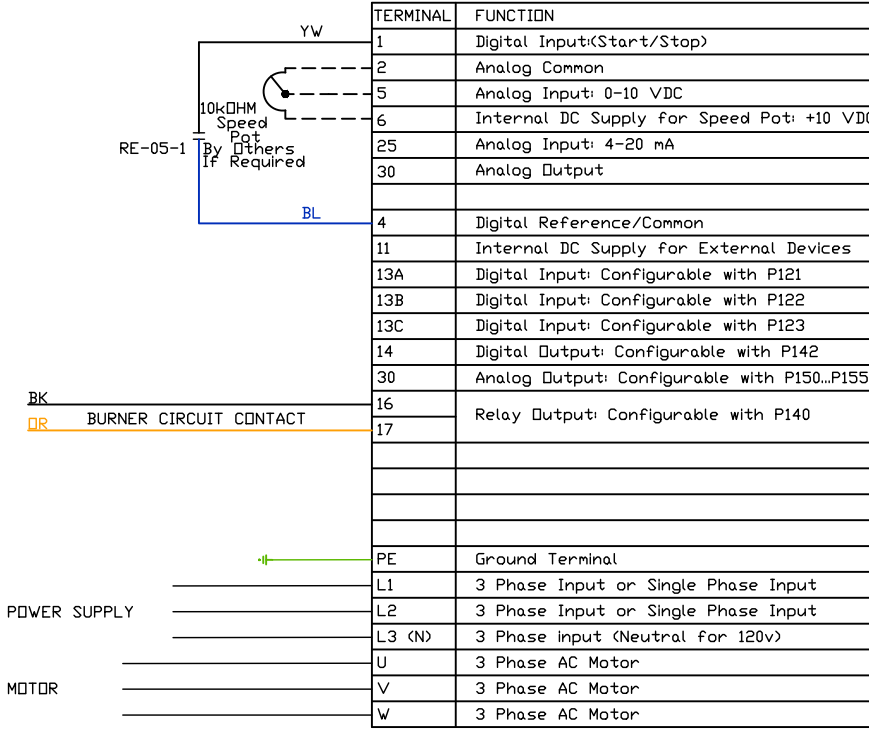

TERMINAL	FUNCTION
1	Digital Input(Start/Stop)
2	Analog Common
5	Analog Input: 0-10 VDC
6	Internal DC Supply for Speed Pot: +10 VDC
25	Analog Input: 4-20 mA
30	Analog Output
4	Digital Reference/Common
11	Internal DC Supply for External Devices
13A	Digital Input: Configurable with P121
13B	Digital Input: Configurable with P122
13C	Digital Input: Configurable with P123
14	Digital Output: Configurable with P142
30	Analog Output: Configurable with P150...P155
16	Relay Output: Configurable with P140
17	Relay Output: Configurable with P140
PE	Ground Terminal
L1	3 Phase Input or Single Phase Input
L2	3 Phase Input or Single Phase Input
L3 (N)	3 Phase input (Neutral for 120v)
U	3 Phase AC Motor
V	3 Phase AC Motor
W	3 Phase AC Motor

Component Identification

RE-05 VFD Start relay [2]

SUPPLY DRIVE PARAMETER SETTINGS\*

All external control wires to motor speed control should be 16-20 AWG shielded multiconductor cables and must not be run in the same conduit or raceway with any high power wiring. Ground Shielded Cable at the drive chassis ONLY.

EPH PROGRAM: VAV\_MAKUSE LG\_HP EPH IF >= 15HP)  
 P100 (Start Source) = 01 (Terminal Strip)  
 P102 = ##Minimum Frequency (Hz)  
 P103 = ##Maximum Frequency (Hz)  
 (P103 is based on max wheel RPM)  
 P110 (Start Method) = 03 (Auto Re-start)  
 P140 (Form A (NO) Relay) = 01 (Run)  
 P144 (Relay Inversion) = 00 (None)  
 P166 (Carrier Frequency) = 00 (4 kHz)  
 P171 (Current Limit) = 150 (% of Max I)

PG. 11 OF THE DRIVE MANUAL DESCRIBES THE PROPER INSTALLATION PROCEDURE

Adjust manually on all drives  
 P107 = 00 (If 120 or 208 VAC)  
 or 01 (If 230, 480 or 575 VAC)  
 P108 = Motor FLA x 100 / Drive Output Rating  
 P165 (Base Voltage) = Set to Motor Voltage  
 (Preset@230V) P165 FOR STANDARD DRIVE ONLY  
 P167 (Base Frequency) = Calculated Per Fan  
 FOR KB PCU ONLY: P300 = 0

PG. 19 OF THE DRIVE MANUAL DESCRIBES THE PROGRAMMING PROCEDURE OF THE DRIVE

PG. 23 OF THE DRIVE MANUAL DESCRIBES THE PARAMETER SETTINGS OF THE DRIVE

\*NOTE: THE DEFAULT PASSWORD FROM THE FACTORY REQUIRED TO PROGRAM THE DRIVE IS '225'.

When Speed POT is Required the Following Parameters Must be Set:  
 P101 (Reference Source) = 01 (0-10 VDC)  
 P160 (Speed @ 0 VDC Signal) = Min Frequency  
 P161 (Speed @ 10 VDC Signal) = Max Frequency

IT MAY BE REQUIRED TO FULLY POWER DOWN THE DRIVE AND TURN BACK ON IN ORDER TO INITIATE NEW PARAMETER SETTINGS.

##Min. and Max. Frequency Settings override all other Preset speeds/Parameters.

MOTOR INFO  
 SUPPLY 2HP-208V-3P-6.1FLA  
 VFD PART: ESV152N02YXB

ELECTRICAL INFORMATION  
 MOTOR/CTRL CIRCUIT MCA: 8.8A  
 MOTOR/CTRL CIRCUIT MDP: 15A

NOTES

----- DENOTES FIELD WIRING  
 \_\_\_\_\_ DENOTES INTERNAL WIRING

WIRE COLOR

BK - BLACK YW - YELLOW  
 BL - BLUE GR - GREEN  
 BR - BRDN GY - GRAY  
 OR - ORANGE PR - PURPLE  
 RD - RED PK - PINK  
 WH - WHITE

GENERAL NOTES

1  
2  
3  
4  
5  
6  
7  
8  
9  
10  
11  
12  
13  
14  
15  
16  
17  
18  
19  
20  
21  
22  
23

# Direct Fired Heater Wiring

JOB NAKS Direct Fired Direct Drive MUA

DRAWING NUMBER

SHIP DATE

MODEL TK 1-5 Series Direct Drive

ATTENTION ELECTRICIAN!  
 DROP FDR DISCONNECT CONNECTION  
 IS FACTORY SUPPLIED  
 CONNECT POWER TO THE DROP

Installed Options  
 Field Wired Single Switch Control  
 Motorized Back Draft Damper

Discharge Temp. Control

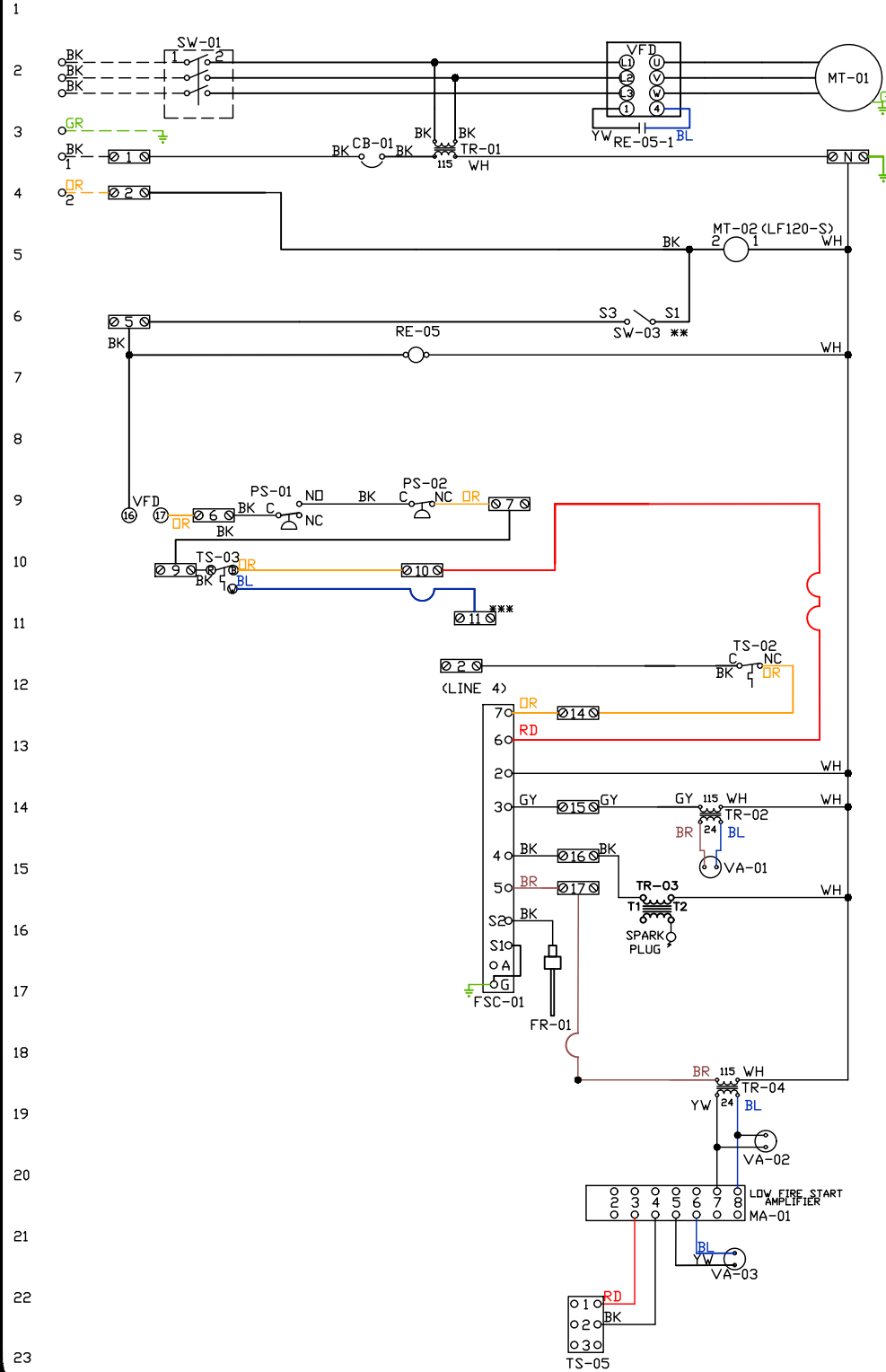

Label	Component Identification Description	Location
CB-01	Circuit breaker (2amp)	[3]
FR-01	Flame rod	[16]
FSC-01	Fireeye FSC	[11-14]
MA-01	Modulating amplifier	[19]
MT-01	Supply motor	[2]
MT-02	Damper motor	[5]
PS-01	Low Air-Flow Switch	[9]
PS-02	High Air-Flow Switch	[9]
RE-05	VFD Start Relay	[3][6]

SW-01	Main disconnect switch	[2]
SW-03	Damper end limit switch	[4]
TR-01	Power transformer(200va)	[12]
TR-02	Power transformer(20va)	[12]
TR-03	Ignition transformer	[14]
TR-04	Power transformer(20va)	[17]
TS-02	High temp limit switch	[10]
TS-03	Intake Air Sensor	[10]
TS-05	Discharge Air Sensor	[21]
VA-01	Pilot gas valve	[13]
VA-02	Main gas valve	[18]
VA-03	Modulating gas valve	[20]

**MOTOR INFO**  
 SUPPLY 2HP-208V-3P-6.1FLA  
 VFD PART: ESV152N02YXB

**ELECTRICAL INFORMATION**  
 MOTOR/CTRL CIRCUIT MCB: 8.8A  
 MOTOR/CTRL CIRCUIT MDP: 15A

**NOTES**  
 - - - - DENOTES FIELD WIRING  
 \_\_\_\_\_ DENOTES INTERNAL WIRING

\*\* TERMINALS S4 AND S6 USED ON NF & AF SERIES ACTUATORS  
 \*\*\* TERMINAL 11 PROVIDES COOLING CONNECTION

WIRE COLOR	SOCKET STYLE
BK-BLACK	NO 4 1 3
BL-BLUE	NC 2 1
BR - BROWN	COM 8 7
DK - DRANGE	COM 6 5
FR - PURPLE	
GY - GRAY	
RD - RED	
WH - WHITE	
PK - PINK	

# Installation Wiring

JOB *NAKS Direct Fired MUA*

DRAWING NUMBER

SHIP DATE

MODEL **TK 1-5 Series**

Installed Options

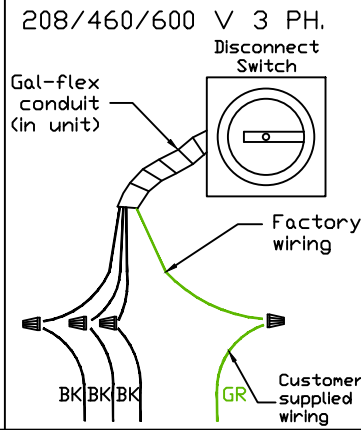
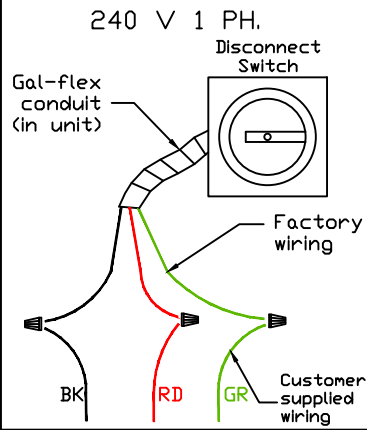
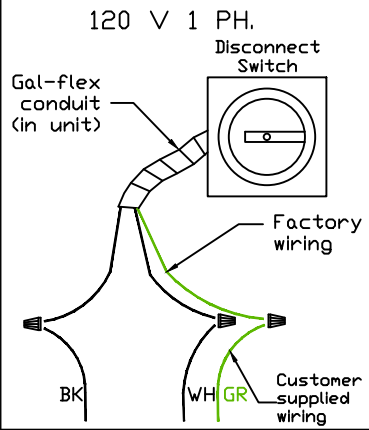

Field Wired On/Off Switch

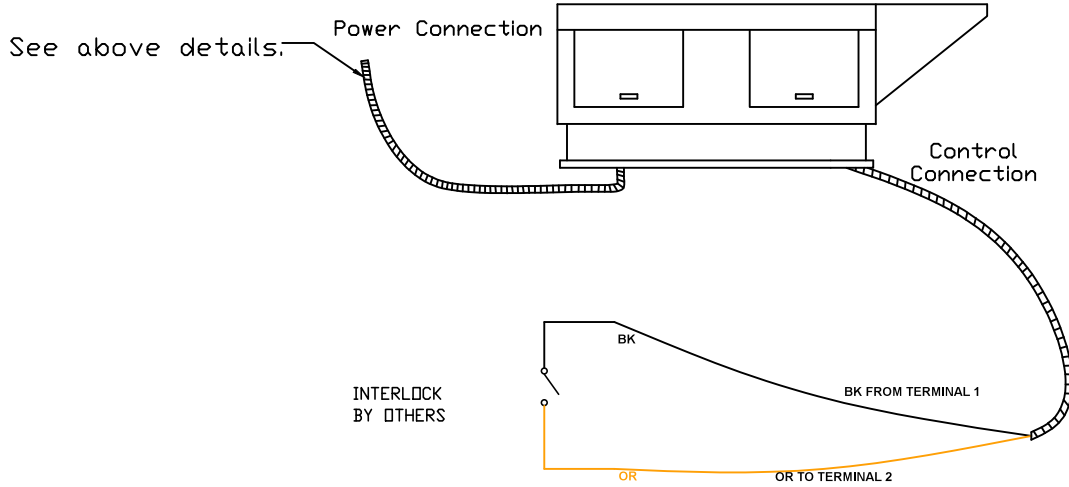

NOTES

- WIRE COLOR**
- BK - BLACK
  - BL - BLUE
  - BR - BROWN
  - OR - ORANGE
  - RD - RED
  - WH - WHITE
  - YW - YELLOW
  - GR - GREEN
  - GY - GRAY
  - PR - PURPLE
  - PK - PINK