

Gas-Fired Tempered Make-Up Air Unit

Model:

TK3DD-1PH-FF

1-Phase, 230V, 7.50 HP, Direct Drive, Premium (E-Plus) Eff. Motor with Motorized Damper and 24" Blower. MAX 6200 CFM's.



TK3-750-24D Direct Fired Direct Drive (1031 lbs.)



Direct Gas Fired Heated Make Up Air Unit with 24" Direct Drive Fan and 18" Burner.

Supply Motor:

Model DTP7/54, 7.500 HP, 3 Phase, 230 V, 60Hz, 19.1 FLA, ODP, Premium (E-Plus3) Eff.

Burner:

Min Output BTU: 27,500 BTU/Hr
Max Output BTU: 825,000 BTU/Hr
Size: 18" long
Gas Type: Natural

Supply Performance:

Volume Range: 3500-6200 cfm
RPM: 1466
TS: 9211 ft/min
SP: 0.639" w.g.
0.500" Ext. + 0.109" Int. + 0.030" Opt.
BHP: 6.021

Heating Schedule:

Altitude: 0'
Winter Entering Air Dry Bulb Temp: 0°F
Temp Rise: 100°F
Output BTU: 669600
Input BTU: 727826
BTUs BASED OFF STANDARD AIR DENSITY

Supply Installation Information:

Gas Inlet Pressure: 7 in. w.c. - 14 in. w.c.
Insurance: No Insurance Requirement (ANSI)
Unit Main Input: 61.1 Amps MCA, 100 Amps MOP, 230 V, 6 AWG Wire Min.
Supply Unit Voltage: 1 phs 230 V 60Hz

Construction Features

Housing constructed of heavy duty G90 galvanized steel • Vibration isolation • Ball bearing motors • Heavy duty, pre-lubricated bearings rated for 200,000 hours of operation • Service doors on both sides • Horizontal & down discharge • Large intake area ensures low pressure drop across unit • Spring loaded profile plates automatically adjust for any airflow - no manual setting required! • Weatherproof safety disconnect switch • Modular design provides design flexibility • Fully insulated casing

Blower:

24 Inch Mixed Flow Plenum Fan for size 3 MOD. Hub specified to match motor shaft.

Temp Control:

RTC Solutions • 40-90°F Discharge Temp Control • Field Wired On/Off Start Command

Intake:

Sloped Filtered Intake for Size #3 Modular Heater. 37.25" Wide X 51.625" Long X 35.188" High. Includes 2" MV EZ Kleen Metal Mesh Filter.

Filters:

6x MV EZ Kleen Metal Mesh Filter. 16"x 20"x 2" Used for heater and supply fan intakes. (3412)

Selected Options:

- Motorized Back Draft Damper 30" X 30" for Size 3 Standard & Modular Heater Units w/Extended Shaft, Standard Galvanized Construction, 3/4" Rear Flange, Low Leakage, NFBUP-S Actuator Included
- Low Fire Start. Allows the burner circuit to energize when the modulation control is in a low fire position.
- Gas Pressure Gauge, 0-35", 2.5" Diameter, 1/4" Thread Size
- Gas Pressure Gauge, -5 to +15 Inches Wc., 2.5" Diameter, 1/4" Thread Size
- VAV (Variable-Air-Volume) Wiring Package for Commercial Fans. Manual Speed Control Variable Frequency Drive Included
- Supply Variable Frequency Drive - 15 HP Max., 200/240 V, Three Phase, 42.0 A Max., NEMA 1 Enclosure, (Default is Shipped Loose for Field Installation) PART NEEDS PROGRAMMING

TK3-750-24D DIRECT FIRED HEATER

1. DIRECT GAS FIRED HEATED MAKE UP AIR UNIT WITH 24" DIRECT DRIVE FAN AND 18" BURNER.
 2. INTAKE HOOD WITH EZ FILTERS
 3. DOWN DISCHARGE - AIR FLOW RIGHT -> LEFT
 4. MOTORIZED BACK DRAFT DAMPER 30" X 30" FOR SIZE 3 STANDARD & MODULAR HEATER UNITS W/EXTENDED SHAFT, STANDARD GALVANIZED CONSTRUCTION, 3/4" REAR FLANGE, LOW LEAKAGE, NF-BUP-S ACTUATOR INCLUDED
 5. LOW FIRE START. ALLOWS THE BURNER CIRCUIT TO ENERGIZE WHEN THE MODULATION CONTROL IS IN A LOW FIRE POSITION.
 6. GAS PRESSURE GAUGE, 0-35", 2.5" DIAMETER, 1/4" THREAD SIZE
 7. GAS PRESSURE GAUGE, -5 TO +15 INCHES WC., 2.5" DIAMETER, 1/4" THREAD SIZE
 8. VAV (VARIABLE-AIR-VOLUME) WIRING PACKAGE FOR COMMERCIAL FANS.
- MANUAL SPEED CONTROL VARIABLE FREQUENCY DRIVE INCLUDED

NOTE: SUPPLY DUCT MUST BE INSTALLED TO MEET SMACNA STANDARDS. A MINIMUM STRAIGHT DUCT LENGTH MUST BE MAINTAINED DOWNSTREAM OF UNIT DISCHARGE UNLESS OTHERWISE SPECIFIED. DO NOT RELY ON UNIT TO SUPPORT DUCT IN ANY WAY. FAILURE TO PROPERLY SIZE DUCTWORK MAY CAUSE SYSTEM EFFECTS AND REDUCE PERFORMANCE OF THE EQUIPMENT.

SUPPLY SIDE HEATER INFORMATION:

WINTER TEMPERATURE = 0°F. TEMP. RISE = 100°F.
 BTUs CALCULATED OFF STANDARD AIR DENSITY
 OUTPUT BTUs AT ALTITUDE OF 0.0 ft. = 669600
 INPUT BTUs AT ALTITUDE OF 0.0 ft. = 727826

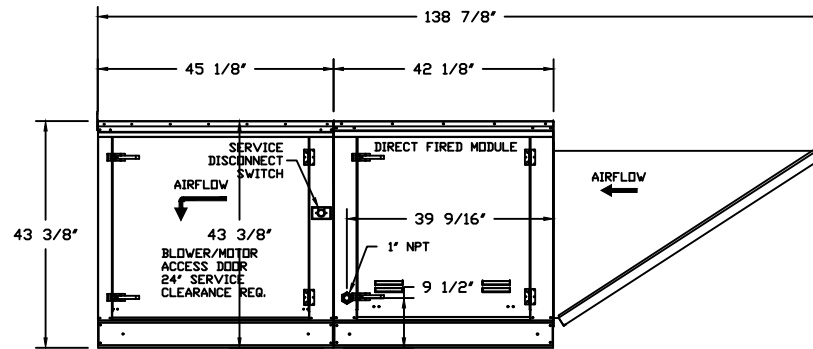
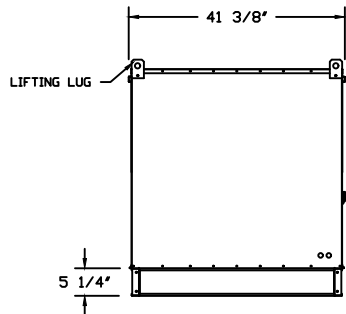
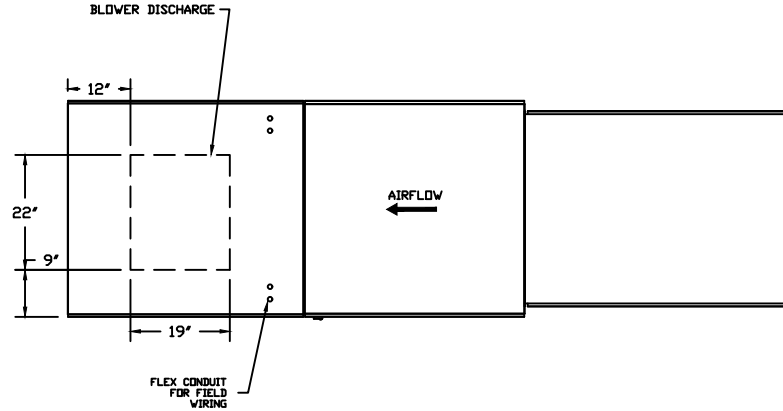

JOB	
LOCATION	
DATE	JOB #
DWG #	DRAWN BY
REV.	SCALE 1/4" = 1'-0"

(6200 7.5HP/1PH-230V) - HEATER PERFORMANCE CURVES.

6200 CFM, 0.639 SP @ 1466 RPM and 6.021 BHP at 0 feet and 100 deg F
 * Please note that these curves were adjusted for job specific temperature and altitude.

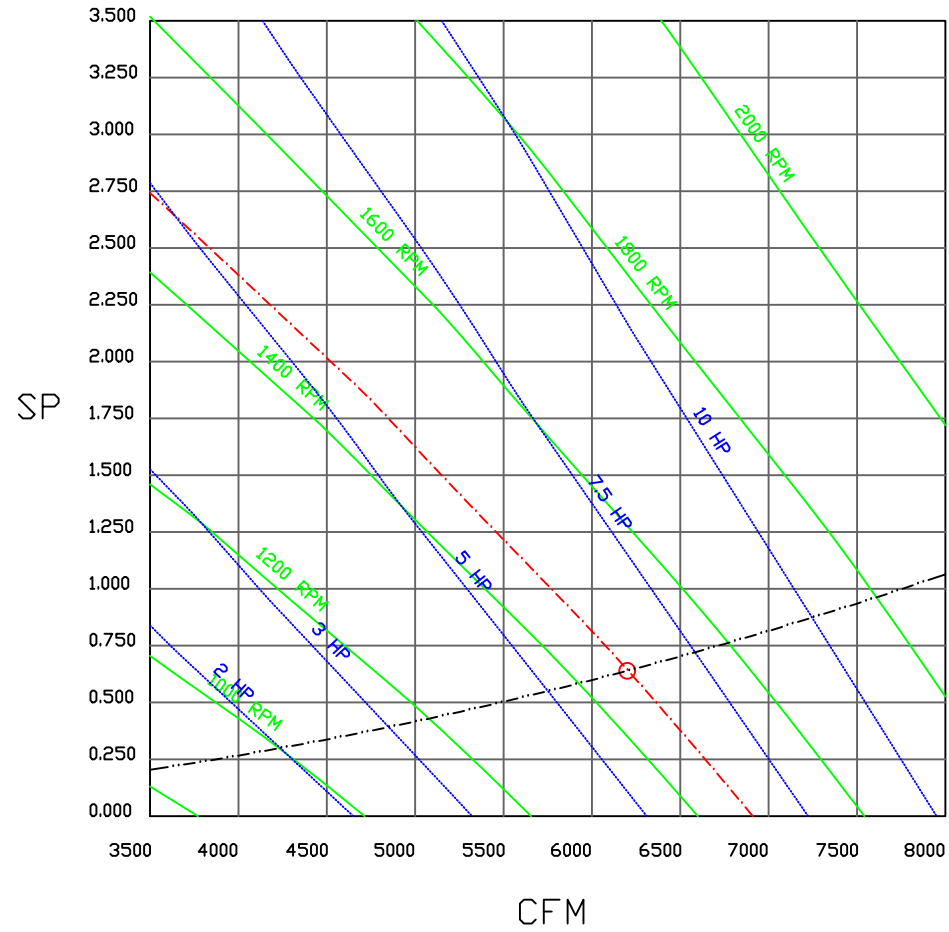

JOB	
LOCATION	
DATE	JOB #
DWG #	DRAWN BY
REV.	SCALE 3/8" = 1'-0"

VFD Wiring

JOB NAKS Direct Fired Direct Drive MUA

DRAWING NUMBER

SHIP DATE

MODEL TK 1-5 Series Direct Drive

SMV SERIES VARIABLE FREQUENCY DRIVE

Installed Options
Manual Control

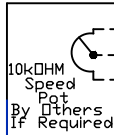

TERMINAL	FUNCTION
1	Digital Input(Start/Stop)
2	Analog Common
5	Analog Input: 0-10 VDC
6	Internal DC Supply for Speed Pot: +10 VDC
25	Analog Input: 4-20 mA
30	Analog Output
4	Digital Reference/Common
11	Internal DC Supply for External Devices
13A	Digital Input: Configurable with P121
13B	Digital Input: Configurable with P122
13C	Digital Input: Configurable with P123
14	Digital Output: Configurable with P142
30	Analog Output: Configurable with P150...P155
16	Relay Output: Configurable with P140
17	Relay Output: Configurable with P140
PE	Ground Terminal
L1	3 Phase Input or Single Phase Input
L2	3 Phase Input or Single Phase Input
L3 (N)	3 Phase input (Neutral for 120v)
U	3 Phase AC Motor
V	3 Phase AC Motor
W	3 Phase AC Motor

NOT USED FOR EXHAUST FANS
OR NON-HEATED SUPPLY FANS
BURNER CIRCUIT CONTACT

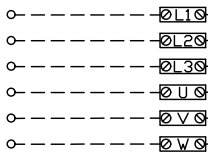

TERMINAL BLOCKS
LOCATED IN HEATER UNIT
(IF SINGLE PHASE INPUT, UNIT MAY
NOT CONTAIN ALL TERMINAL BLOCKS)

EXHAUST FANS AND NON-HEATED
UNITS DO NOT HAVE TERMINALS

All external control wires to motor speed control should be 16-20 AWG shielded multiconductor cables and must not be run in the same conduit or raceway with any high power wiring. Ground Shielded Cable at the drive chassis ONLY.

PG. 11 OF THE DRIVE MANUAL DESCRIBES THE PROPER
INSTALLATION PROCEDURE

PG. 19 OF THE DRIVE MANUAL DESCRIBES THE PROGRAMMING
PROCEDURE OF THE DRIVE

PG. 23 OF THE DRIVE MANUAL DESCRIBES THE PARAMETER
SETTINGS OF THE DRIVE

NOTE: THE DEFAULT PASSWORD FROM THE FACTORY REQUIRED
TO PROGRAM THE DRIVE IS '225'.

SUPPLY DRIVE PARAMETER SETTINGS*

EPH PROGRAM: VAV_MANKUSE LG_HP EPH IF >= 15HP)
P100 (Start Source) = 01 (Terminal Strip)
P102 = ##Minimum Frequency (Hz)
P103 = ##Maximum Frequency (Hz)
(P103 is based on max wheel RPM)
P110 (Start Method) = 03 (Auto Re-start)
P140 (Form A (NO) Relay) = 01 (Run)
P144 (Relay Inversion) = 00 (None)
P166 (Carrier Frequency) = 00 (4 kHz)
P171 (Current Limit) = 150 (% of Max I)

Adjust manually on all drives
P107 = 00 (If 120 or 208 VAC)
or 01 (If 230, 480 or 575 VAC)
P108 = Motor FLA x 100 / Drive Output Rating
P165 (Base Voltage) = Set to Motor Voltage
(Preset@230V) P165 FOR STANDARD DRIVE ONLY
P167 (Base Frequency) = Calculated Per Fan
FOR KB PCU ONLY: P300 = 0

When Speed POT is Required the Following
Parameters Must be Set:
P101 (Reference Source) = 01 (0-10 VDC)
P160 (Speed @ 0 VDC Signal) = Min Frequency
P161 (Speed @ 10 VDC Signal) = Max Frequency

IT MAY BE REQUIRED TO FULLY POWER DOWN THE DRIVE
AND TURN BACK ON IN ORDER TO INITIATE NEW
PARAMETER SETTINGS.

##Min. and Max. Frequency Settings override all
other Preset speeds/Parameters.

GENERAL NOTES

Component Identification

MOTOR INFO
SUPPLY 7.5HP-230V-3P-19.1FLA
CONTACTOR: 100-C60D10
VFD PART: ESV113N021XB571

ELECTRICAL INFORMATION
MOTOR/CTRL CIRCUIT MCA: 611A
MOTOR/CTRL CIRCUIT MDP: 100A

NOTES
- - - - DENOTES FIELD WIRING
_____ DENOTES INTERNAL WIRING

WIRE COLOR
BK - BLACK YW - YELLOW
BL - BLUE GR - GREEN
BR - BRDN GY - GRAY
OR - ORANGE PR - PURPLE
RD - RED PK - PINK
WH - WHITE

Direct Fired Heater Wiring

JOB NAKS Direct Fired Direct Drive MUA

DRAWING NUMBER

SHIP DATE

MODEL TK 1-5 Series Direct Drive

ATTENTION ELECTRICIAN!
 DROP FDR DISCONNECT CONNECTION
 IS FACTORY SUPPLIED
 CONNECT POWER TO THE DROP

Installed Options
 Field Wired Single Switch Control
 Motorized Back Draft Damper

Discharge Temp. Control

VFD

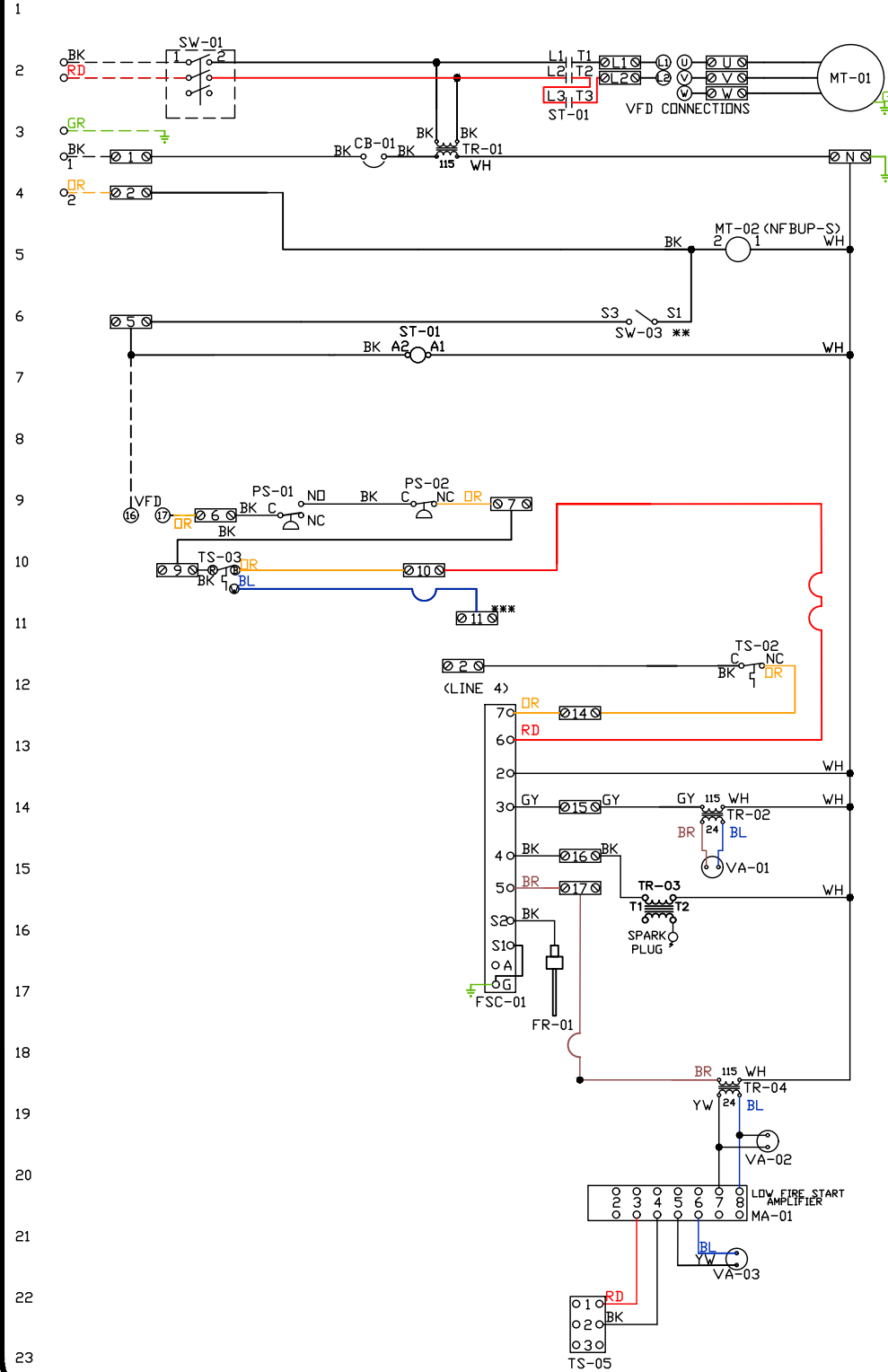

Label	Component Identification Description	Location
CB-01	Circuit breaker (2amp)	[3]
FR-01	Flame rod	[16]
FSC-01	Fireeye FSC	[11-14]
MA-01	Modulating amplifier	[19]
MT-01	Supply motor	[2]
MT-02	Damper motor	[5]
PS-01	Low AirFlow Switch	[9]
PS-02	High AirFlow Switch	[9]

ST-01	Supply motor contactor [2][7][9]
SW-01	Main disconnect switch [2]
SW-03	Damper end limit switch [4]
TR-01	Power transformer(200va)
TR-02	Power transformer(20va)
TR-03	Ignition transformer [14]
TR-04	Power transformer(20va)[17]
TS-02	High temp limit switch [10]
TS-03	Intake Air Sensor [10]
TS-05	Discharge Air Sensor [21]

MOTOR INFO
 SUPPLY 7.5HP-230V-3P-19.1FLA
 CONTACTOR: 100-C60D10
 VFD PART: ESV113N02TXB571

ELECTRICAL INFORMATION
 MOTOR/CTRL CIRCUIT MCB: 61A
 MOTOR/CTRL CIRCUIT MDP: 100A

NOTES
 - - - - DENOTES FIELD WIRING
 _____ DENOTES INTERNAL WIRING

** TERMINALS S4 AND S6 USED ON NF & AF SERIES ACTUATORS
 *** TERMINAL 11 PROVIDES COOLING CONNECTION

WIRE COLOR	SOCKET STYLE "COLD" RELAY
BK-BLACK	NO [4] [3]
BL-BLUE	NC [2] [1]
BR - BROWN	COM [8] [7]
GY - GRAY	COM [6] [5]
OR - ORANGE	
PR - PURPLE	
RD - RED	
WH - WHITE	
PK - PINK	

Installation Wiring

JOB NAKS Direct Fired MUA

DRAWING NUMBER

SHIP DATE

MODEL TK 1-5 Series

Installed Options



Field Wired On/Off Switch

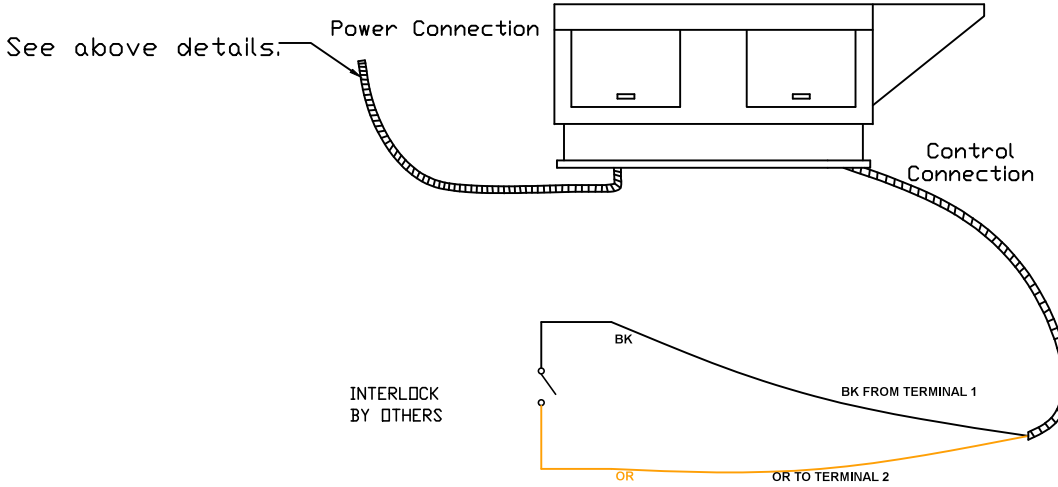

NOTES

WIRE COLOR

- | | |
|-------------|-------------|
| BK - BLACK | YW - YELLOW |
| BL - BLUE | GR - GREEN |
| BR - BROWN | GY - GRAY |
| OR - ORANGE | PR - PURPLE |
| RD - RED | PK - PINK |
| WH - WHITE | |