

**The truth is, your walk-in floors will take a beating.**

When choosing your walk-in floor consider practicality, traffic volume and type, durability, ease of cleaning, as well as an overall design that will deliver lasting performance. Our expert team of account managers will advise you that floors are first to feel the wear and tear of the busy kitchen. This NAKS floor selection guide will help you choose a floor that best fits your needs. And, you can rest assured you are getting a structurally sound floor because our *panel lamination process* is in compliance with ICC-ES code guidelines. NSF, UL listed.

**NAKS Offers 4 Floor Finishes and 4 Floor Options:**

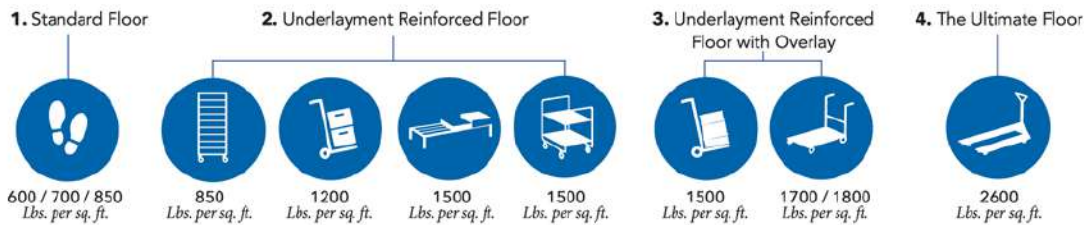

**.050 SMOOTH ALUMINUM - INTEGRAL**

NAKS' standard integral floor finish with a 1/2"-radius NSF cove along the interior walk-in perimeter. Our standard floor is rated to support **600 pounds** per-square-foot (PSF) of uniformly distributed load. This is a great choice for **foot traffic applications**.



**22 GAUGE SMOOTH STAINLESS STEEL - INTEGRAL**

Optional integral floor finish with 1/2"-radius NSF cove along the interior walk-in perimeter. This floor offers greater resistance to wear and improves load bearing strength compared to standard alternative. Rated to support **700 PSF** of uniformly distributed load. Stainless steel is a sanitary metal finish that is easier to clean and maintain.

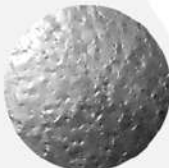

**22 GAUGE TEXTURED STAINLESS STEEL - INTEGRAL - Customer Preferred**

A stronger alternative to a smooth stainless steel floor finish. Also integral, it comes with 1/2"-radius NSF cove along the interior walk-in perimeter. The textured stainless steel finish offers greater resistance to scratches and conceals daily wear and tear. With this floor finish heavy carts are easier to push with its low textured profile. It also provides greater foot traffic traction and is easy to clean. Rated to support **850 PSF** of uniformly distributed load.



**.090 ALUMINUM DIAMOND TREAD PLATE - OVERLAY SHEETS**

We recommend aluminum diamond tread plate floor overlay for heavy duty applications. This floor significantly increases resistance to wear. We ship pre-cut overlay sheets that are field installed on an existing floor, overlapping floor panel joints. Overlay sheets increase load bearing capacity by **500 PSF** of uniformly distributed load.

**FLOOR SELECTION GUIDE**

## 1. Standard Floor

Suitable for everyday foot traffic applications and a great choice for small compartment walk-ins. Our standard .050 smooth aluminum finish flooring is rated at 600 pounds per-square-foot (PSF) of uniformly distributed load. Optional floor finish alternatives include smooth and textured stainless steel.

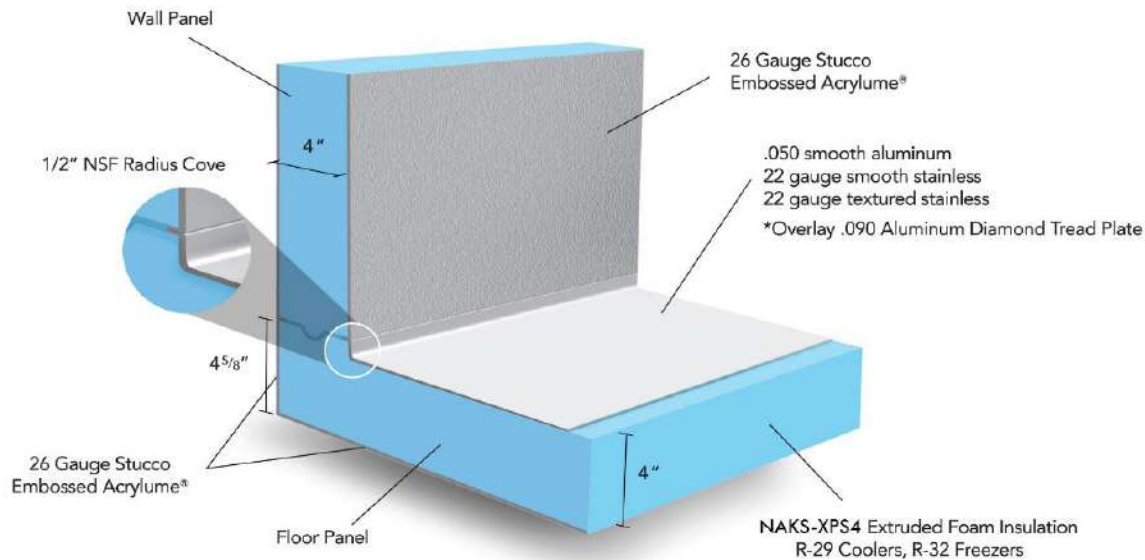

Figure 1. Side cut  
Standard floor view



FOOT TRAFFIC

## 2. Underlayment Reinforced Floor - Customer Preferred

Suitable for Pan Rolling Racks, Hand Trucks, Dunnage Racks and Log Carts. With standard finish rated at 1200 PSF; 1300 PSF with smooth stainless steel; or 1500 PSF of uniformly distributed load with textured stainless steel.

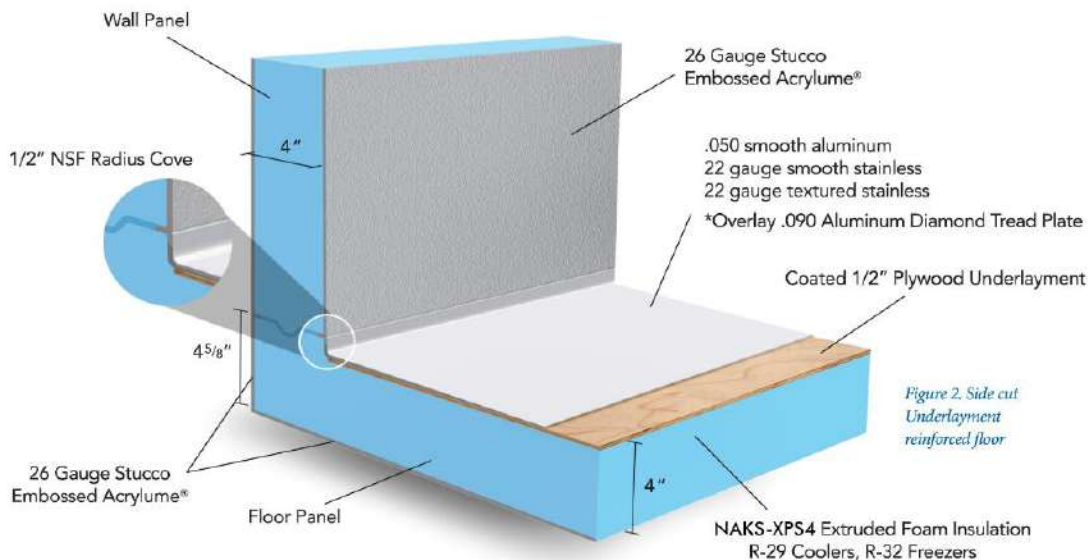

Figure 2. Side cut  
Underlayment  
reinforced floor



PAN ROLLING  
RACKS



HAND TRUCKS



DUNNAGE RACKS



LOG CARTS



DOLLIE CARTS

### 3. Underlayment Reinforced Floor with Overlay

This underlayment reinforced floor with overlay is designed to withstand years of heavy duty service. Offers more even spread of weight across entire floor. This floor is suitable for Hand Trucks, Dunnage Racks, Beer Keg Carts, Log Carts and Dollie Carts. Standard finish rated at 1700 PSF; and 1800 PSF of evenly distributed load with smooth stainless steel.

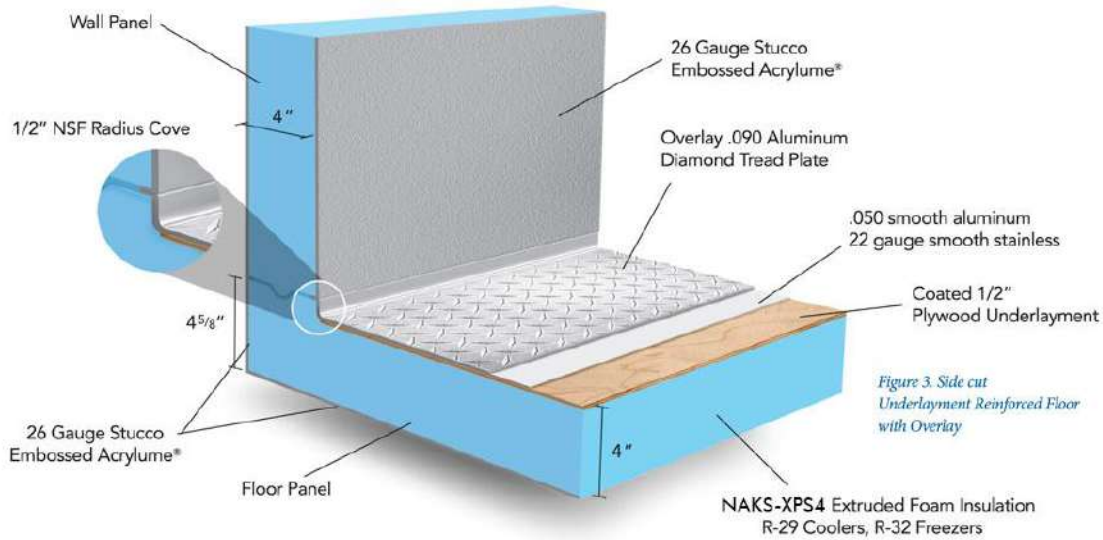

-  HAND TRUCKS
-  DUNNAGE RACKS
-  BEER KEG CARTS
-  LOG CARTS
-  DOLLIE CARTS

### 4. The Ultimate Floor

The NAKS ultimate reinforced floor is suitable for Hand Pallet Jack applications. It is rated at 2600 PSF of evenly distributed load with textured stainless steel finish.

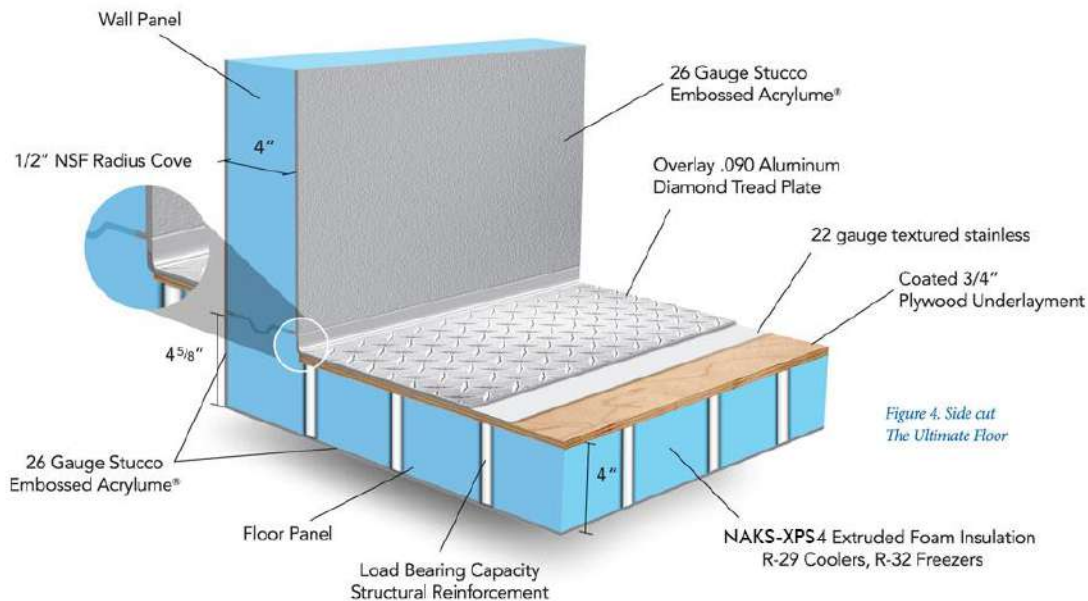

-  DOLLIE CARTS
-  HAND PALLET JACK

## Floor Construction Features

All floor panels consist of:

- Durable, corrosion-resistant Acrylume® exterior metal skins
- Integral floor panels with 1/2" radius cove to facilitate cleaning
- 4" XPS4 Extruded Foam Insulation
- No hard-nose low insulation framing
- Assembly with corrosion resistant cam-action locking devices
- Tongue and groove with same XPS4 insulation
- NSF approved compression gaskets applied to tongue side of all panels
- Access to locking devices via interior of panels
- PVC press-fit caps provided to seal 3/8" diameter hex-wrench ports, after assembly is completed.

## Maintenance Guidelines

We recommend cleaning walk-in floors with a damp mop. Use of excess or pooling water will void warranty.

## Popular Ramp Options

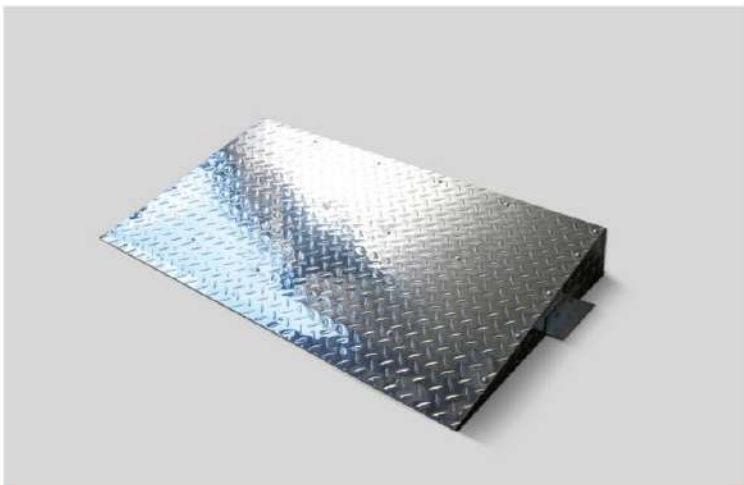

Exterior Ramp



Interior Ramp

Standard sizes: 24" deep for 36", 30" and 26" wide door opening.